



**SEW**  
**EURODRIVE**

# Assembly and Operating Instructions



**Gear unit series R..7, F..7, K..7, K..9, S..7, SPIROPLAN® W**



## Table of contents

<b>1</b>	<b>General information</b> .....	<b>5</b>
1.1	About this documentation .....	5
1.2	Structure of the safety notes .....	5
1.3	Rights to claim under limited warranty .....	6
1.4	Exclusion of liability .....	7
1.5	Product names and trademarks .....	7
1.6	Copyright notice .....	7
<b>2</b>	<b>Safety notes</b> .....	<b>8</b>
2.1	Preliminary information .....	8
2.2	General information .....	8
2.3	Target group .....	9
2.4	Designated use .....	9
2.5	Other applicable documentation .....	9
2.6	Transportation/storage .....	9
2.7	Installation .....	10
2.8	Startup/operation .....	10
2.9	Inspection/maintenance .....	10
<b>3</b>	<b>Gear unit structure</b> .....	<b>11</b>
3.1	Basic structure of helical gear units .....	11
3.2	Basic structure of parallel-shaft helical gear units .....	12
3.3	Basic structure of helical-bevel gear units K..19/K..29 .....	13
3.4	Basic structure of helical-bevel gear units K..39/K..49 .....	14
3.5	Basic structure of helical-bevel gear units K..37 – K..187 .....	15
3.6	Basic structure of helical-worm gear units .....	16
3.7	Basic structure of SPIROPLAN® gear units W..10 – W..30 .....	17
3.8	Basic structure of SPIROPLAN® gear units W..37 – W..47 .....	18
3.9	Nameplate/type designation .....	19
<b>4</b>	<b>Mechanical installation</b> .....	<b>22</b>
4.1	Prerequisites for installation .....	22
4.2	Installing the gear unit .....	24
4.3	Gear unit with solid shaft .....	31
4.4	Torque arms for shaft-mounted gear units .....	33
4.5	Shaft-mounted gear units with keyway or splined hollow shaft .....	38
4.6	Shaft-mounted gear unit with shrink disk .....	44
4.7	Shaft-mounted gear units with TorqLOC® .....	47
4.8	Mounting the cover .....	59
4.9	Coupling of AM adapters .....	61
4.10	AQ. adapter coupling .....	65
4.11	EWH adapters .....	68
4.12	AD Input shaft assembly .....	70
4.13	Accessory equipment .....	74
<b>5</b>	<b>Startup</b> .....	<b>83</b>
5.1	Checking the oil level .....	83

5.2	Pseudo-leakage at shaft seals .....	84
5.3	Helical-worm gear units and SPIROPLAN® W gear units .....	85
5.4	Helical/parallel shaft helical/helical-bevel gear units .....	85
5.5	Gear units with backstop .....	86
5.6	Components made of elastomers with fluorocarbon rubber .....	86
<b>6</b>	<b>Inspection/maintenance.....</b>	<b>88</b>
6.1	General information .....	88
6.2	Wearing parts .....	90
6.3	Inspection/maintenance intervals .....	92
6.4	Lubricant change intervals .....	93
6.5	Maintenance of AL/AM/AQ./EWH adapter .....	93
6.6	AD input shaft assembly maintenance .....	94
6.7	Inspection/maintenance for the gear unit .....	95
<b>7</b>	<b>Mounting positions .....</b>	<b>110</b>
7.1	Designation of the mounting positions .....	110
7.2	Churning losses .....	111
7.3	Mounting position MX .....	111
7.4	Universal mounting position M0 .....	111
7.5	Mounting positions of SPIROPLAN® gear units .....	112
7.6	Mounting position sheets .....	112
<b>8</b>	<b>Technical data.....</b>	<b>146</b>
8.1	Extended storage .....	146
8.2	Lubricants .....	148
<b>9</b>	<b>Malfunctions .....</b>	<b>157</b>
9.1	Gear units .....	158
9.2	Adapters AM/AQ./AL/EWH .....	159
9.3	AD input shaft assembly .....	159
9.4	Customer service .....	160
9.5	Waste disposal .....	160
<b>10</b>	<b>Address list.....</b>	<b>161</b>
	<b>Index .....</b>	<b>172</b>

# 1 General information

## 1.1 About this documentation

This documentation is an integral part of the product. The documentation is intended for all employees who perform assembly, installation, startup, and service work on the product.

Make sure this documentation is accessible and legible. Ensure that persons responsible for the machinery and its operation as well as persons who work on the device independently have read through the documentation carefully and understood it. If you are unclear about any of the information in this documentation or require further information, contact SEW-EURODRIVE.

## 1.2 Structure of the safety notes

### 1.2.1 Meaning of signal words

The following table shows the grading and meaning of the signal words for safety notes.

Signal word	Meaning	Consequences if disregarded
<b>▲ DANGER</b>	Imminent hazard	Severe or fatal injuries.
<b>▲ WARNING</b>	Possible dangerous situation	Severe or fatal injuries.
<b>▲ CAUTION</b>	Possible dangerous situation	Minor injuries
<b>NOTICE</b>	Possible damage to property	Damage to the drive system or its environment.
<b>INFORMATION</b>	Useful information or tip: Simplifies handling of the drive system.	

### 1.2.2 Structure of section-related safety notes

Section-related safety notes do not apply to a specific action but to several actions pertaining to one subject. The hazard symbols used either indicate a general hazard or a specific hazard.

This is the formal structure of a safety note for a specific section:



#### SIGNAL WORD







Type and source of hazard.

Possible consequence(s) if disregarded.

- Measure(s) to prevent the hazard.

### Meaning of the hazard symbols

The hazard symbols in the safety notes have the following meaning:

Hazard symbol	Meaning
	General hazard
	Warning of dangerous electrical voltage
	Warning of hot surfaces
	Warning of risk of crushing
	Warning of suspended load
	Warning of automatic restart

#### 1.2.3 Structure of embedded safety notes

Embedded safety notes are directly integrated into the instructions just before the description of the dangerous action.

This is the formal structure of an embedded safety note:

- **▲ SIGNAL WORD** Type and source of hazard.  
Possible consequence(s) if disregarded.
  - Measure(s) to prevent the hazard.

### 1.3 Rights to claim under limited warranty

Read the information in this documentation. This is essential for fault-free operation and fulfillment of any rights to claim under limited warranty. Read the documentation before you start working with the unit!

#### **1.4 Exclusion of liability**

Read the information in this documentation, otherwise safe operation is impossible. You must comply with the information contained in this documentation to achieve the specified product characteristics and performance features. SEW-EURODRIVE assumes no liability for injury to persons or damage to equipment or property resulting from non-observance of these operating instructions. In such cases, SEW-EURODRIVE assumes no liability for defects.

#### **1.5 Product names and trademarks**

The brands and product names in this documentation are trademarks or registered trademarks of their respective titleholders.

#### **1.6 Copyright notice**

© 2015 SEW-EURODRIVE. All rights reserved.

Copyright law prohibits the unauthorized reproduction, modification, distribution, and use of this document, in whole or in part.

## 2 Safety notes

### 2.1 Preliminary information

The following basic safety notes must be read carefully to prevent injury to persons and damage to property. The user must ensure that the basic safety notes are read and observed. Ensure that persons responsible for the machinery and its operation as well as persons who work on the unit independently have read through the documentation carefully and understood it. If you are unclear about any of the information in this documentation, or if you require further information, please contact SEW-EURODRIVE.

The following safety notes are primarily concerned with the use of the unit described in these operating instructions. If you use other components from SEW-EURODRIVE, also refer to the safety notes for these particular components in the corresponding documentation.

Also observe the additional safety notes provided in the individual chapters of this document.

### 2.2 General information



#### ▲ WARNING

Danger of fatal injury or risk of injury during the operation of motors or gearmotors caused by live, bare (in the event of open connectors/terminal boxes) and movable or rotating parts.

Danger of fatal injury.

- All work related to transport, storage, installation, assembly, connection, startup, maintenance and repair may only be carried out by qualified personnel.
- For transport, storage, installation, assembly, connection, startup, maintenance and repair note the following documents:
  - Warning and safety signs on the motor/gearmotor
  - All the project planning documents, startup instructions and wiring diagrams related to the drive
  - System-specific regulations and requirements
  - National/regional regulations governing safety and the prevention of accidents.
- Never install damaged products.
- Never operate or energize the unit without the necessary protection covers or housing.
- Use the unit only for its intended purpose.
- Make sure installation and operation are correct.



#### INFORMATION

Submit any complaint to the shipping company immediately in the event of transportation damage.



## 2.3 Target group

Any mechanical work may only be performed by adequately qualified personnel. Qualified personnel in the context of this documentation are persons familiar with the design, mechanical installation, troubleshooting and servicing of the product, who possess the following qualifications:

- Training in mechanical engineering, e.g. as a mechanic or mechatronics technician (final examinations must have been passed).
- They are familiar with these operating instructions.

Any electronic work may only be performed by adequately skilled person (electrically). Skilled person (electrically) in the context of this documentation are persons familiar with electrical installation, startup, troubleshooting and servicing of the product, who possess the following qualifications:

- Training in electrical engineering, e.g. as an electrician, electronics or mechatronics technician (final examinations must have been passed).
- They are familiar with these operating instructions.

All work in the areas of transportation, storage, operation and waste disposal must be carried out by persons who are trained appropriately.

All qualified personnel must wear appropriate protective clothing.

## 2.4 Designated use

The gear unit series R..7, F..7, K..7, K..9, S..7, SPIROPLAN® W is intended for use in industrial systems.

The gear units may only be used according to the specifications in the technical documentation from SEW-EURODRIVE as well as the specifications on the nameplate. They fulfill the applicable standards and regulations.

When installed in machines, startup (i.e. start of designated operation) is prohibited until it is determined that the machine complies with the local laws and directives. In the individual area of application, you must especially observe the Machinery Directive 2006/42/EC as well as the EMC Directive 2004/108/EC. The EMC test specifications EN 61000-4-2, EN 61000-4-3, EN 61000-4-4, EN 61000-4-6 and EN 61000-6-2 must be taken into account during startup.

Using these products in potentially explosive atmospheres is prohibited, unless specifically designated otherwise.

## 2.5 Other applicable documentation

Observe the corresponding documentation for all connected devices.

## 2.6 Transportation/storage

Inspect the shipment for damage as soon as you receive the delivery. Inform the shipping company immediately about any damage. If necessary postpone motor startup.

Tighten attached lifting eyes securely. The lifting eyes are designed to carry only the weight of the motor/gear unit/gearmotor. Do not apply any additional loads.

The installed lifting eyebolts are in accordance with DIN 580. Observe the loads and regulations specified there. If the motor/gear unit/gearmotor has 2 lifting eye lugs or lifting eyebolts, then you should also use both lifting eye lugs for attaching transport ropes. In this case, the tension force vector of the slings must not exceed a 45° angle in accordance with DIN 580.

Use suitable, sufficiently rated handling equipment, that can be used for further transport.

In case the motor/gear unit/gearmotor is not installed immediately store it dry, free of dust and not outdoors. Do not store the motor/gearmotor on the fan guard. The motor/gear unit/gearmotor can be stored for up to 9 months without requiring any special measures before startup.

## 2.7 Installation



### NOTICE

Danger due to static overdetermination if gear units with foot (e.g. KA19/29B, KA127/157B or FA127/157B) are mounted both via the torque arm and via the foot plate.

Risk of injuries and damage to property.

- Especially with the KA.9B/T design, it is not permitted to use the foot plates and the torque arm at the same time.
- Attach the KA 9B/T design only via the torque arm.
- Attach the K.9 or KA.9B design only via the foot plate.
- If you want to use foot plates and torque arms for mounting, contact SEW-EURODRIVE.

Observe the notes in chapter "Mechanical installation (→ 22)".

## 2.8 Startup/operation

Check the oil level before startup as described in chapter Inspection/Maintenance (→ 88).

Check for proper direction of rotation in **decoupled** state. Listen out for unusual grinding noises as the shaft rotates.

Secure the key for the test run without output elements. Do not deactivate monitoring and protection devices even for a test run.

Switch off the gearmotor if in doubt whenever changes occur in relation to normal operation (e.g. increased temperature, unusual noise, vibration). Determine the cause. It may be necessary to contact SEW-EURODRIVE.

## 2.9 Inspection/maintenance

Observe the notes in chapter "Inspection/Maintenance"!

**3 Gear unit structure**

**INFORMATION**



The following figures are block diagrams. Their purpose is only to make it easier to assign components to the spare parts lists. Discrepancies may occur depending on the gear unit size and version.

**3.1 Basic structure of helical gear units**

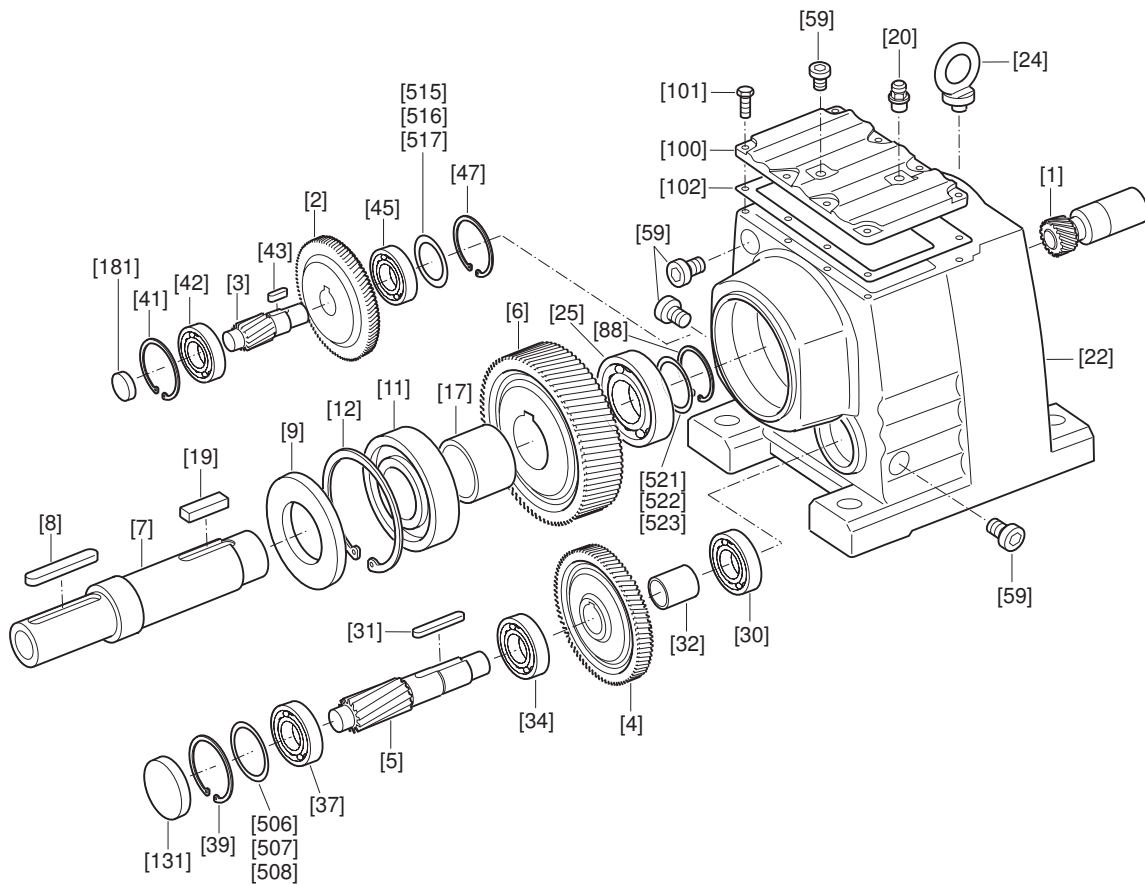

9007199273935243

[1] Pinion	[19] Key	[42] Rolling bearing	[507] Shim
[2] Gear	[20] Breather valve	[43] Key	[508] Shim
[3] Pinion shaft	[22] Gear unit housing	[45] Rolling bearing	[515] Shim
[4] Gear	[24] Eyebolt	[47] Retaining ring	[516] Shim
[5] Pinion shaft	[25] Rolling bearing	[59] Screw plug	[517] Shim
[6] Gear	[30] Rolling bearing	[88] Retaining ring	[521] Shim
[7] Output shaft	[31] Key	[100] Inspection cover	[522] Shim
[8] Key	[32] Spacer tube	[101] Hex head screw	[523] Shim
[9] Oil seal	[34] Rolling bearing	[102] Gasket	
[11] Rolling bearing	[37] Rolling bearing	[131] Closing cap	
[12] Retaining ring	[39] Retaining ring	[181] Closing cap	
[17] Spacer tube	[41] Retaining ring	[506] Shim	

21932786/EN – 05/2015

# 3

## Gear unit structure

Basic structure of parallel-shaft helical gear units

### 3.2 Basic structure of parallel-shaft helical gear units

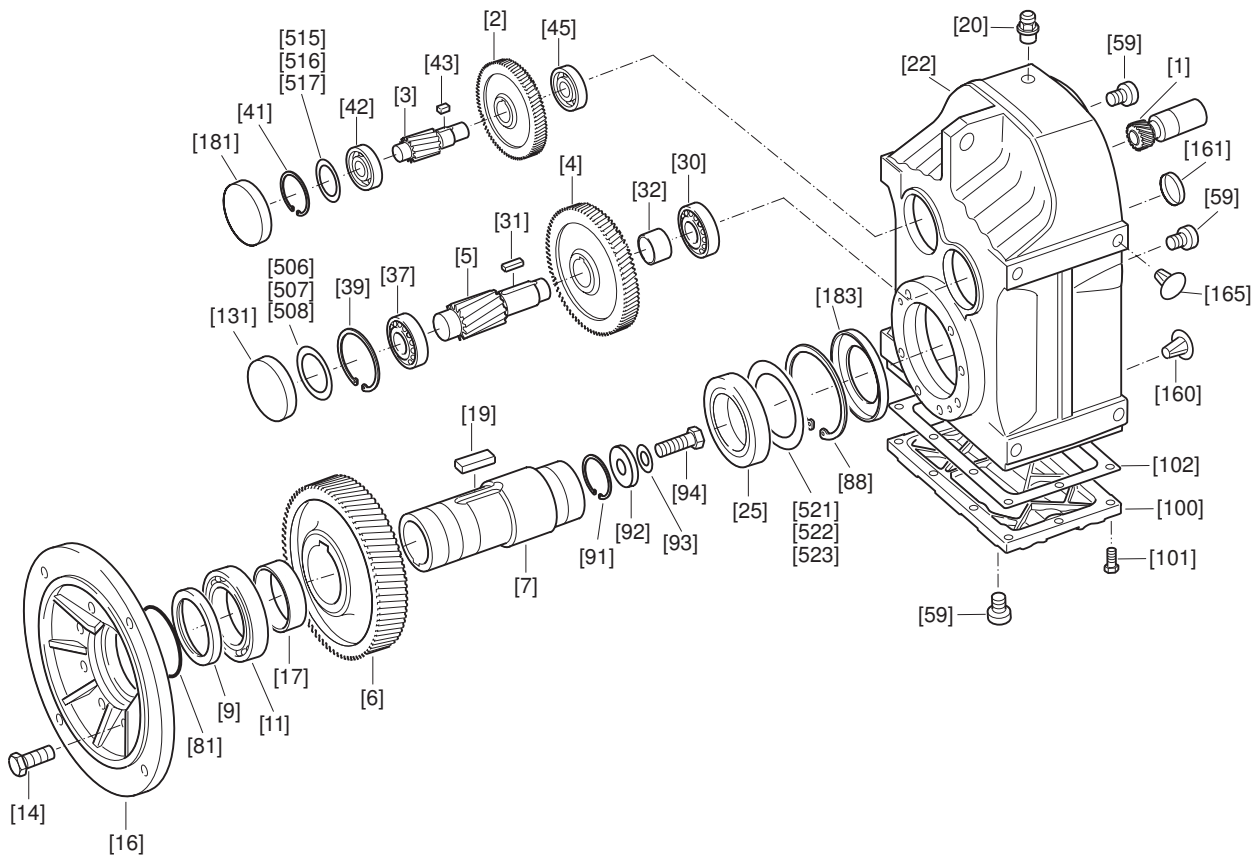

9007199274039051

[1] Pinion	[22] Gear unit housing	[91] Retaining ring	[506] Shim
[2] Gear	[25] Rolling bearing	[92] Washer	[507] Shim
[3] Pinion shaft	[30] Rolling bearing	[93] Lock washer	[508] Shim
[4] Gear	[31] Key	[94] Hex head screw	[515] Shim
[5] Pinion shaft	[32] Spacer tube	[100] Inspection cover	[516] Shim
[6] Gear	[37] Rolling bearing	[101] Hex head screw	[517] Shim
[7] Hollow shaft	[39] Retaining ring	[102] Gasket	[521] Shim
[9] Oil seal	[41] Retaining ring	[131] Closing cap	[522] Shim
[11] Rolling bearing	[42] Rolling bearing	[160] Closing plug	[523] Shim
[14] Hex head screw	[43] Key	[161] Closing cap	
[16] Output flange	[45] Rolling bearing	[165] Closing plug	
[17] Spacer tube	[59] Screw plug	[181] Closing cap	
[19] Key	[81] Shield ring	[183] Oil seal	
[20] Breather valve	[88] Retaining ring		

**3.3 Basic structure of helical-bevel gear units K..19/K..29**

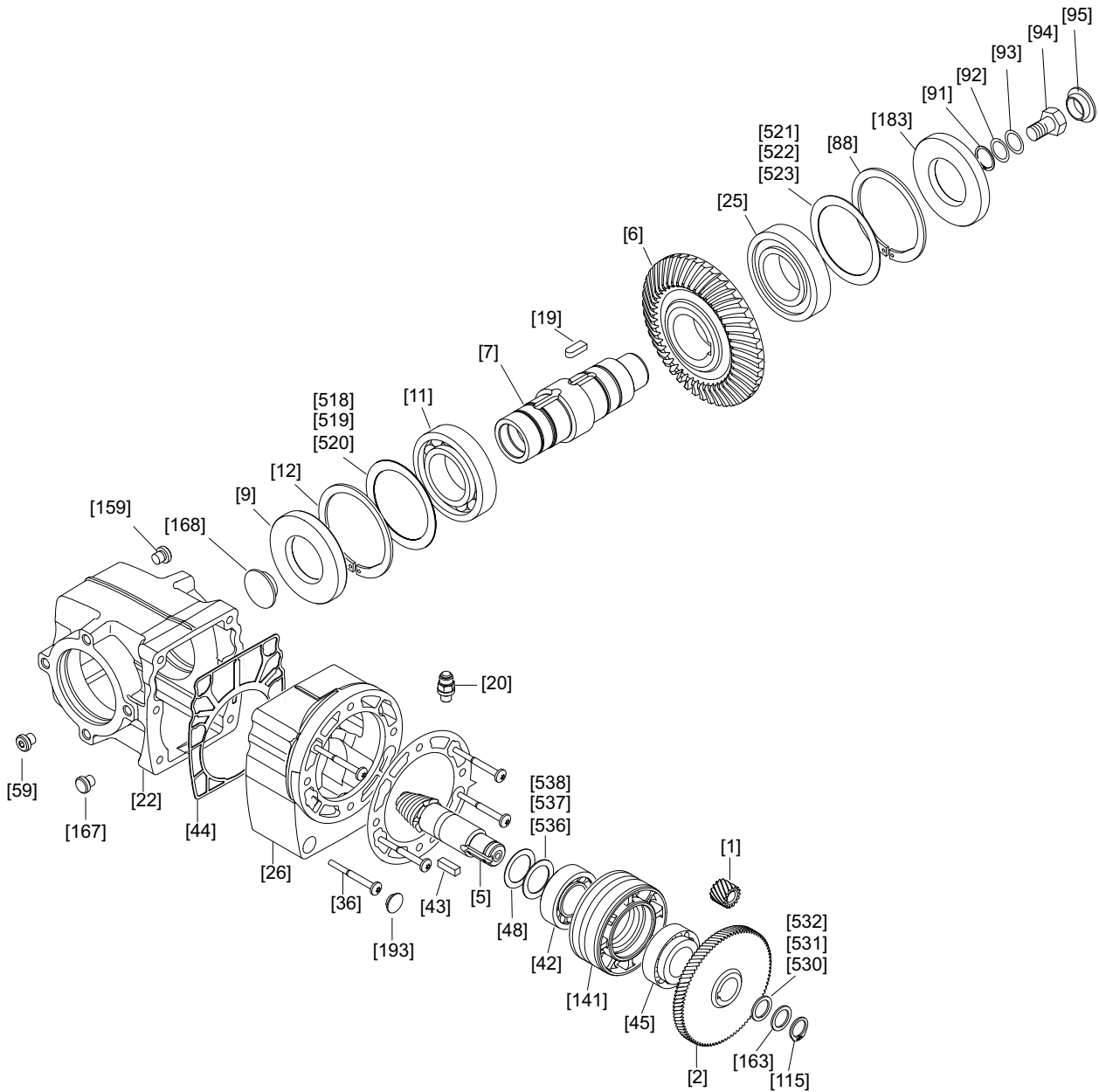

9007206676351499

[1] Pinion	[26] Housing 1. Stage	[94] Hex head screw	[520] Shim
[2] Gear	[36] Stud	[95] Protection cap	[521] Shim
[5] Pinion shaft	[42] Tapered roller bearing	[115] Retaining ring	[522] Shim
[6] Gear	[43] Key	[141] Bushing	[523] Shim
[7] Hollow shaft	[44] Gasket	[159] Closing plug	[530] Shim
[9] Oil seal	[45] Tapered roller bearing	[163] Supporting ring	[531] Shim
[11] Rolling bearing	[50] Bevel gear set	[167] Closing plug	[532] Shim
[12] Retaining ring	[59] Screw plug	[168] Protection cap	[536] Shim
[19] Key	[88] Retaining ring	[183] Oil seal	[537] Shim
[20] Breather valve	[91] Retaining ring	[193] Closing plug	[538] Shim
[22] Gear unit housing	[92] Washer	[518] Shim	
[25] Deep groove ball bearing	[93] Lock washer	[519] Shim	

21932786/EN – 05/2015

# 3

## Gear unit structure

Basic structure of helical-bevel gear units K..39/K..49

### 3.4 Basic structure of helical-bevel gear units K..39/K..49

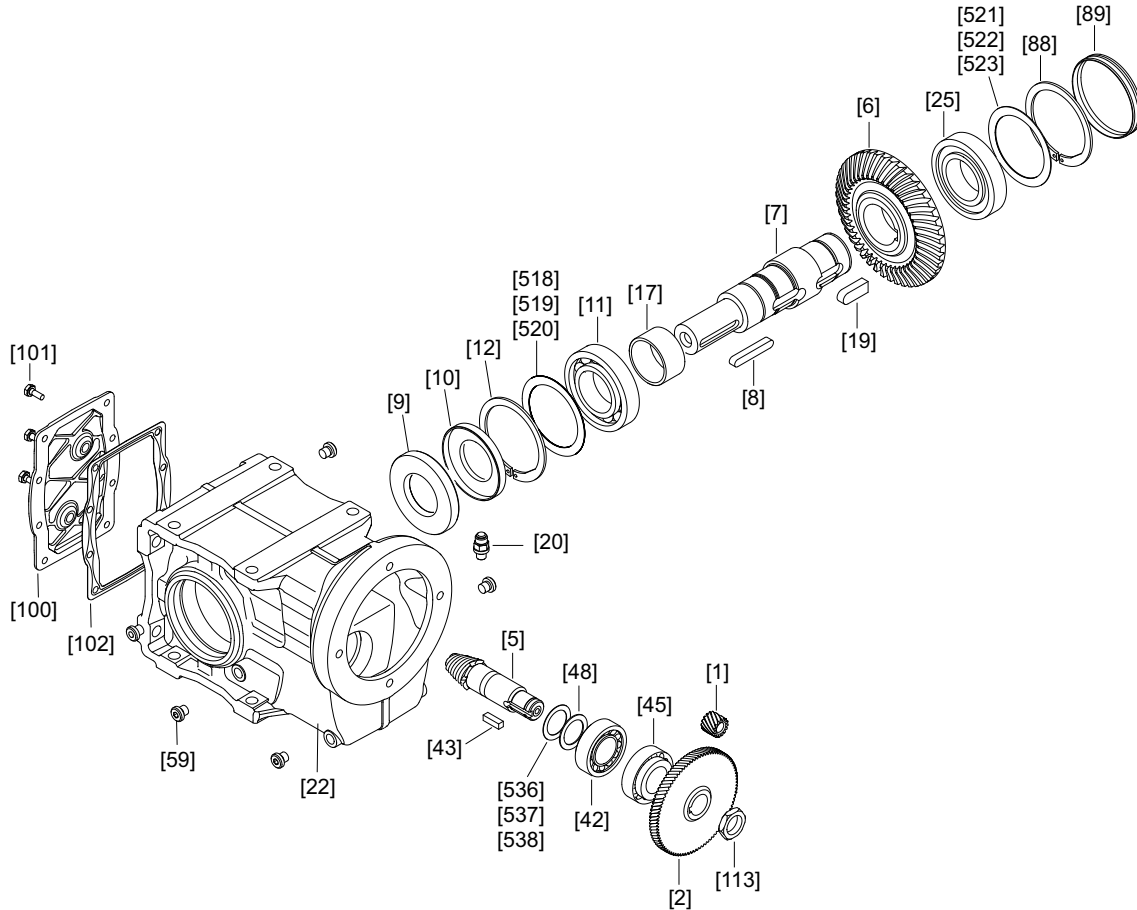

14457456395

[1] Pinion	[12] Retaining ring	[48] Supporting ring	[518] Shim
[2] Gear	[17] Spacer tube	[50] Bevel gear set	[519] Shim
[5] Pinion shaft	[19] Key	[59] Screw plug	[520] Shim
[6] Gear	[20] Breather valve	[88] Retaining ring	[521] Shim
[7] Hollow shaft	[22] Gear unit housing	[89] Closing cap	[522] Shim
[8] Key	[25] Deep groove ball bearing	[100] Inspection cover	[523] Shim
[9] Oil seal	[42] Tapered roller bearing	[101] Hex head screw	[536] Shim
[10] Oil seal	[43] Key	[102] Gasket	[537] Shim
[11] Deep groove ball bearing	[45] Tapered roller bearing	[113] Slotted nut	[538] Shim

**3.5 Basic structure of helical-bevel gear units K..37 – K..187**

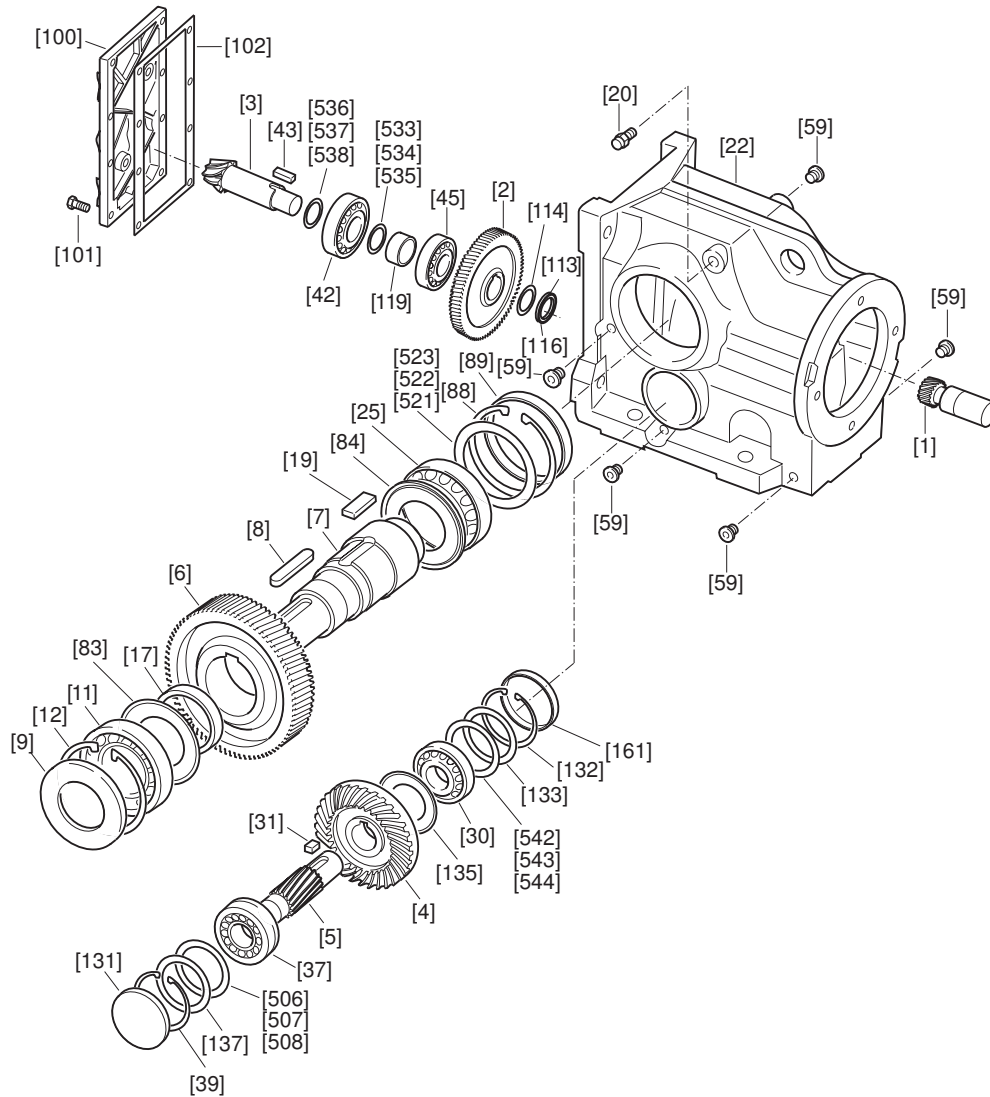

9007199274042123

[1] Pinion	[25] Rolling bearing	[102] Gasket	[522] Shim
[2] Gear	[30] Rolling bearing	[113] Slotted nut	[523] Shim
[3] Pinion shaft	[31] Key	[114] Multi-tang washer	[533] Shim
[4] Gear	[37] Rolling bearing	[116] Thread lock	[534] Shim
[5] Pinion shaft	[39] Retaining ring	[119] Spacer tube	[535] Shim
[6] Gear	[42] Rolling bearing	[131] Closing cap	[536] Shim
[7] Output shaft	[43] Key	[132] Retaining ring	[537] Shim
[8] Key	[45] Rolling bearing	[133] Supporting ring	[538] Shim
[9] Oil seal	[59] Screw plug	[135] Shield ring	[542] Shim
[11] Rolling bearing	[83] Shield ring	[137] Supporting ring	[543] Shim
[12] Retaining ring	[84] Shield ring	[161] Closing cap	[544] Shim
[17] Spacer tube	[88] Retaining ring	[506] Shim	
[19] Key	[89] Closing cap	[507] Shim	
[20] Breather valve	[100] Inspection cover	[508] Shim	
[22] Gear unit housing	[101] Hex head screw	[521] Shim	

21932786/EN – 05/2015

# 3

## Gear unit structure

Basic structure of helical-worm gear units

### 3.6 Basic structure of helical-worm gear units

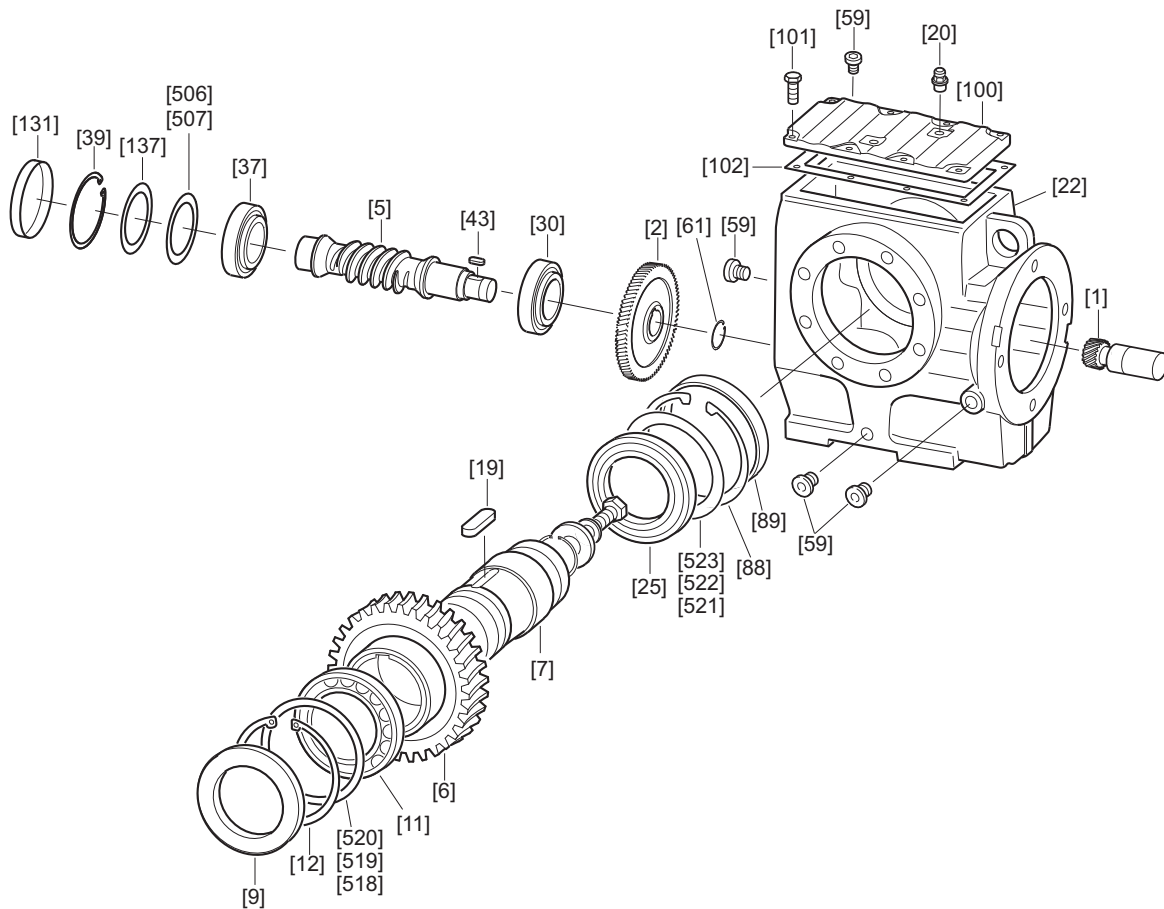

9007199274045195

[1] Pinion	[20] Breather valve	[88] Retaining ring	[518] Shim
[2] Gear	[22] Gear unit housing	[89] Closing cap	[519] Shim
[5] Worm	[25] Rolling bearing	[100] Inspection cover	[520] Shim
[6] Worm gear	[30] Rolling bearing	[101] Hex head screw	[521] Shim
[7] Output shaft	[37] Rolling bearing	[102] Gasket	[522] Shim
[9] Oil seal	[39] Retaining ring	[131] Closing cap	[523] Shim
[11] Rolling bearing	[43] Key	[137] Supporting ring	
[12] Retaining ring	[59] Screw plug	[506] Shim	
[19] Key	[61] Retaining ring	[507] Shim	



**3.7 Basic structure of SPIROPLAN® gear units W..10 – W..30**

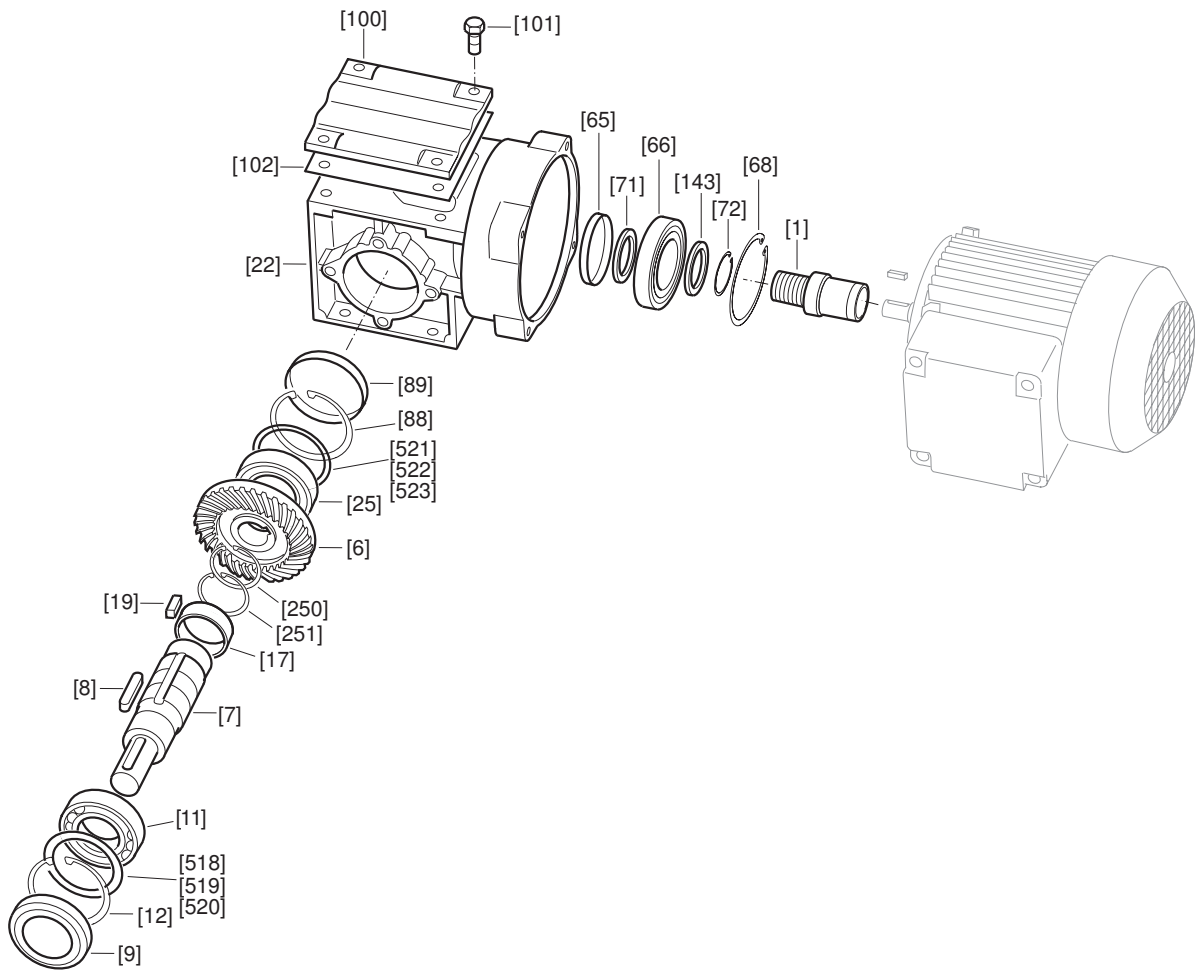

9007199274048267

- |                      |                        |                        |            |
|----------------------|------------------------|------------------------|------------|
| [1] Pinion           | [19] Key               | [88] Retaining ring    | [518] Shim |
| [6] Gear             | [22] Gear unit housing | [89] Closing cap       | [519] Shim |
| [7] Output shaft     | [25] Rolling bearing   | [100] Inspection cover | [520] Shim |
| [8] Key              | [65] Oil seal          | [101] Hex head screw   | [521] Shim |
| [9] Oil seal         | [66] Rolling bearing   | [102] Gasket           | [522] Shim |
| [11] Rolling bearing | [68] Retaining ring    | [143] Supporting ring  | [523] Shim |
| [12] Retaining ring  | [71] Supporting ring   | [250] Retaining ring   |            |
| [17] Spacer tube     | [72] Retaining ring    | [251] Retaining ring   |            |

21932786/EN – 05/2015

# 3

## Gear unit structure

Basic structure of SPIROPLAN® gear units W..37 – W..47

### 3.8 Basic structure of SPIROPLAN® gear units W..37 – W..47

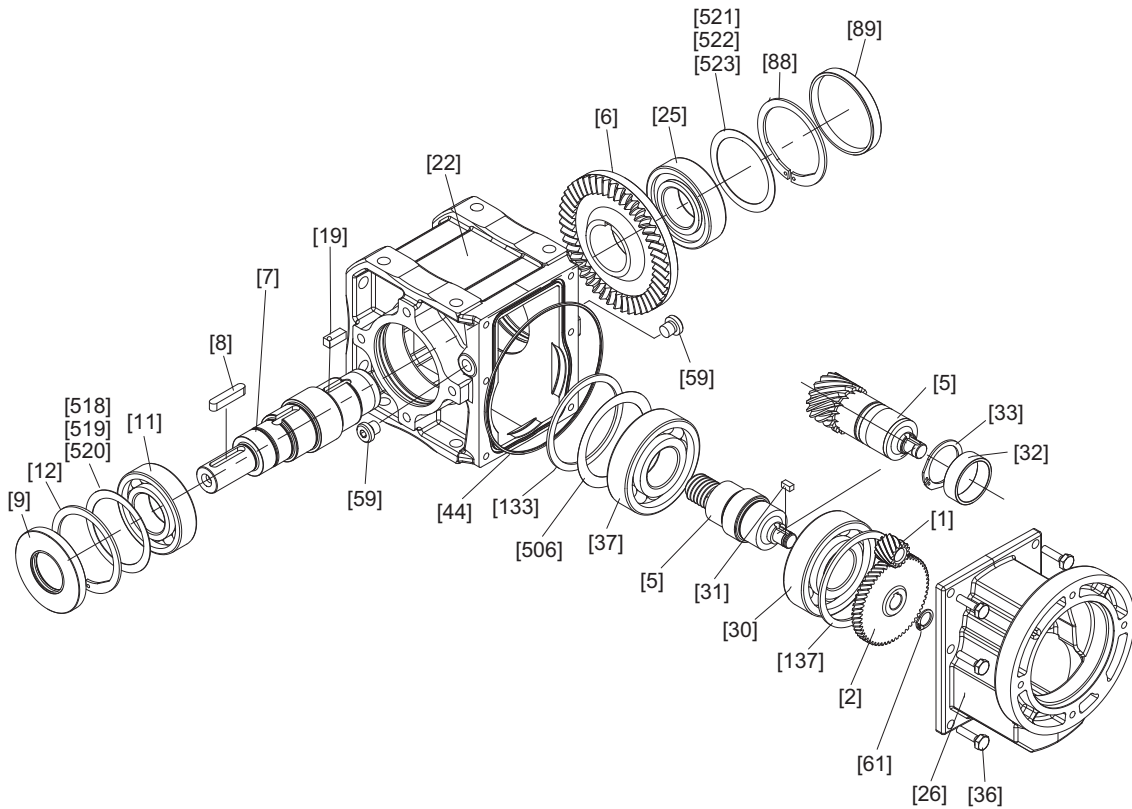

18014399115354379

[1] Pinion	[22] Gear unit housing	[59] Screw plug	[521] Shim
[2] Gear	[25] Deep groove ball bearing	[61] Retaining ring	[522] Shim
[5] Pinion shaft	[26] Housing stage 1	[88] Retaining ring	[523] Shim
[6] Gear	[30] Deep groove ball bearing	[89] Closing cap	
[7] Output shaft	[31] Key	[133] Shim	
[8] Key	[32] Spacer tube	[137] Shim	
[9] Oil seal	[33] Retaining ring	[506] Shim	
[11] Deep groove ball bearing	[36] Hex head screw	[518] Shim	
[12] Retaining ring	[37] Deep groove ball bearing	[519] Shim	
[19] Key	[44] O-ring	[520] Shim	

### 3.9 Nameplate/type designation

#### 3.9.1 Gear unit nameplate

The following figure shows an example of a nameplate for a helical-bevel gear unit with input cover:

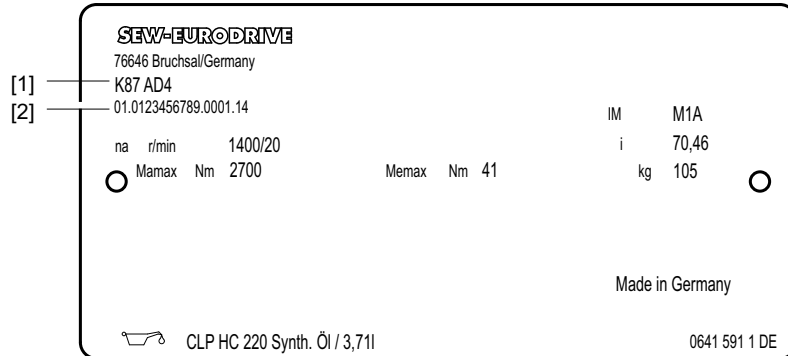

9007203726759691

[1]	Type designation of the gear unit
[2]	Serial number
$n_a$	r/min Maximum permitted output speed
$M_{amax}$	Nm Maximum permitted output torque i
$M_{emax}$	Nm Maximum permitted input torque
$i$	Gear unit ratio
IM	Mounting position

#### Explanation for serial number:

<b>01.</b>	<b>0123456789.</b>	<b>0001.</b>	<b>14</b>
Sales organization	Order number	Item number	Year of manufacture

#### 3.9.2 Type designation of the gear unit

A helical-bevel gear unit with AQA adapter, for example has the following type designation:

Example: K37/R AQA 80 /1		
Gear unit type	<b>K</b>	Helical-bevel gear units
Gear unit size	<b>37</b>	19 – 49; 37 – 187
Option	<b>/R</b>	e.g. option /R for servo drives: Reduced rotational clearance
Adapter	<b>AQA</b>	e.g. adapter for servo drives: AQA: Adapter with keyway AQH: Adapter with clamping ring hub
Flange key figure	<b>80</b>	
Variants	<b>/1</b>	

# 3

## Gear unit structure

### Nameplate/type designation

#### 3.9.3 DRN.. gearmotor nameplate

The following figure shows an example of the nameplate of a DRN.. gearmotor.

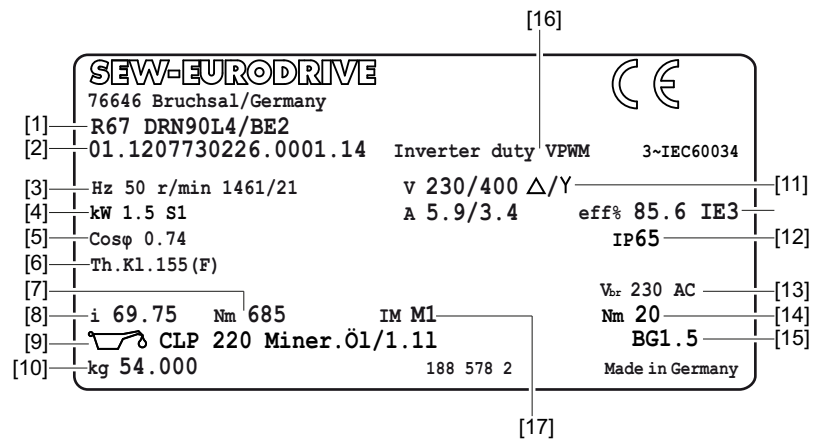

18014411882555659

[1]	Type designation gearmotor
[2]	Serial number
[3]	Hz Line frequency
[4]	kW Motor power
[5]	Power factor
[6]	Temperature class
[7]	Nm Maximum output torque
[8]	Gear unit ratio
[9]	Oil type and oil fill volume
[10]	kg Weight
[11]	V Clamping connection
[12]	Degree of protection
[13]	V Brake voltage
[14]	Nm Braking torque
[15]	Brake control
[16]	Inverter operation
[17]	Mounting position



## 4 Mechanical installation

### 4.1 Prerequisites for installation

#### NOTICE

Damage to the gear unit/gearmotor due to improper installation.

Damage to property.

- Observe the following notes.

Make sure that the following requirements are met before you start installing the unit:

- The drive has not been damaged during transportation or storage.
- The entries on the nameplate of the gearmotor match the voltage supply system.
- In case of abrasive ambient conditions, the output end oil seals must be protected against wear.
- Output shafts and flange surfaces must be completely free from anti-corrosion agent and any kind of pollution. Use a commercially available solvent to clean the flange surfaces. Note that solvent damages the oil seal. Do not let the solvent come into contact with the sealing lips of the oil seals.
- **For standard drives:**
  - Check if the gear unit/gearmotor is designed for the ambient temperatures. For the application limits refer to the technical documentation, the nameplate or the lubricant table (see chapter "Lubricant table (→ 149)").
  - Make sure the environment contains no hazardous substances (oils, acids, gases, vapors, dusts,...) or radiation.
- **For special designs:**
  - Check if the gear unit/gearmotor is designed for the ambient temperatures. You find the application limits on the nameplate.
- **With helical-worm/SPIROPLAN® gear units:**
  - Note that no large external mass moments of inertia must be present, which could exert a retrodriving load on the gear unit.
  - Note the self-locking at  $\eta' \text{ (retrodriving)} < 0.5$ .  
Calculation of  $\eta'$ :  $\eta' = 2 - 1/\eta$
- **Servomotor mounting:**
  - The drive may only be mounted if it is ensured that after the mounting the drive will be sufficiently ventilated. Ventilation prevents heat build-up.

#### 4.1.1 Required tools/resources

The following tools and resources are required for the mechanical installation:

- Wrench
- Torque wrench for:
  - Gear unit mounting
  - Shrink disks
  - Motor adapter AQH or EWH
  - Input shaft assembly with centering shoulder

- Mounting device
- Compensation elements (shims and spacing rings)
- Fasteners for input and output elements
- Lubricant (e.g. NOCO® fluid)
- Threadlocker compound for input cover with centering shoulder (e.g. Loctite® 243)

**INFORMATION**



Standard parts are not included in the delivery.

**4.1.2 Installation tolerances**

Shaft end	Flanges
Diameter tolerance according to DIN 748 <ul style="list-style-type: none"> <li>• ISO k6 for solid shafts with <math>\varnothing \leq 50</math> mm</li> <li>• ISO m6 for solid shafts with <math>\varnothing &gt; 50</math> mm</li> <li>• ISO H7 for hollow shafts</li> <li>• Centering bore in accordance with DIN 332, shape DR</li> </ul>	Centering shoulder tolerance to DIN 42948 <ul style="list-style-type: none"> <li>• ISO j6 with <math>b1 \leq 230</math> mm</li> <li>• ISO h6 with <math>b1 &gt; 230</math> mm</li> </ul>

# 4 Mechanical installation

## Installing the gear unit

### 4.2 Installing the gear unit



#### ▲ CAUTION

Risk of injury due to improper installation/disassembly

Severe personal injury and damage to property.

- Work on the gear unit only when the machine is not in use.
- Secure the drive unit against unintentional power-up.
- Prevent heavy component parts (e.g. shrink disks) against falling during installation/disassembly.



#### ▲ CAUTION

Risk of injury due to protruding gear unit parts.

Severe injuries

- Keep a sufficient safety distance to the gear unit/gearmotor.



#### NOTICE

Danger due to static overdetermination if gear units with foot (e.g. KA19/29B, KA127/157B or FA127/157B) are mounted both via the torque arm and via the foot plate.

Risk of injuries and damage to property.

- Especially with the KA.9B/T design, it is not permitted to use the foot plates and the torque arm at the same time.
- Attach the KA 9B/T design only via the torque arm.
- Attach the K.9 or KA.9B design only via the foot plate.
- If you want to use foot plates and torque arms for mounting, contact SEW-EURODRIVE.

#### NOTICE

Damage to gear unit/gearmotor due to cold air currents. Condensed water in the gear unit can cause damage.

Damage to property.

- Protect the gear unit from direct cold air currents.

#### INFORMATION



When installing the gear unit, make sure that the oil level and drain plugs as well as the breather plugs are easily accessible!

Mounting position

The gear unit or gearmotor is only allowed to be installed in the specified mounting position. Observe the information on the nameplate. SPIROPLAN® gear units of sizes W10-W30 do not depend on a particular mounting position.



**Oil fill volume** Check the oil fill depending on the mounting position (for information on the fill quantity refer to the nameplate or chapter "Lubricant fill quantities" (→ 151)). Control the oil fill level at this opportunity. See chapter "Inspection/maintenance for the gear unit" (→ 95). The gear units are filled with the required oil quantity at the factory. There may be slight deviations at the oil level plug as a result of the mounting position, which are permitted within the manufacturing tolerances.

**Adjust the lubricant fill volumes and the position of the breather valve accordingly in the event of a change of mounting position.** Observe chapter "Lubricant fill quantities" (→ 151) and chapter "Mounting Positions" (→ 110).

Consult the SEW customer service if you intend to change the mounting position of K gear to M5 or M6 or between M5 and M6.

Please contact our SEW customer service if you want to change the mounting position of size S47 – S97 helical-worm gear units to mounting position M2 or M3.

**Submounting** The support structure must have the following characteristics:

- Level
- Vibration damping
- Torsionally rigid

The following table shows the maximally permitted flatness defect for foot- and flange-mounting (guide values based on DIN ISO 1101):

Gear unit size	Flatness defect
≤ 67	max. 0.4 mm
77 – 107	max. 0.5 mm
137/147	max. 0.7 mm
157 – 187	max. 0.8 mm

Do not twist housing legs and mounting flanges against each other. Observe the permitted overhung and axial forces. Observe chapter "Project Planning" in the Gear unit/gearmotor catalog for calculating the permitted overhung and axial loads.

**Screw quality** Secure the gearmotors listed in the following table using quality 10.9 screws. Use suitable washers.

Gear unit	Flange Ø in mm
RF37/R37F	120
RF47/R47F	140
RF57/R57F	160
FF/FAF77/KF/KAF77	250
RF147	450
RF167	550
RZ37 – RZ87	60ZR – 130ZR

Secure the gearmotors not listed in the table using quality 8.8 screws.

**Corrosion protection for screw connections**

Use plastic inserts (2 – 3 mm thick) if there is a risk of electrochemical corrosion between the gear unit and the driven machine. The material used must have an electrical leakage resistance < 10<sup>9</sup> Ω. Electrochemical corrosion can occur between various metals, for example, cast iron and stainless steel. Also fit the screws with plastic washers. Additionally ground the housing. Use grounding screws on the motor.

# 4 Mechanical installation

## Installing the gear unit

### 4.2.1 Tightening torques for retaining screws

Mount the gearmotors with the following tightening torques:

Screw/nut	Tightening torque $\pm 10\%$ Strength class 8.8 Nm
M6	11
M8	25
M10	48
M12	86
M16	210
M20	410
M24	710
M30	1450
M36	2500
M42	4600
M48	6950
M56	11100

Mount the specified gearmotors in flange-mounted design with the following increased tightening torques:

Flange $\varnothing$ mm	Gear unit	Screw/nut	Tightening torque $\pm 10\%$ Strength class 10.9 Nm
120	RF37	M6	16.5
140	RF37/RF47	M8	40.1
160	RF57	M8	40.1
450	RF147	M20	661
550	RF167	M20	661
60ZR	RZ37	M8	40
70ZR	RZ47	M8	40
80ZR	RZ57	M10	79
95ZR	RZ67	M10	79
110ZR	RZ77	M10	79
130ZR	RZ87	M12	137
250	FF77/KF77/FAF77/KAF77	M12	137

## 4.2.2 Gear unit mounting

## INFORMATION



If you use the gear unit in flange-mounted design or foot/flange-mounted design with VARIGEAR® variable speed gear units, use screws of 10.9 quality and suitable washers for flange mounting on customer side.

To improve the friction contact between flange and mounting surface, SEW-EURODRIVE recommends anaerobic gaskets or anaerobic glue.

## Foot-mounted gear unit

The following table shows the thread sizes of the gear units in foot-mounted design depending on the gear unit type and size:

Screw	Gear unit type					
	R/R..F	RX	F/FH..B/ FA..B	K/KH..B/KV..B/ KA..B	S	W
M6	07	-	-	19	-	10/20
M8	17/27/37	-	27/37	29	37	30/37/47
M10	-	57	47	37/39/47/49	47/57	-
M12	47/57/67	67	57/67	57/67	67	-
M16	77/87	77/87	77/87	77	77	-
M20	97	97/107	97	87	87	-
M24	107	-	107	97	97	-
M30	137	-	127	107/167	-	-
M36	147/167	-	157	127/157/187	-	-

## Gear unit with B14 flange-mounted design and/or hollow shaft

The following table shows the thread sizes of the gear units with B14 flange and/or hollow shaft depending on the gear unit type and size:

Screw	Gear unit type				
	RZ	FZ/FAZ/FHZ/ FVZ	KZ/KAZ/KHZ/KVZ	SA/SAZ/SHZ	WA
M6	07/17/27	-	-	37	10/20/30 <sup>1)</sup>
M8	37/47	27/37/47	37/47	47/57	37
M10	57/67	-	-	-	47
M12	77/87	57/67/77	57/67/77	67/77	-
M16	-	87/97	87/97	87/97	-
M20	-	107/127	107/127	-	-
M24	-	157	157	-	-

1) For W30 gear units mounted directly to a CMP motor or mounted via an EWH.. adapter, the thread size is M8.

# 4 Mechanical installation

## Installing the gear unit

### Gear unit with B5 flange

The following table shows the thread sizes of the gear units with B5 flange depending on the gear unit type, size and flange diameter:

Flange Ø mm	Screw	Gear unit type				
		RF/R..F/RM	FF/FAF/ FHF/FVF	KF/KAF/ KHF/KVF	SF/SAF/SHF	WF/WAF/ WHF
80	M6	-	-	-	-	10
110	M8	-	-	-	-	20
120	M6	07/17/27	-	-	37	10/20/30/37
120	M8	-	-	19	-	-
140	M8	07/17/27/37/47	-	-	-	-
160	M8	07/17/27/37/47	27/37	19/37	37/47	30/37/47
160	M10	-	-	29/39	-	-
200	M10	37/47/57/67	47	29/47	57/67	-
200	M12	-	-	49	-	-
250	M12	57/67/77/87	57/67	57/67	77	-
300	M12	67/77/87	77	77	-	-
350	M16	77/87/97/107	87	87	87	-
450	M16	97/107/137/147	97/107	97/107	97	-
550	M16	107/137/147/167	127	127	-	-
660	M20	147/167	157	157	-	-

### 4.2.3 Installation in damp locations or outdoors

Drives are supplied in corrosion-resistant designs with an according surface protection coating for use in damp areas or outdoors.

- Repair damage to the paint work e.g. at the breather valve or the lifting eyes (see "Painting the gear unit" (→ 30)).
- When mounting the motors onto AM, AQ adapters and to AR, AT start-up and friction couplings, seal the flange areas with a suitable sealant (e.g. Loctite® 574).
- Units installed outdoors must be protected from the sun. Provide for suitable protective devices such as covers or roofs. Avoid heat build-up.
- The system operator must ensure that no foreign objects (e.g. falling objects or coverings) affect the operation of the gear unit.

### 4.2.4 Gear unit venting

#### NOTICE

Dirt and dust in the environment affect the function of the breather valve.

Possible damage to property.

- Check the breather valve function regularly and replace it if necessary.
- In case of high dirt and dust load use a breather filter instead of a breather valve.

21932786/EN – 05/2015

The following table lists gear units that do not require venting:

Gear unit	Mounting position
R..07	M1/M2/M3/M5/M6
R..17/R..27/F..27	M1/M3/M5/M6
W..10/W..20/W..30	M1– M6
W..37/W..47/	M1/M2/M3/M5/M6
K..19/K..29	M1/M2/M3/M5/M6

All other gear units are delivered with a breather valve suitable to the mounting position and activated.

#### Exceptions:

- The following gear units are delivered with a screw plug on the provided breather hole:
  - Gear units with pivoted mounting positions, if possible
  - Gear units for inclined mounting

Before startup, replace the highest screw plug in the terminal box of the motor with the breather valve provided.
- For **gear head units** venting on the input end, a breather valve is supplied in a plastic bag.
- Enclosed gear units** are delivered without a breather valve.
- In some countries, the breather valve is installed, but not activated due to possible pressure fluctuations during transport. In such cases the transport protection must be removed. This activates the breather valve (see chapter "Activating the breather valve" (→ 29)).

#### Activating the breather valve

Check whether the breather valve is activated. If the breather valve has not been activated, you must remove the transport protection device from the breather valve before starting up the gear unit!

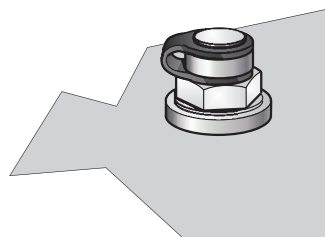

9007199466060043

Breather valve with transport protection

# 4 Mechanical installation

## Installing the gear unit

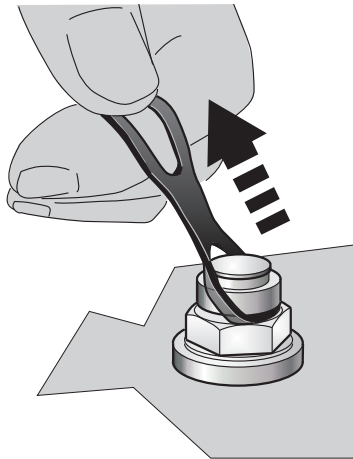

211316875

Removing the transport protection

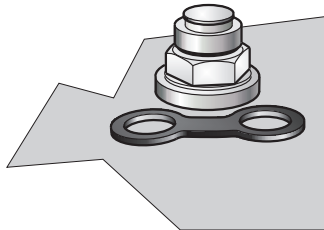

211314699

Activated breather valve

### 4.2.5 Painting the gear unit

#### NOTICE

Paint can block the breather valve and damage the sealing lips of the oil seals.

Damage to property.

- Thoroughly cover the breather valve and sealing lip of the oil seals with strips prior to painting/re-painting.
- Remove the strips after painting.

### 4.3 Gear unit with solid shaft

#### 4.3.1 Information about assembly

#### INFORMATION



Assembly of the shaft is easier if you first apply lubricant to the output element or heat it up briefly (80 °C – 100 °C).

#### 4.3.2 Assembling input and output elements

#### NOTICE

Damage to bearing, housing or shafts due to incorrect mounting

Possible damage to property.

- Only use a mounting device for installing input and output elements (see chapter "Using the mounting device" (→ 31)). Use the threaded centering bore at the shaft end.
- Never force belt pulleys, couplings, pinions, etc. onto the shaft end by hitting them with a hammer.
- In the case of belt pulleys, make sure the belt is tensioned correctly in accordance with the manufacturer's instructions.
- Make sure the transmission elements are balanced after fitting and do not give rise to any impermissible radial or axial forces. For the approved values, refer to the catalog "Gearmotors" or "Explosion-Proof Drives".

#### Using a mounting device

The following figure shows a mounting device for installing couplings or hubs on gear unit or motor shaft ends. Should you be able to tighten the screw without any problems, you may not need the thrust bearing on the mounting device.

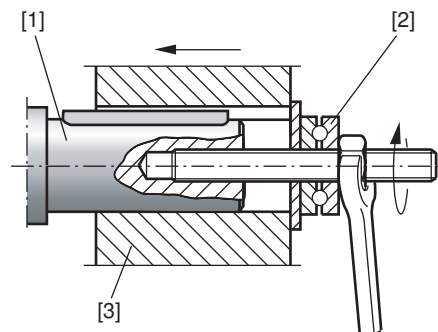

211368587

[1] Gear shaft end  
[2] Thrust bearing

[3] Coupling hub

# 4 Mechanical installation

Gear unit with solid shaft

## Avoiding excessive overhung loads

To avoid high overhung loads, mount gears and sprockets according to figure B.

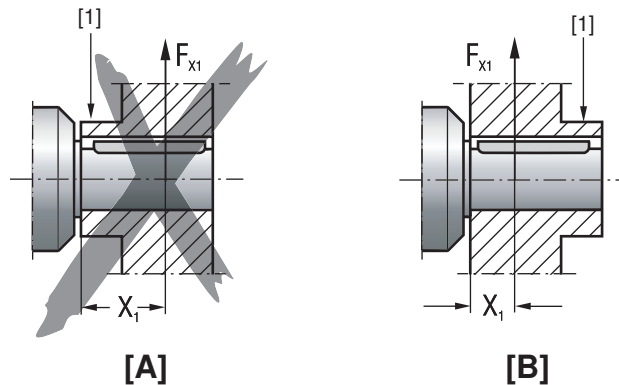

211364235

[1] Hub  
[A] Incorrect assembly

$F_{x1}$  Overhung load at point X1  
[B] Correct assembly

### 4.3.3 Mounting of couplings



#### CAUTION

Risk of injury due to moving drive elements, such as belt pulleys or couplings, during operation.

Risk of jamming and crushing.

- Equip the input and output elements with a touch guard.

Adjust the following misalignments according to the coupling manufacturer's specifications when mounting couplings:

- Maximum and minimum clearance
- Axial misalignment
- Angular misalignment

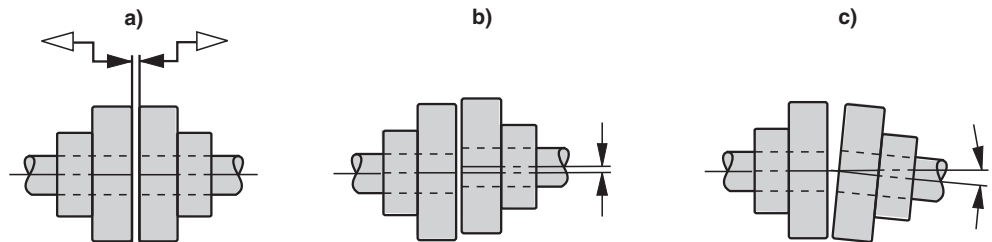

211395595



4.4 Torque arms for shaft-mounted gear units

**NOTICE**

Damage to gear unit due to improper installation.

Damage to the gear unit

- Do not place torque arms under strain during installation.
- Always use bolts of quality 8.8 to fasten torque arms.

4.4.1 Mounting torque arms for parallel-shaft helical gear units

The following figure shows the torque support for parallel-shaft helical gear units.

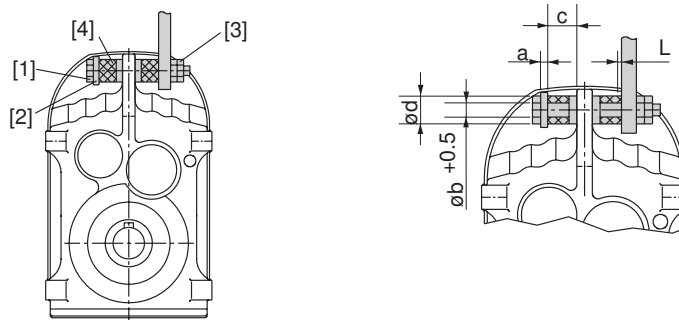

18014398720848395

- |                   |   |
|-------------------|---|
| [1] Screw         | a Washer width                                  |
| [2] Washer        | b Rubber buffer inner diameter                  |
| [3] Nuts          | c Rubber buffer length in loose state           |
| [4] Rubber buffer | d Rubber buffer diameter                        |
|                   | $\Delta L$ Rubber buffer preload in loose state |

Proceed as follows:

1. Use screws [1] and washers [2] according to the following table.
2. Secure the screw connection with a nut [3].
3. Tighten the screw [1] until the preload " $\Delta L$ " of the rubber buffers is reached according to the table:

Gear unit	Washer a mm	Rubber buffer			
		d mm	b mm	c mm	$\Delta L$ mm
F..27 /G	5	40	12.5	20	1
F..37 /G	5	40	12.5	20	1
F..47 /G	5	40	12.5	20	1.5
F..57 /G	5	40	12.5	20	1.5
F..67 /G	5	40	12.5	20	1.5
F..77 /G	10	60	21.0	30	1.5
F..87 /G	10	60	21.0	30	1.5
F..97 /G	12	80	25.0	40	2
F..107 /G	12	80	25.0	40	2
F..127 /G	15	100	32.0	60	3
F..157 /G	15	120	32.0	60	3

21932786/EN – 05/2015



4.4.3 Mounting torque arms for helical-bevel gear unit K..37 – K..157

The following figure shows the torque support for the helical-bevel gear units K..37 – K..157.

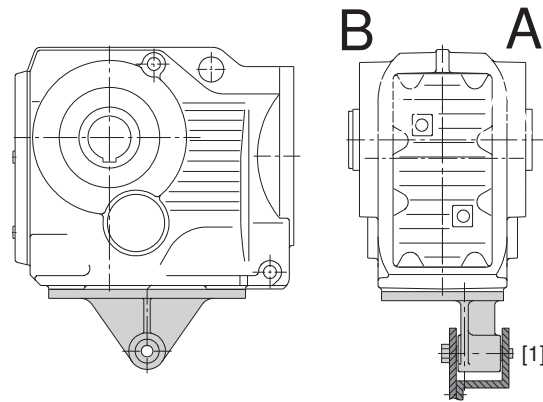

9007199466103051

[1] Bushing

A Connection side

B Connection side

Proceed as follows:

1. Apply bearings to both sides of the bushing [1].
2. Mount connection side B so that it mirrors side A.
3. Use screws and tightening torques according to the following table:

Gear unit	Screws	Tightening torque ± 10 % Nm
K..37 /T	4 × M10 × 25 – 8.8	48
K..47 /T	4 × M10 × 30 – 8.8	48
K..57 /T	4 × M12 × 35 – 8.8	86
K..67 /T	4 × M12 × 35 – 8.8	86
K..77 /T	4 × M16 × 40 – 8.8	210
K..87 /T	4 × M16 × 40 – 8.8	210
K..97 /T	4 × M20 × 50 – 8.8	410
K..107 /T	4 × M24 × 60 – 8.8	710
K..127 /T	4 × M36 × 130 – 8.8	2500
K..157 /T	4 × M36 × 130 – 8.8	2500

# 4

## Mechanical installation

### Torque arms for shaft-mounted gear units

#### 4.4.4 Mounting torque arms for helical-worm gear units

The following figure shows the torque support for helical-worm gear units.

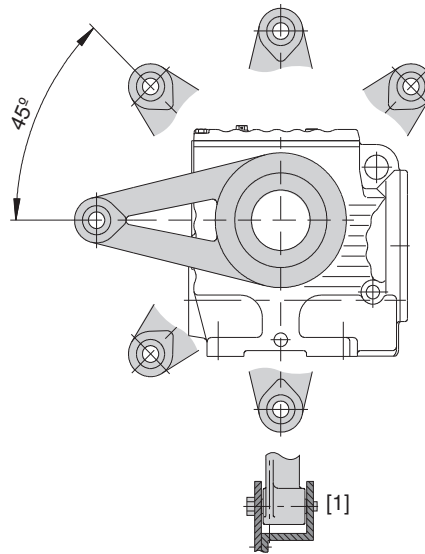

9007199466232715

[1] Bushing

Proceed as follows:

1. Apply bearings to both sides of the bushing [1].
2. Use screws and tightening torques according to the following table:

Gear unit	Screws	Tightening torque $\pm 10\%$ Nm
S..37 /T	4 x M6 x 16 – 8.8	11
S..47 /T	4 x M8 x 25 – 8.8	25
S..57 /T	6 x M8 x 25 – 8.8	25
S..67 /T	4 x M12 x 35 – 8.8	86
S..77 /T	4 x M12 x 35 – 8.8	86
S..87 /T	4 x M16 x 45 – 8.8	210
S..97 /T	4 x M16 x 50 – 8.8	210

21932786/EN – 05/2015

4.4.5 Mounting torque arms for SPIROPLAN® W gear units

The following figure shows the torque support for SPIROPLAN® W gear units.

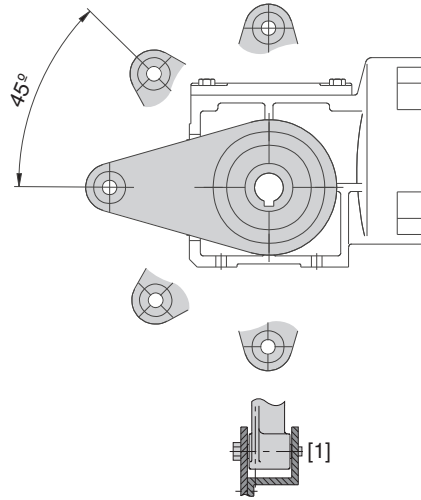

9007199466230539

[1] Bushing

Proceed as follows:

1. Apply bearings to both sides of the bushing [1].
2. Use screws and tightening torques according to the following table:

Gear unit	Screws	Tightening torque ± 10 % Nm
W..10 /T	4 x M6 × 16 - 8.8	11
W..20 /T	4 x M6 × 16 - 8.8	11
W..30 /T	4 x M6 × 16 - 8.8	11
W..37 /T	4 x M8 × 20 - 8.8	25
W..47 /T	4 x M10 × 20 - 8.8	48

### 4.5 Shaft-mounted gear units with keyway or splined hollow shaft

#### INFORMATION



Concerning the configuration of the customer shaft, please also refer to the design notes in the "Gearmotors" catalog.

#### 4.5.1 Mounting the shaft-mounted gear unit

Proceed as follows:

1. Apply NOCO® fluid. Spread carefully.

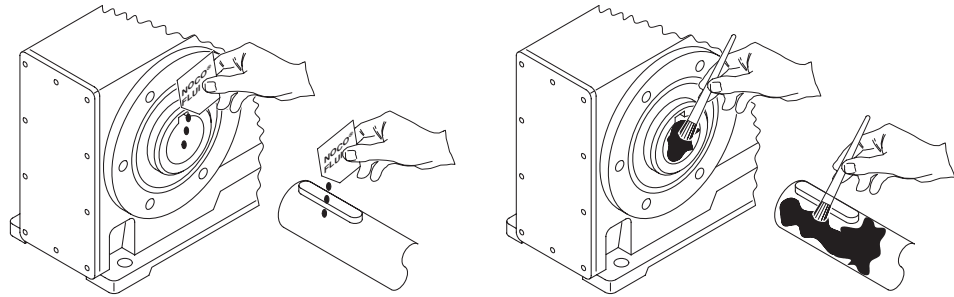

9007199466257163

2. Install the shaft and secure it axially. For easier mounting, use a mounting device. Following a description of the **3 mounting types**, depending on the scope of delivery.

- **Mount customer shaft (standard scope of delivery):**

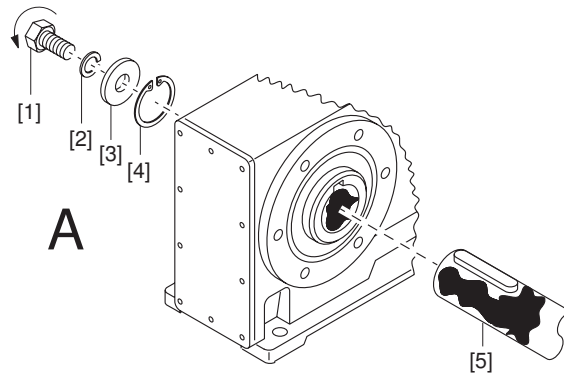

9007199466259339

[1] Short retaining screw  
(standard scope of delivery)

[2] Lock washer

[3] Washer

[4] Retaining ring

[5] Customer shaft

- **Mount customer shaft with contact shoulder using the SEW-EURODRIVE assembly/disassembly kit:**

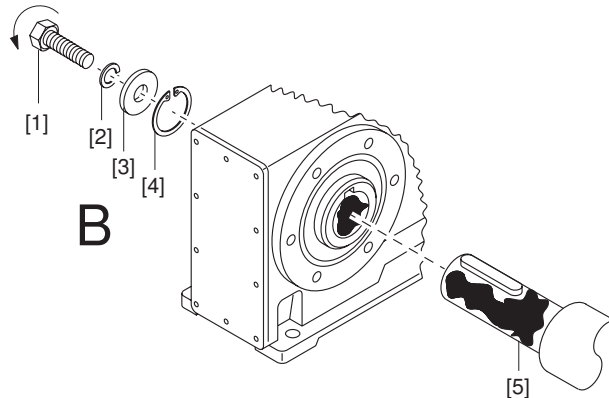

9007199466261515

- |     |                 |     |                                      |
|-----|-----------------|-----|--------------------------------------|
| [1] | Retaining screw | [4] | Retaining ring                       |
| [2] | Lock washer     | [5] | Customer shaft with contact shoulder |
| [3] | Washer          |     |                                      |

- **Mount customer shaft without contact shoulder using the SEW-EURODRIVE assembly/disassembly kit:**

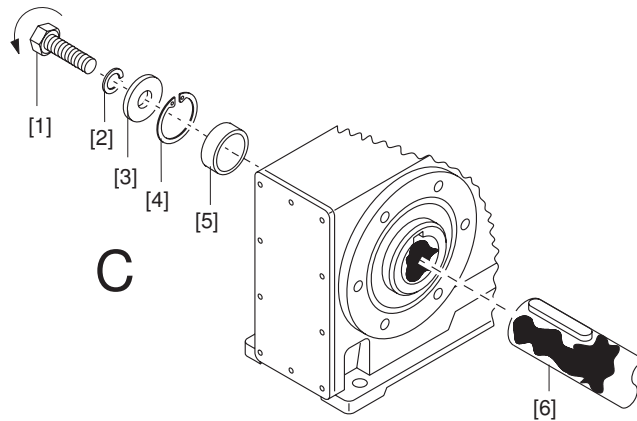

9007199466263691

- |     |                 |     |   |
|-----|-----------------|-----|---|
| [1] | Retaining screw | [4] | Retaining ring                          |
| [2] | Lock washer     | [5] | Spacer tube                             |
| [3] | Washer          | [6] | Customer shaft without contact shoulder |

3. Tighten the retaining screw to the appropriate torque. Observe the tightening torques specified in the following table.

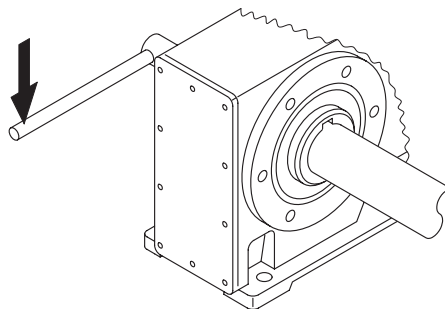

9007199466265867

# 4 Mechanical installation

Shaft-mounted gear units with keyway or splined hollow shaft

Screw	Tightening torque Nm
M5	5
M6	8
M10/12	20
M16	40
M20	80
M24	200

## INFORMATION



To avoid contact corrosion, SEW-EURODRIVE recommends that the customer shaft should be lathed down between the 2 contact surfaces.

### 4.5.2 Remove the shaft-mounted gear unit

This description is only applicable when the gear unit was assembled using the SEW-EURODRIVE assembly/disassembly kit (see step 2 of "Mount the shaft-mounted gear unit" (→ 38)).

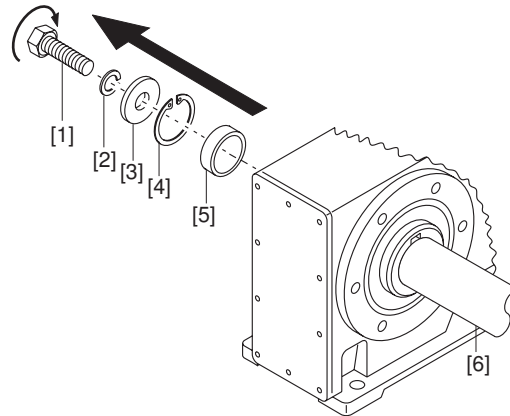

9007199466268043

- |     |                 |     |                |
|-----|-----------------|-----|----------------|
| [1] | Retaining screw | [4] | Retaining ring |
| [2] | Lock washer     | [5] | Spacer tube    |
| [3] | Washer          | [6] | Customer shaft |

Proceed as follows:

1. Loosen the retaining screw [1].
2. Remove parts [2] to [4] and, if applicable, the spacer tube [5].
3. Insert the forcing washer [8] and the fixed nut [7] from the SEW-EURODRIVE assembly/disassembly kit between the customer shaft [6] and the retaining ring [4] (see "SEW-EURODRIVE assembly/disassembly kit" (→ 42)).



4. Re-install the retaining ring [4].
5. Re-install the retaining screw [1]. Press the gear unit off the shaft by tightening the screw.

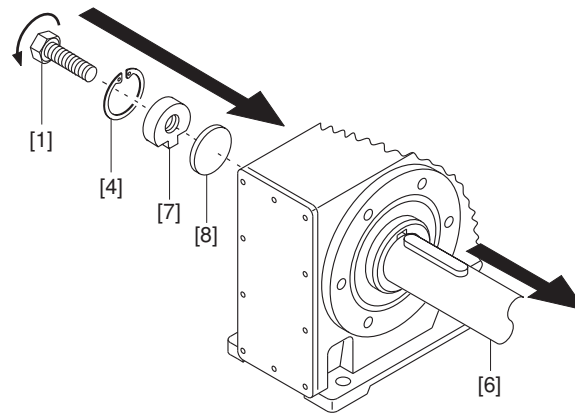

9007199466270219

- |     |                 |     |                |
|-----|-----------------|-----|----------------|
| [1] | Retaining screw | [7] | Fixed nut      |
| [4] | Retaining ring  | [8] | Forcing washer |
| [6] | Customer shaft  |     |                |

# 4 Mechanical installation

Shaft-mounted gear units with keyway or splined hollow shaft

## 4.5.3 Assembly/disassembly kit by SEW-EURODRIVE

### INFORMATION



The depicted assembly kit for attaching the customer shaft is a recommendation by SEW-EURODRIVE.

- You must always check whether this design can compensate the present axial loads.
- In particular applications (e.g. mounting agitator shafts), a different design may have to be used to secure the shaft axially. You can use your own devices to secure the shaft axially, if you ensure that these designs do not cause potential sources of combustion according to DIN EN 13463 (e.g. impact sparks).

The following figure shows the SEW-EURODRIVE assembly/disassembly kit.

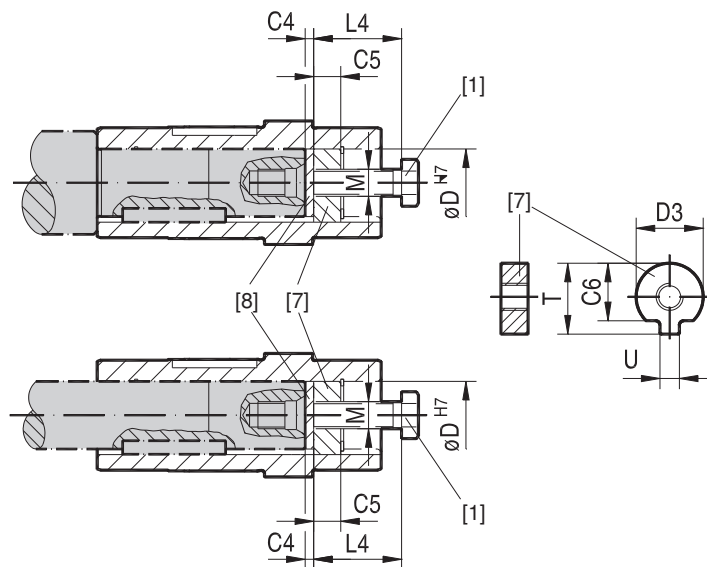

9007199466272395

- [1] Retaining screw  
 [7] Locked nut for removal  
 [8] Forcing washer

For the assembly/disassembly kit part numbers necessary to order, refer to the following table:

Gear unit type	D <sup>H7</sup> mm	M <sup>1)</sup>	C4 mm	C5 mm	C6 mm	U <sup>-0.5</sup> mm	T <sup>-0.5</sup> mm	D3 <sup>-0.5</sup> mm	L4 mm	Part number of the installation/ removal kit
WA..10	16	M5	5	5	12	4.5	18	15.7	50	643 712 5
WA..20	18	M6	5	6	13.5	5.5	20.5	17.7	25	643 682 X
KA..19, SA..37, WA..20, WA..30, WA..37,	20	M6	5	6	15.5	5.5	22.5	19.7	25	643 683 8
FA..27, KA..29, SA..47, WA..47,	25	M10	5	10	20	7.5	28	24.7	35	643 684 6
FA..37, KA..29, KA..37, KA..39, SA..47, SA..57, WA..47	30	M10	5	10	25	7.5	33	29.7	35	643 685 4
FA..47, KA..39, KA..47, KA..49, SA..57	35	M12	5	12	29	9.5	38	34.7	45	643 686 2
FA..57, FA..67, KA..49, KA..57, KA..67, SA..67	40	M16	5	12	34	11.5	41.9	39.7	50	643 687 0
SA..67	45	M16	5	12	38.5	13.5	48.5	44.7	50	643 688 9
FA..77, KA..77, SA..77	50	M16	5	12	43.5	13.5	53.5	49.7	50	643 689 7
FA..87, KA..87, SA..77, SA..87	60	M20	5	16	56	17.5	64	59.7	60	643 690 0
FA..97, KA..97, SA..87, SA..97	70	M20	5	16	65.5	19.5	74.5	69.7	60	643 691 9
FA..107, KA..107	80	M20	5	20	75.5	21.5	85	79.7	70	106 8211 2

Gear unit type	D <sup>H7</sup> mm	M <sup>1)</sup>	C4 mm	C5 mm	C6 mm	U <sup>-0.5</sup> mm	T <sup>-0.5</sup> mm	D3 <sup>-0.5</sup> mm	L4 mm	Part number of the installation/ removal kit
FA..107, KA..107, SA..97	90	M24	5	20	80	24.5	95	89.7	70	643 692 7
FA..127, KA..127	100	M24	5	20	89	27.5	106	99.7	70	643 693 5
FA..157, KA..157	120	M24	5	20	107	31	127	119.7	70	643 694 3

1) Retaining screw

## 4.6 Shaft-mounted gear unit with shrink disk

### 4.6.1 Mounting the shaft-mounted gear unit

#### NOTICE

Deformation of the hollow shaft due to tightening the clamping screws without first installing the shaft.

Damages to the hollow shaft.

- Never tighten the screws without the shaft installed.

Proceed as follows:

1. Slightly loosen the locking screws. Do not remove the locking screws completely.

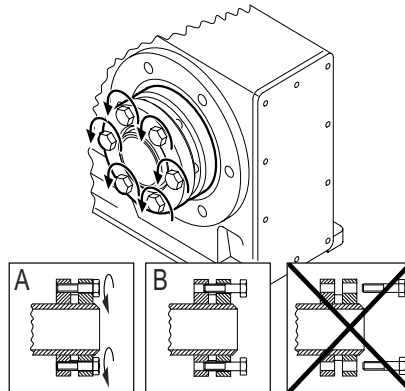

9007199466274571

2. Carefully **degrease** the hollow shaft bore and the input shaft using a commercial solvent.

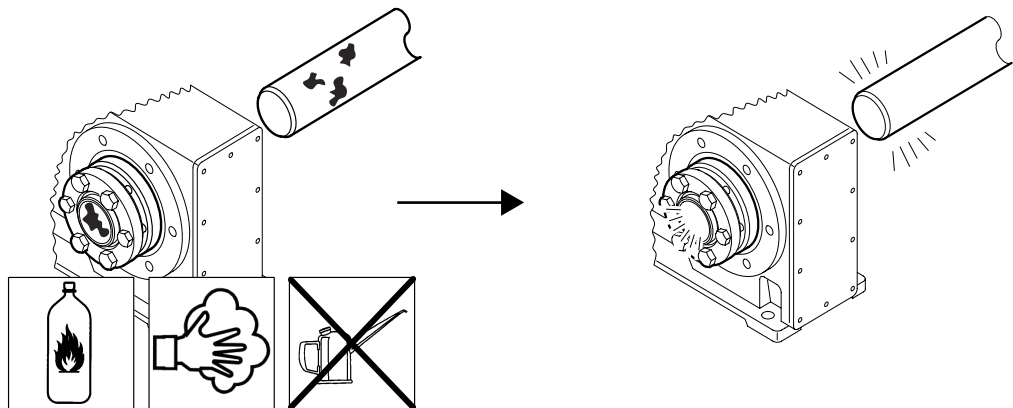

9007199466276747

3. Only apply NOCO® fluid to the input shaft around the bushing.

#### NOTICE

The hollow shaft mounting system is without function if NOCO® fluid is applied directly to the bushing. When the input shaft is installed, NOCO® fluid can get into the clamping area of the shrink disk.

Possible damage to property

- Never apply NOCO® fluid directly to the bushing. The clamping area of the shrink disk must be absolutely free of grease.

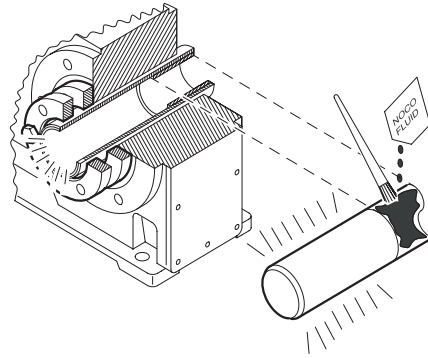

9007199466281099

4. Install the input shaft. Proceed as follows:

- Make sure that the outer rings of the shrink disk are plane-parallel.
- In case of a gear unit housing with shaft shoulder, mount the shrink disk to stop at the shaft shoulder.
- In case of a gear unit without shaft shoulder, mount the shrink disk with a distance of 1 mm to 2 mm from the gear unit housing.
- Tighten the clamping screws with the specified tightening torque according to the following table. Tighten the screws in several turns. Tighten screws one after the other, not in diametrically opposite sequence.

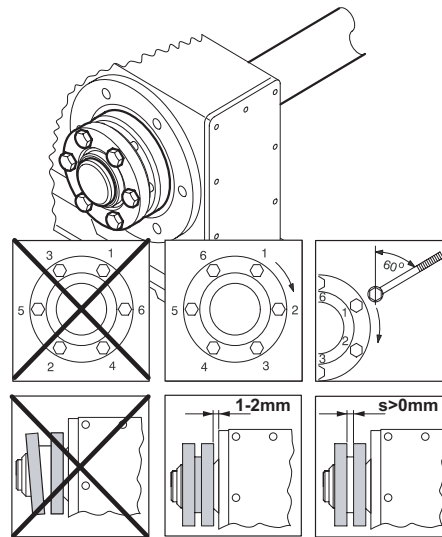

211542283

**INFORMATION**



The exact values for the tightening torques are shown on the shrink disk.

Gear unit type				Clamping screws 10.9 ISO 4014 / ISO 4017	Tightening torque Nm
KH19/29	FH27	SH37	WH37	M5	5
KH37/47/ 57/67/77	FH37/47/ 57/67/77	SH47/57/ 67/77	WH47	M6	12
KH87/97	FH87/97	SH87/97	–	M8	30
KH107	FH107	–	–	M10	59
KH127/157	FH127/157	–	–	M12	100
KH167				M16	250
KH187				M20	470

21932786/EN – 05/2015

5. After installation, make sure the remaining gap "s" between the outer rings of the shrink disk is > 0 mm.
6. To prevent corrosion, grease the outside of the hollow shaft around the shrink disk.

#### 4.6.2 Remove the shaft-mounted gear unit

Proceed as follows:

1. To prevent the outer rings from jamming, loosen the clamping screws for a quarter turn, one after the other.
2. Steadily loosen the clamping screws one after the other, but do not remove the clamping screws completely.
3. If rust has formed on the shaft in front of the hub, remove the rust.
4. Remove the shaft or pull the hub off the shaft.
5. Remove the shrink disk from the hub.

#### 4.6.3 Cleaning and lubricating shaft-mounted gear units

### INFORMATION



There is no need to dismantle removed shrink disks before they are reinstalled.

Proceed as follows:

1. If the shrink disk is dirty, clean and lubricate the shrink disk.
2. Lubricate the tapered surfaces. Use one of the following solid lubricants:

Lubricant (Mo S2)	Sold as
Molykote 321 (lube coat)	Spray
Molykote spray (powder spray)	Spray
Molykote G Rapid	Spray or compound
Aemasol MO 19P	Spray or compound
Aemasol DIO-sétral 57 N (lube coat)	Spray

3. Grease the clamping screws with a multipurpose grease such as Molykote BR 2.

## 4.7 Shaft-mounted gear units with TorqLOC®

### 4.7.1 Mounting a customer shaft without contact shoulder

Proceed as follows:

1. Clean the customer shaft and the inside of the hollow shaft. Ensure that all traces of grease or oil are removed.
2. Install the stop ring and the bushing on the customer shaft.

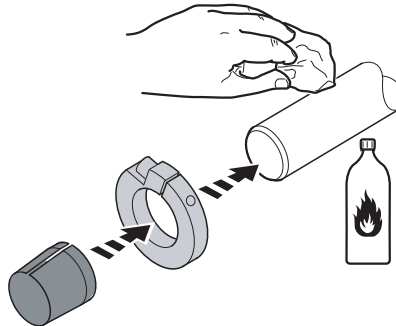

211941003

3. Attach the Torque arm to the drive unit. Note the information in chapter "Torque arm for shaft-mounted gear units" (→ 33).

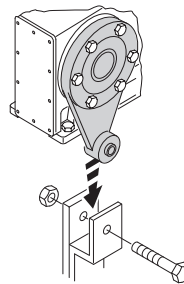

5128549131

4. Apply NOCO® fluid to the bushing. Spread carefully.

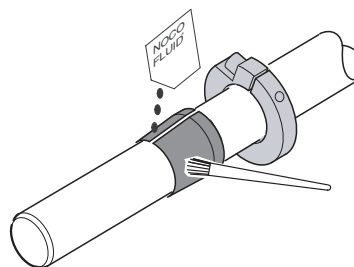

211938827

# 4 Mechanical installation

Shaft-mounted gear unit with TorqLOC

5. Push the gear unit onto the customer shaft.

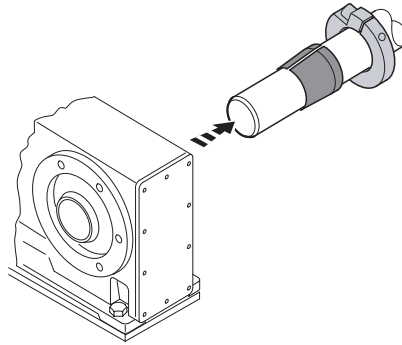

9007199466677643

6. Preassemble the torque arm. Do not firmly tighten the screws.

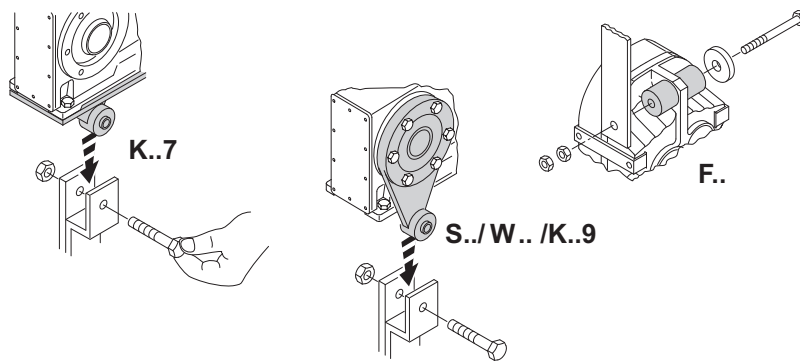

27021597976166155

7. Push the busing into the gear unit up to the stop.

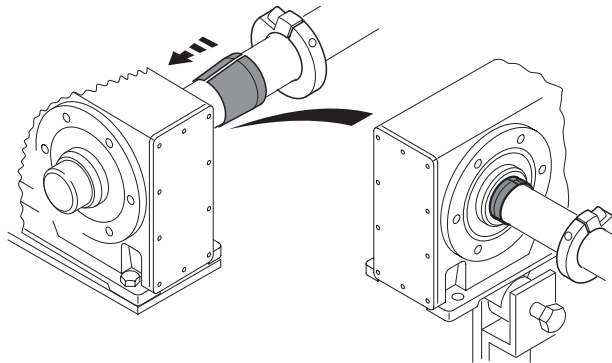

9007199466686347



8. Secure the bushing with the stop ring. Attach the stop ring to the bushing with the respective tightening torque. Refer to the following table for the suitable tightening torque.

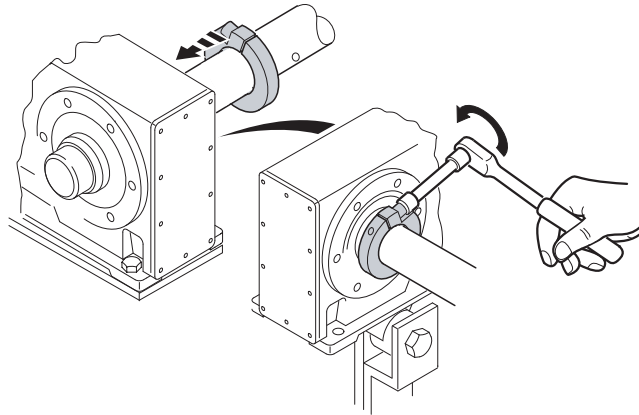

9007199466741899

Type		Tightening torque Nm	
KT/FT	ST/WT	Nickel-plated (standard)	Stainless steel
–	37	10	10
37	47	10	10
39/47	57	10	10
49/57/67	67	25	25
77	77	25	25
87	87	25	25
97	97	25	25
107	–	38	38
127	–	65	65
157	–	150	150

9. Make sure that all screws are loosened and slide the shrink disk onto the hollow shaft.

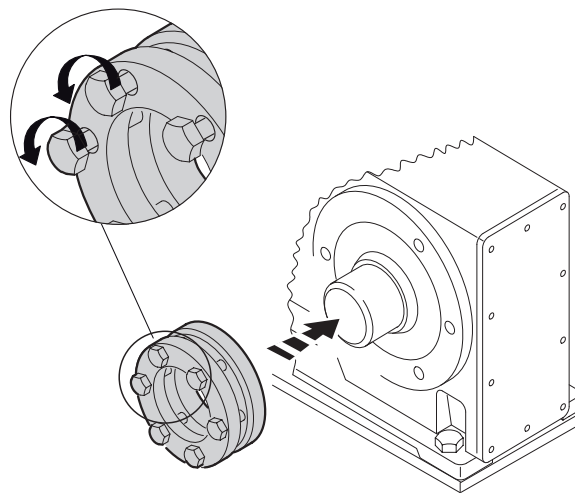

9007199466744075

# 4 Mechanical installation

## Shaft-mounted gear unit with TorqLOC

10. Slide the counter bushing onto the customer shaft and into the hollow shaft.

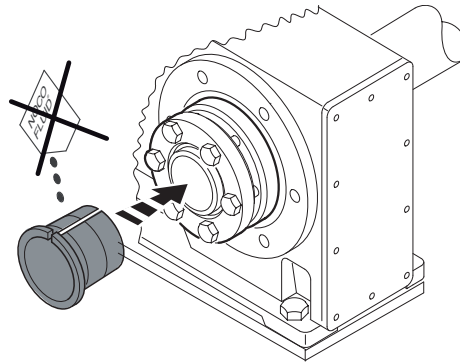

9007199466746251

11. Until the shrink disk is properly seated.

12. Tap lightly on the flange of the counter bushing to ensure that the socket is fitted securely in the hollow shaft.

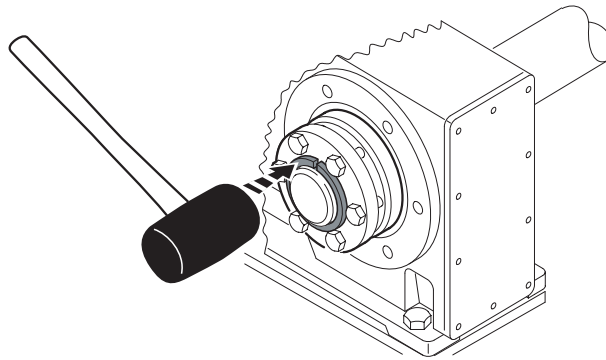

9007199466748427

13. Make sure that the customer shaft is seated in the counter bushing.

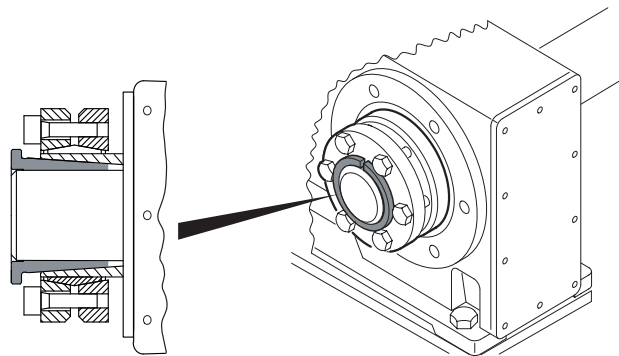

9007199466750603

14. Manually tighten the screws of the shrink disk. Make sure that the outer rings of the shrink disk are plane-parallel.

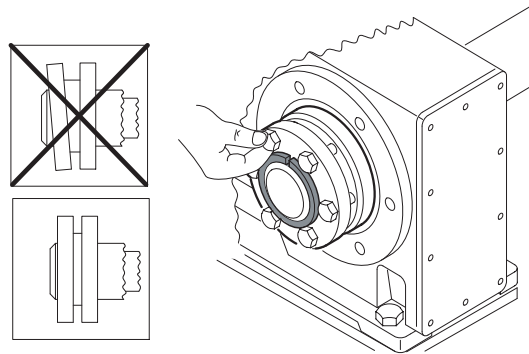

9007199466752779

15. Tighten the clamping screws with the specified tightening torque according to the following table. Tighten the screws by working round several times from one bolt to the next (not in diametrically opposite sequence).

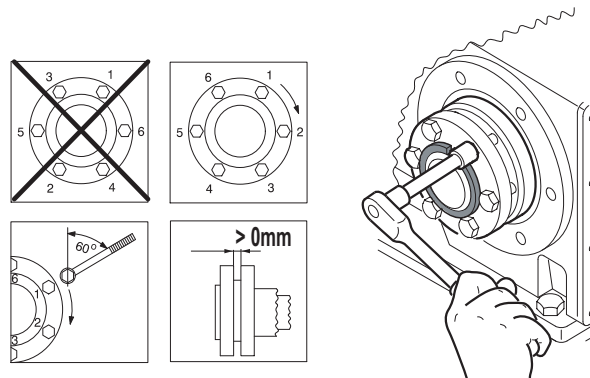

18014398721495947

## INFORMATION



The exact values for the tightening torques are shown on the shrink disk.

Gear unit type				Clamping screws 10.9 ISO 4014 / ISO 4017	Tightening torque Nm	
					Nickel-plated (standard)	Stainless steel
-	-	ST37	WT37	M5	4	5
KT37	FT37	ST47	WT47	M6	12	12
KT39/47/ 49/57/67	FT47/57/67	ST57/67	-	M6	12	12
KT77/87/97	FT77/87/97	ST77/87/97	-	M8	30	30
KT107	FT107	-	-	M10	59	59
KT127	FT127	-	-	M12	100	100
KT157	FT157	-	-	M12	100	100

16. After mounting, make sure the remaining gap "s" between the outer rings of the shrink disk is > 0 mm.

# 4 Mechanical installation

## Shaft-mounted gear unit with TorqLOC

17. Make sure, that the remaining gap between counter bushing and hollow shaft end, as well as between bushing and stop ring is  $> 0$  mm.

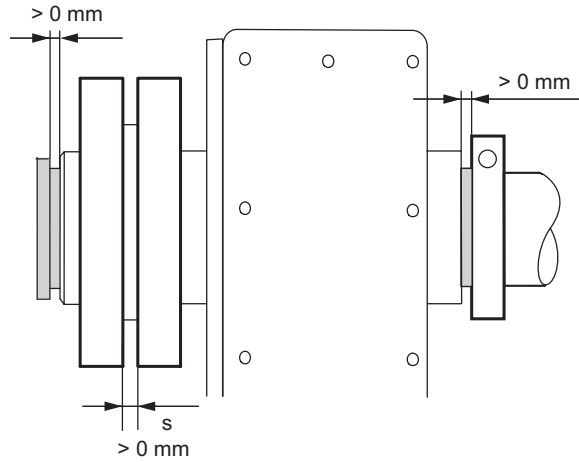

18014400858143115

18. Tighten the torque arm. Note the information in chapter "Torque arm for shaft-mounted gear units" ( $\rightarrow$  33).

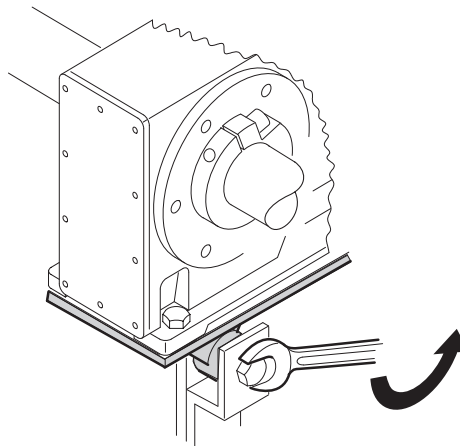

5129142283

### 4.7.2 Installation notes for customer shaft with contact shoulder

1. Clean the customer shaft and the inside of the hollow shaft. Ensure that all traces of grease or oil are removed.
2. Attach the Torque arm to the drive unit. Note the information in chapter "Torque arm for shaft-mounted gear units" ( $\rightarrow$  33).

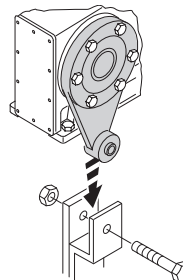

5128549131

21932786/EN – 05/2015

3. Slide the bushing onto the customer shaft.

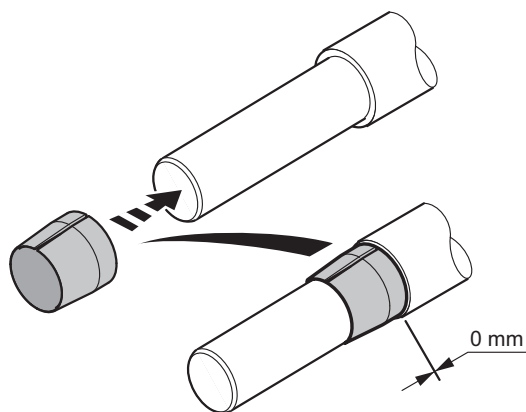

2349377035

4. Apply NOCO® fluid to the bushing. Spread carefully.

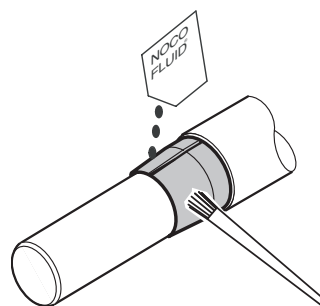

2349367435

5. Push the gear unit onto the customer shaft.

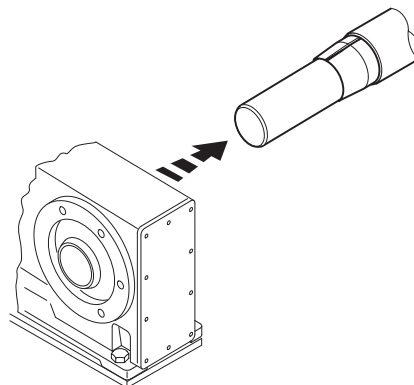

5129650443

# 4 Mechanical installation

Shaft-mounted gear unit with TorqLOC

6. Ensure that all screws have been loosened. Slide the shrink disk onto the hollow shaft.

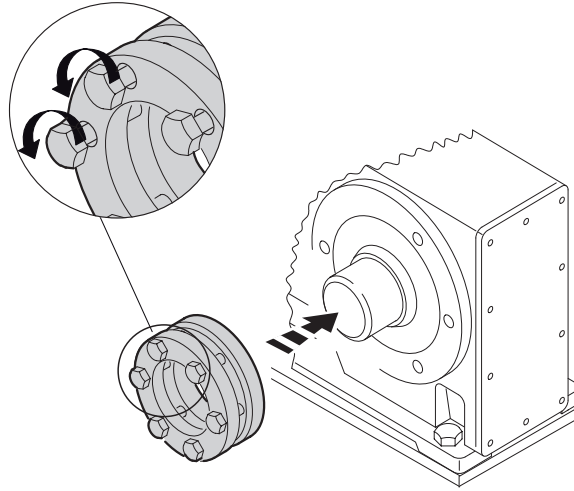

9007199466744075

7. Slide the counter bushing onto the customer shaft and into the hollow shaft.

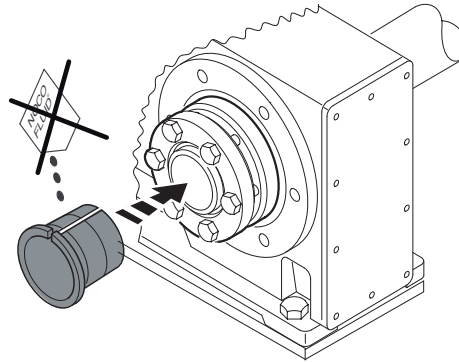

9007199466746251

8. Until the shrink disk is properly seated.
9. Tap lightly on the flange of the counter bushing to ensure that the socket is fitted securely in the hollow shaft.

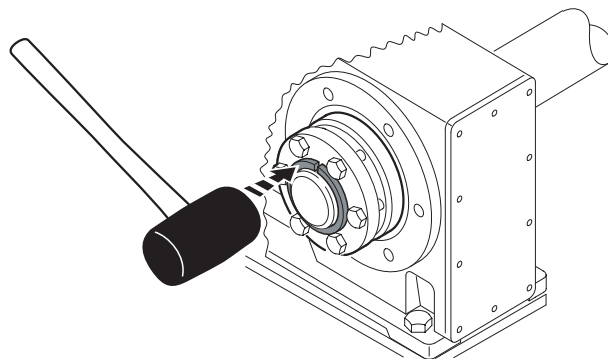

9007199466748427

10. Make sure that the customer shaft is seated in the counter bushing.

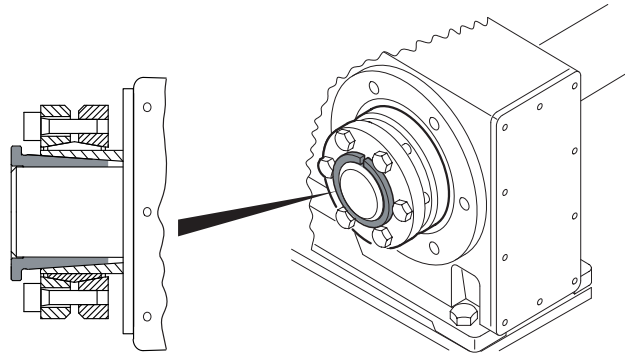

9007199466750603

11. Manually tighten the screws of the shrink disk. Make sure that the outer rings of the shrink disk are plane-parallel.

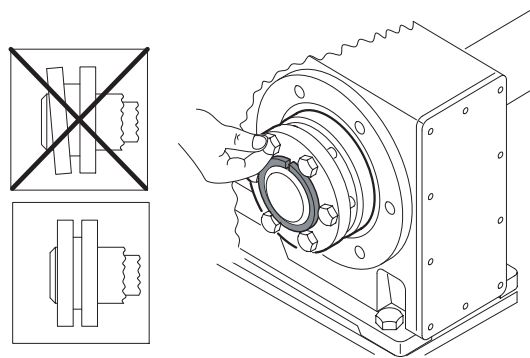

9007199466752779

12. Tighten the clamping screws with the specified tightening torque according to the following table. Tighten the screws by working round several times from one bolt to the next (not in diametrically opposite sequence).

## INFORMATION



The exact values for the tightening torques are shown on the shrink disk.

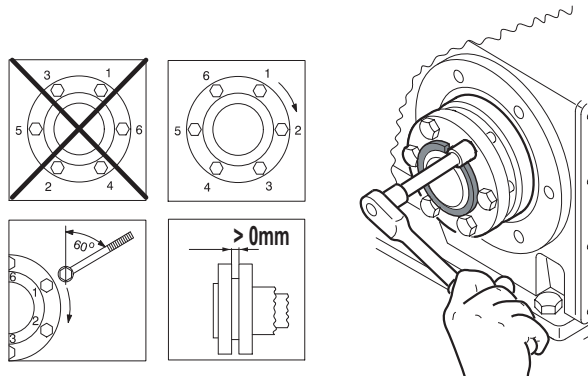

18014398721495947

# 4 Mechanical installation

Shaft-mounted gear unit with TorqLOC

Gear unit type				Clamping screws 10.9 ISO 4014 / ISO 4017	Tightening torque in Nm	
					Nickel-plated (standard)	Stainless steel
-	-	ST37	WT37	M5	4	5
KT37	FT37	ST47	WT47	M6	12	12
KT39/47/49/ 57/67	FT47/57/67	ST57/67	-	M6	12	12
KT77/97	FT77/97	ST77/97	-	M8	30	30
KT107	FT107	-	-	M10	59	59
KT127	FT127	-	-	M12	100	100
KT157	FT157	-	-	M12	100	100

13. After the installation, make sure the remaining gap between the outer rings of the shrink disk is  $> 0$  mm.

14. Make sure, that the remaining gap between counter bushing and hollow shaft end, as well as between bushing and stop ring is  $> 0$  mm.

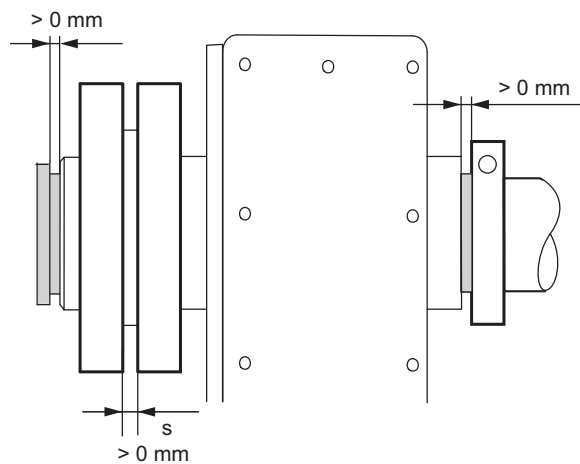

18014400858143115

15. Mount the torque arm and firmly tighten it. Note the information in chapter "Torque arm for shaft-mounted gear units" (→ 33).

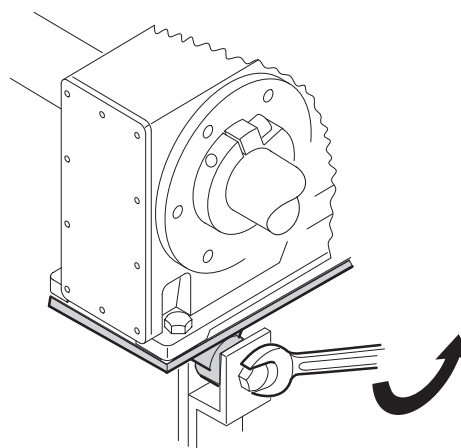

5129142283

21932786/EN – 05/2015



### 4.7.3 Remove the shaft-mounted gear unit

#### ▲ CAUTION



Risk of burns caused by hot surfaces

Severe injuries

- Let the units cool down before working on them.

Proceed as follows:

1. To prevent the outer rings from jamming, loosen the clamping screws for a quarter turn, one after the other.

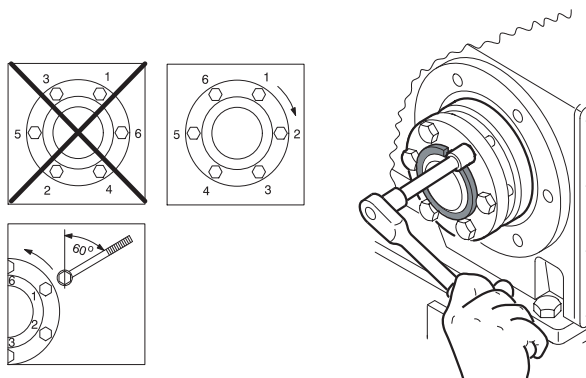

2903644171

2. Unscrew the clamping screws evenly one after the other. Do not remove the clamping screws completely.
3. Dismantle the conical steel bushing. If required, use the outer rings as pullers. Proceed as follows:
  - Remove all the locking screws.
  - Screw the respective number of screws in the tapped holes of the shrink disk.
  - Support the inner ring against the gear unit housing.
  - Pull off the conical steel bushing by tightening the screws.
4. Remove the gear unit from the shaft.

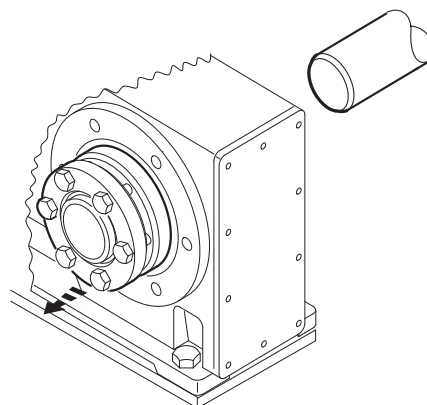

2903780235

5. Remove the shrink disk from the hub.

# 4 Mechanical installation

Shaft-mounted gear unit with TorqLOC

## 4.7.4 Cleaning and lubricating shaft-mounted gear units

There is no need to dismantle removed shrink disks before they are reinstalled.

- If the shrink disk is dirty, clean and lubricate the shrink disk.
- Lubricate the tapered surfaces with one of the following solid lubricants:

Lubricant (Mo S2)	Sold as
Molykote 321 (lube coat)	Spray
Molykote spray (powder spray)	Spray
Molykote G Rapid	Spray or compound
Aemasol MO 19P	Spray or compound
Aemasol DIO-sétral 57 N (lube coat)	Spray

- Grease the clamping screws with a multipurpose grease such as Molykote BR 2.

21932786/EN – 05/2015

## 4.8 Mounting the cover

### ▲ CAUTION



Injury due to assembly work during operation.

Injury

- Before you begin working on the unit, disconnect the motor from the power supply. Safeguard the drive against unintentional restart.

### 4.8.1 Mounting the rotating cover

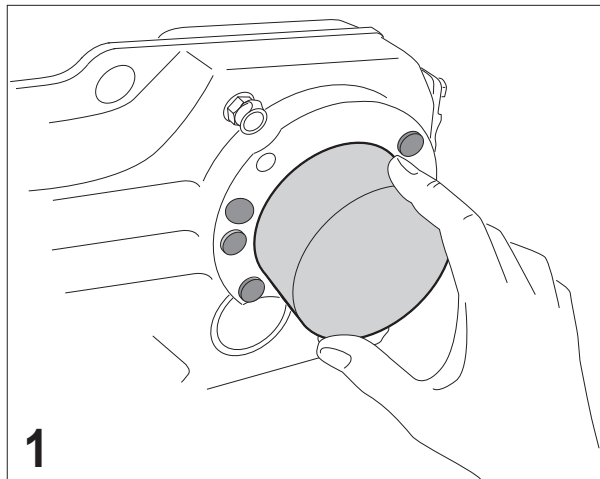

662284299

1. Slide the rotating cover onto the shrink disk until it snaps in.

### 4.8.2 Mounting the fixed cover

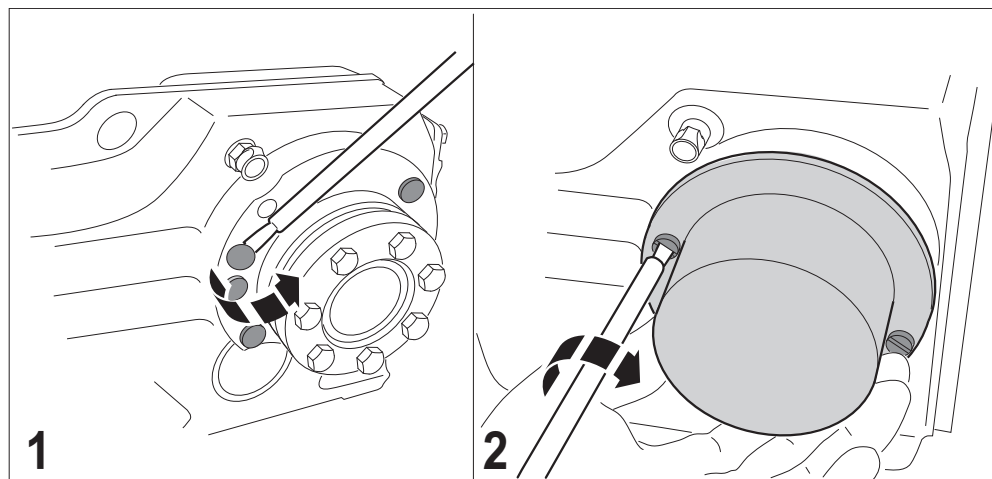

18497547

1. To fasten the cover, remove the plastic plug on the gear unit housing (see figure 1)
2. Use the delivered screws to mount the cover to the gear unit housing (see figure 2).

# 4 Mechanical installation

## Mounting the cover

---

### 4.8.3 Operation without cover

In certain application cases, e.g. with a through-shaft, a cover cannot be installed. The cover is not necessary if the system or unit manufacturer provides corresponding components to guarantee for compliance with the required degree of protection. If this results in additional maintenance, the manufacturer has to describe this in the operating instructions for the system or component.

## 4.9 Coupling of AM adapters

### 4.9.1 Mounting the IEC adapter AM63 – 280/NEMA adapter AM56 – 365

#### NOTICE

Damage to adapter due to ingress of moisture when mounting a motor to the adapter.

Damage to the adapter

- Seal the adapter with an anaerobic fluid seal.

#### INFORMATION



To avoid contact corrosion, SEW-EURODRIVE recommends to apply NOCO® fluid to the motor shaft before mounting the coupling half.

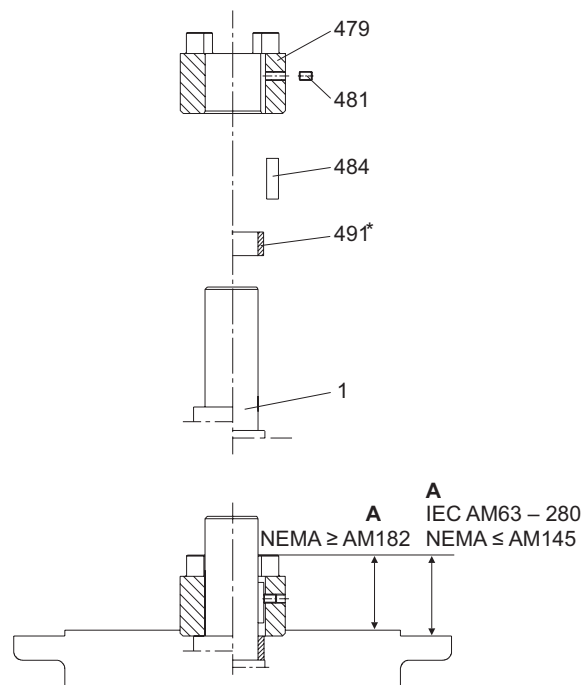

18014398721581963

[1]	Motor shaft	[484]	Key
[479]	Coupling half	[491]	Spacer tube
[481]	Set screw		

Proceed as follows:

1. Clean the motor shaft and flange surfaces of the motor and the adapter.
2. Remove the key from the motor shaft. Replace the key from the motor shaft with the supplied key [484] (not AM63 and AM250).
3. Heat the coupling half [479] to approx. 80 °C – 100 °C and push the coupling half onto the motor shaft. Position as follows:
  - IEC adapter AM63 – 225 until stop at motor shaft shoulder.
  - IEC adapter AM250 – 280 to distance "A". The values for the distance "A" are listed in the following table.
  - NEMA adapter with spacer tube [491] to distance "A." The values for the distance "A" are listed in the following table.

# 4 Mechanical installation

## Coupling of AM adapters

4. Secure the key and coupling half using the set screw [481] on the motor shaft. Refer to the following table for the required tightening torque " $T_A$ ".
5. Check the position of the coupling half. The values for the distance "A" are listed in the following table.
6. Seal the contact surfaces between the adapter and motor using a suitable sealing compound.
7. Mount the motor on the adapter. Ensure that the coupling claws of the adapter shaft are engaged in the plastic cam ring.

IEC AM	63/71	80/90	100/112	132	160/180	200	225	250/280
<b>A</b>	24.5	31.5	41.5	54	76	78.5	93.5	139
<b>T<sub>A</sub></b>	1.5	1.5	4.8	4.8	10	17	17	17
<b>Thread</b>	M4	M4	M6	M6	M8	M10	M10	M10
NEMA AM	56	143/145	182/184	213/215	254/256	284/286	324/326	364/365
<b>A</b>	46	43	55	63.5	78.5	85.5	107	107
<b>T<sub>A</sub></b>	1.5	1.5	4.8	4.8	10	17	17	17
<b>Thread</b>	M4	M4	M6	M6	M8	M10	M10	M10

4.9.2 Permitted loads

**NOTICE**

Damages to gear unit due to impermissibly high loads when mounting a motor.

Damage to gear unit

- Note that the load data specified in the following table are not to be exceeded.

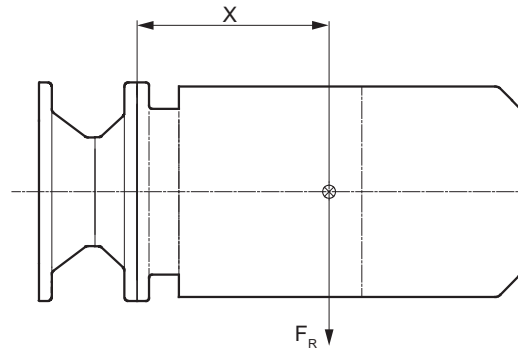

9007199273254411

- ⊗ Motor's center of gravity
- X Distance from adapter flange to the middle of the motor
- $F_R$  Overhung load

Permitted loads for gear unit series R..7, F..7, K..7, K..9, and S..7:

Adapter type		$x^1$ ) in mm	$F_R^1$ ) in N	
IEC	NEMA		IEC adapter	NEMA adapter
AM63/71	AM56	77	530	410
AM80/90	AM143/145	113	420	380
AM100/112	AM182/184	144	2000	1760
AM132 <sup>2)</sup>	AM213/215 <sup>2)</sup>	186	1600	1250
AM132..	AM213/215		4700	3690
AM160/180	AM254/286	251	4600	4340
AM200/225	AM324-AM365	297	5600	5250
AM250/280	-	390	11200	-

1) As the center of gravity distance  $x$  increases, the maximum permitted weight of the attached motor  $F_{R\_max}$  must be reduced linearly. If this center of gravity distance  $x$  is reduced, the maximum permitted weight  $F_{R\_max}$  cannot be increased.

2) Diameter of the adapter output flange: 160 mm

# 4 Mechanical installation

## Coupling of AM adapters

### Permitted loads for gear unit series SPIROPLAN® W37 – W47

Adapter type		x <sup>1)</sup> in mm	F <sub>R</sub> <sup>1)</sup> in N	
IEC	NEMA		IEC adapter	NEMA adapter
AM63/71	AM56	115	140	120
AM80/90	AM143/145	151	270	255

1) As the center of gravity distance  $x$  increases, the maximum permitted weight of the attached motor  $F_{R\_max}$  must be reduced linearly. If this center of gravity distance  $x$  is reduced, the maximum permitted weight  $F_{R\_max}$  cannot be increased.

#### 4.9.3 AM adapter with AM../RS backstop

Check the direction of rotation of the drive prior to assembly or startup. In case of a wrong direction of rotation, contact SEW-EURODRIVE.

The backstop is maintenance-free in operation. Backstops have a minimum lift-off speed depending on the size (see following table).

#### NOTICE

If the speed is below the minimum lift-off speed of the drive, the backstop is subject to wear and heats up.

Possible damage to property.

- In nominal operation the lift-off speed of the drive must not drop below the specified minimum.
- During startup or braking, the lift-off speed of the drive may drop below the minimum levels.

Type	Maximal locking torque of the backstop in Nm	Minimum lift-off speed in 1/min
AM80/90/RS, AM143/145/RS	65	820
AM100/112/RS, AM182/184/RS	425	620
AM132/RS, AM213/215/RS	850	530
AM160/180/RS, AM254/286/RS	1450	480
AM200/225/RS, AM324-365/RS	1950	450
AM250/280/RS	1950	450

21932786/EN – 05/2015



## 4.10 AQ. adapter coupling

### 4.10.1 Mount adapter AQA80 – 190 (with keyway)/Adapter AQH80 – 190 (without keyway)

#### NOTICE

Damage to adapter due to ingress of moisture when mounting a motor to the adapter.

Damage to the adapter

- Seal the adapter with an anaerobic fluid seal.

#### INFORMATION



**For AQA:** To avoid contact corrosion, SEW-EURODRIVE recommends to apply NO-CO® fluid to the motor shaft before mounting the coupling half.

**For AQH:** Using NOCO® fluid is not approved.

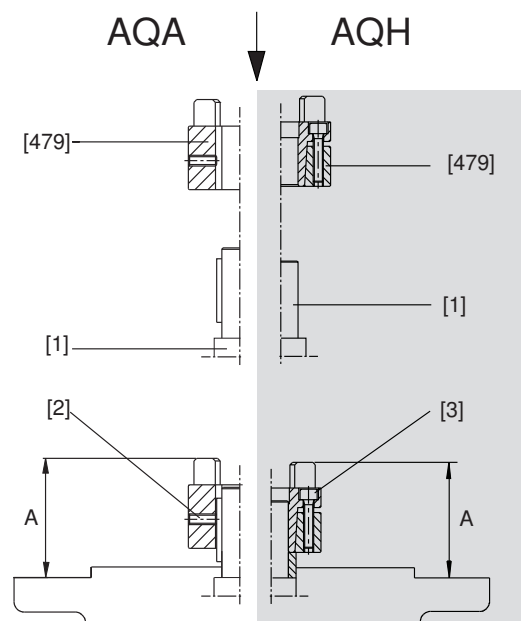

9007199466855947

[1]	Motor shaft	[479]	Coupling half
[2]	Lock washer	[5]	Spacer tube
[3]	Washer	[6]	Customer shaft

Proceed as follows:

1. Clean the motor shaft and flange surfaces of the motor and the adapter.
2. **Design AQH:** Loosen the screws of the coupling half [479] and loosen the conical connection.
3. **AQA/AQH design:** Heat the coupling half to approx. 80 °C – 100 °C and push the coupling half onto the motor shaft until distance "A". The values for the distance "A" are listed in the table in chapter "Setting standards and tightening torques (→ 66)".
4. **Design AQH:** Tighten the screws of the coupling half evenly in diametrically opposite sequence, working around several times. The values for the tightening torque "T<sub>A</sub>" are listed in the table in chapter "Setting standards and tightening torques (→ 66)".

# 4 Mechanical installation

## AQ. adapter coupling

5. **AQA design:** Secure the coupling half using the set screw (see figure).
6. Check the position of the coupling half. The values for the distance "A" are listed in the table in chapter "Setting standards and tightening torques (→ 66)".
7. Mount the motor onto the adapter, making sure that the claws of the two coupling halves engage in each other.
  - ⇒ The force that must be applied when joining the two coupling halves is dissipated after final assembly, so there is no risk of any axial load being applied to adjacent bearings.

### 4.10.2 Setting standards and tightening torques

Type	Coupling size	Distance A mm	Screws		Tightening torque $T_A$ Nm	
			AQA	AQH	AQA	AQH
AQA /AQH 80 /1 /2 /3	19	44.5	M5	6 x M4	2	4.1
AQA /AQH 100 /1 /2		39				
AQA /AQH 100 /3 /4		53				
AQA /AQH 115 /1 /2		62				
AQA /AQH 115 /3	24	62	M5	4 x M5	2	8.5
AQA /AQH 140 /1 /2		62				
AQA /AQH 140 /3 /4	28	74.5	M8	8 x M5	10	8.5
AQA /AQH 160 /1		74.5				
AQA /AQH 190 /1 /2		76.5				
AQA /AQH 190 /3	38	100	M8	8 x M6	10	14

### 4.10.3 Permitted loads



#### ⚠ CAUTION

Impermissibly high loads may occur when mounting a motor.  
Possible damage to property.

- The load data specified in the following table are not to be exceeded.

The following figure shows the permitted force application points for the permitted maximum weights:

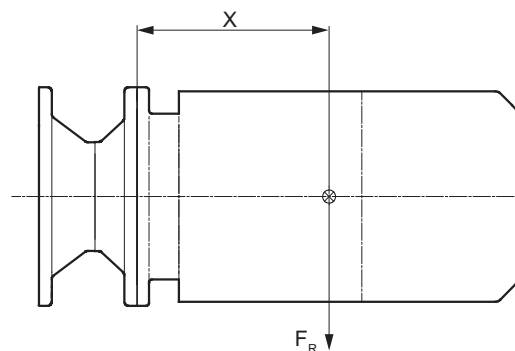

- ⊗ Motor's center of gravity
- X Distance from adapter flange - motor center
- $F_R$  Overhung load

9007199273254411

21932786/EN – 05/2015

Type	x <sup>1)</sup> mm	F <sub>R</sub> <sup>1)</sup> N
<b>AQ80</b>	77	370
<b>AQ100/1/2</b>	113	350
<b>AQ100/3/4</b>	113	315
<b>AQ115</b>	113	300
<b>AQ140/1/2</b>	144	1550
<b>AQ140/3</b>	144	1450
<b>AQ160</b>	144	1450
<b>AQ190/1/2; Flange Ø: 160</b>	186	1250
<b>AQ190/3; Flange Ø: 160</b>	186	1150
<b>AQ190/1/2</b>	186	3750
<b>AQ190/3</b>	186	3400

- 1) Maximum load values for connection screws of strength class 8.8. As the center of gravity distance  $x$  increases, the maximum permitted weight of the attached motor  $F_{R\_max}$  must be reduced linearly. As the center of gravity distance  $x$  decreases, the maximum permitted weight  $F_{R\_max}$  must not be increased.

# 4 Mechanical installation

## EWH adapters

### 4.11 EWH adapters

#### 4.11.1 Adapter EWH01 – 03

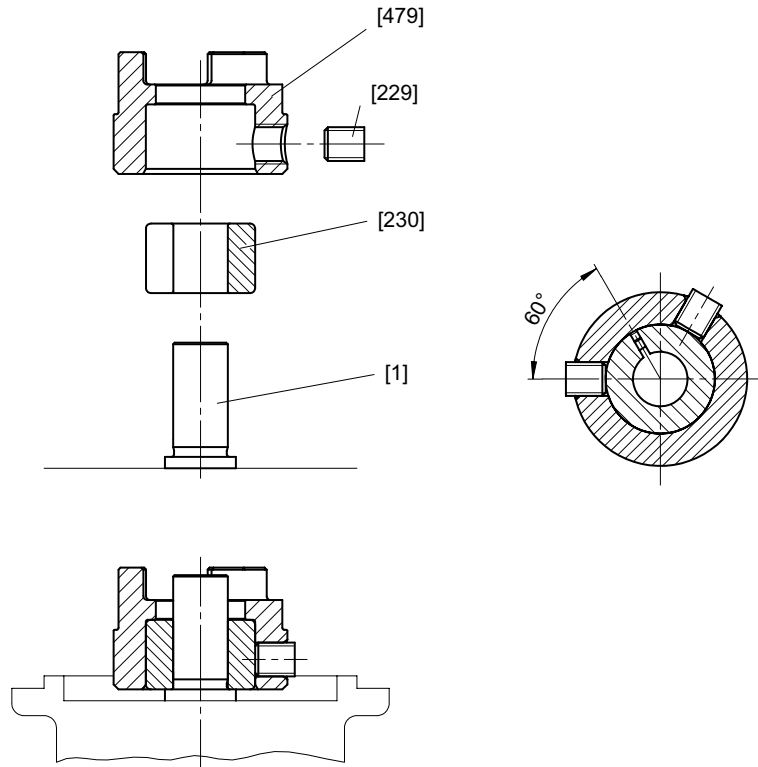

4557485195

[1]	Motor shaft	[230]	Motor shaft sleeve
[229]	Clamping screws	[479]	Coupling half

1. Clean and de-grease the hollow shaft hole of the coupling half [479], the motor shaft sleeve [230], and the motor shaft [1].
2. Insert the motor shaft sleeve [230] into the coupling half [479] so that the slot of the motor shaft sleeve [230] is at a 60° angle to the two clamping screws [229].
3. Push the coupling half [479] on the shoulder of the motor shaft to the stop.
4. Tighten the clamping screws [229] one after the other with a suitable torque wrench, first to 25% of the tightening torque specified in the following table.
5. Tighten the two clamping screws [229] to the full specified tightening torque.

Adapter type	Motor shaft diameter in mm	Number of clamping screws	Tightening torque of the clamping screw in Nm	Wrench size in mm
EWH01	9	2	5.6	3
EWH01	11	2	10	4
EWH02	11; 14; 16	2	10	4
EWH03	11; 14; 16	2	10	4

21932786/EN – 05/2015

4.11.2 Permitted loads

**NOTICE**

Impermissibly high loads may occur when mounting a motor.  
Possible damage to property.

- The load data specified in the following table are not to be exceeded.

The following figure shows the permitted force application points for the permitted maximum weights:

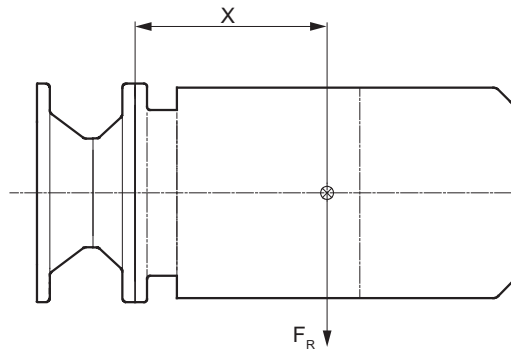

9007199273254411

- ⊗ Motor's center of gravity
  - X Distance from adapter flange to the middle of the motor
- $F_R$  Overhung load

Type	$x^1$ mm	$F_R^1$ N
EWH01	113	40
EWH02	120	56
EWH03	120	56

1) Maximum load values for connection screws of strength class 8.8. As the center of gravity distance  $x$  increases, the maximum permitted weight of the attached motor  $F_{R\_max}$  must be reduced linearly. As the center of gravity distance  $x$  decreases, the maximum permitted weight  $F_{R\_max}$  must not be increased.

# 4 Mechanical installation

## AD Input shaft assembly

### 4.12 AD Input shaft assembly

Observe section "Mounting the input and output components" (→ 31) when installing input components.

#### 4.12.1 Mounting the cover with motor platform AD../P

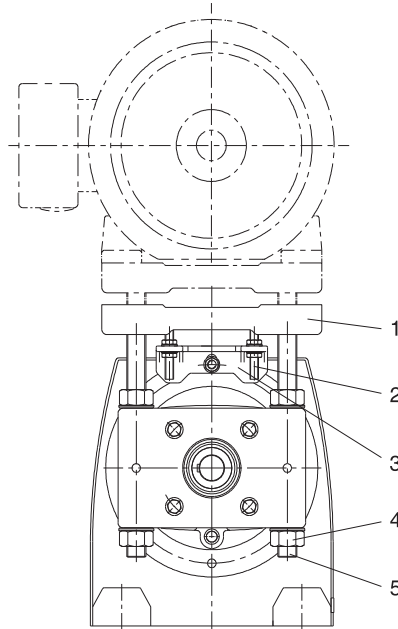

212119307

- |  |                     |
|--|---------------------|
| [1] Motor platform                     | [4] Nut             |
| [2] Threaded bolt (only AD6/P / AD7/P) | [5] Threaded column |
| [3] Support (only AD6/P / AD7/P)       |                     |

To mount the motor and to adjust the motor platform proceed as follows:

1. Set the motor platform [1] to the required mounting position by evenly tightening the adjusting nuts [4].
2. If necessary, remove the eyebolt/lifting eye of the helical gear unit to reach the lowest adjustment position. Touch up any damage to the paint work.
3. Align the motor on the motor platform [1], so that the shaft ends are in line. Attach the motor.
4. Mount the drive component onto the input side shaft end and the motor shaft.
5. Align drive component, shaft end and motor shaft. If necessary correct the motor position again.
6. Put on the traction elements (V-belt, chain, etc.) and apply a preload by evenly adjusting the motor platform [1]. Do not stress the motor platform and the columns against each other when doing this.
7. To fasten the threaded columns [5] tighten the nuts [4] that are not used for adjustment.

21932786/EN – 05/2015

#### 4.12.2 Special aspects of AD6/P and AD7/P

Proceed as follows:

1. Unscrew the nuts on the threaded bolts [2] before adjustment, to allow the threaded bolts [2] to move axially in the support [3] without restriction.
2. Only tighten the nuts, when the final adjustment position is reached.

### INFORMATION



Do not adjust the motor platform [1] via the support [3].

#### 4.12.3 AD../ZR input shaft assembly with centering shoulder

Mounting applications on the input shaft assembly with centering shoulder.

1. Prepare screws of a suitable length for attaching the application. The following figure shows the screw length  $l = t + a$ . **Round off the result to the next smaller standard length.**

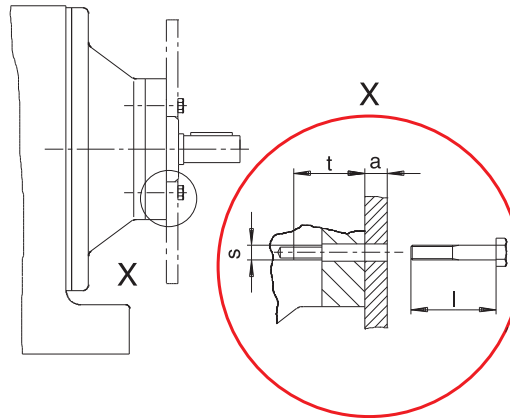

9007199466862475

- a Thickness of the application      s Retaining thread (see table)  
t Screw-in depth (see table)

2. Remove the retaining screw from the centering shoulder.
3. Clean the contact surface and the centering shoulder.
4. Clean the threads of the new screws and apply a threadlocker compound (e.g. Loctite® 243) to the first few threads.
5. Place the application on the centering shoulder. Tighten the retaining screws with the specified tightening torque "T<sub>A</sub>" (see table).

Type	Screw-in depth t mm	Retaining thread s	Tightening torque T <sub>A</sub> for connection screws of strength class 8.8 Nm
AD2/ZR	25.5	M8	25
AD3/ZR	31.5	M10	48
AD4/ZR	36	M12	86
AD5/ZR	44	M12	86
AD6/ZR	48.5	M16	210

# 4 Mechanical installation

AD Input shaft assembly

Type	Screw-in depth t mm	Retaining thread s	Tightening torque $T_A$ for connection screws of strength class 8.8 Nm
AD7/ZR	49	M20	410
AD8/ZR	42	M12	86

## Permitted loads

### NOTICE

Damage to gear unit due to impermissibly high loads when mounting a motor.

Damage to gear unit

- Note that the load data specified in the following table are not to be exceeded.

The following figure shows the permitted force application points for the permitted maximum weights:

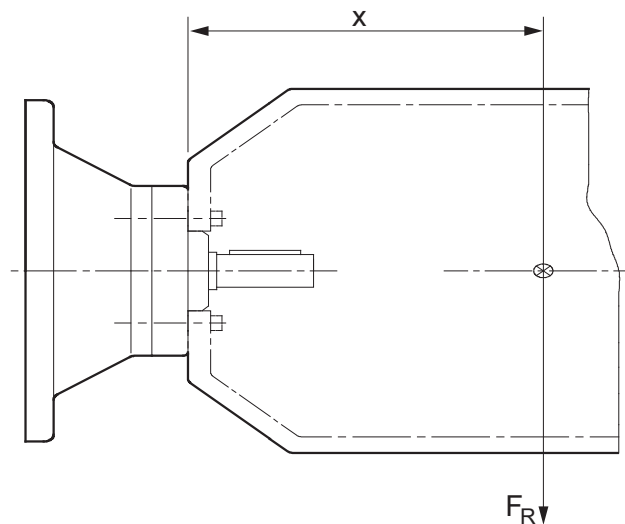

9007199466864651

- ⊗ Motor's center of gravity  $F_R$  Overhung load  
 X Distance from adapter flange to the middle of the motor

Type	$x^1$ mm	$F_R^1$ N
AD2/ZR	193	330
AD3/ZR	274	1400
AD4/ZR <sup>2)</sup>	361	1120
AD4/ZR		3300
AD5/ZR	487	3200
AD6/ZR	567	3900
AD7/ZR	663	10000

21932786/EN – 05/2015



Type	x <sup>1)</sup> mm	F <sub>R</sub> <sup>1)</sup> N
AD8/ZR	516	4300

- 1) Maximum load values for connection screws of strength class 8.8. As the center of gravity distance x increases, the maximum permitted weight of the attached motor  $F_{R_{max}}$  must be reduced linearly. As the center of gravity distance x decreases, the maximum permitted weight  $F_{R_{max}}$  must not be increased.
- 2) Diameter of the adapter output flange: 160 mm

#### 4.12.4 Cover with backstop AD../RS

Check the direction of rotation of the drive prior to assembly or startup. In case of a wrong direction of rotation, contact SEW-EURODRIVE.

The backstop is maintenance-free in operation. Backstops have a minimum lift-off speed depending on the size (see following table).

#### NOTICE

If the speed is below the minimum lift-off speed of the drive, the backstop is subject to wear and heats up.

Possible damage to property.

- In nominal operation the lift-off speed of the drive must not drop below the specified minimum.
- During startup or braking, the lift-off speed of the drive may drop below the minimum levels.

Type	Maximum locking torque of the backstop Nm	Minimum lift-off speed 1/min
AD2/RS	65	820
AD3/RS	425	620
AD4/RS	850	530
AD5/RS	1450	480
AD6/RS	1950	450
AD7/RS	1950	450
AD8/RS	1950	450

### 4.13 Accessory equipment

#### 4.13.1 AR.. and AT.. centrifugal and friction couplings

##### AR.. friction coupling

Drives with a slip clutch consist of a standard gear unit and motor/variable speed gearmotor with an adapter installed between them. This adapter accommodates the slip clutch. In gearmotors with a double gear unit, the slip clutch may be located between the first and second gear units. On delivery, the slip torque is set individually according to the drive selection.

The following figure shows a drive with slip clutch and W speed monitor:

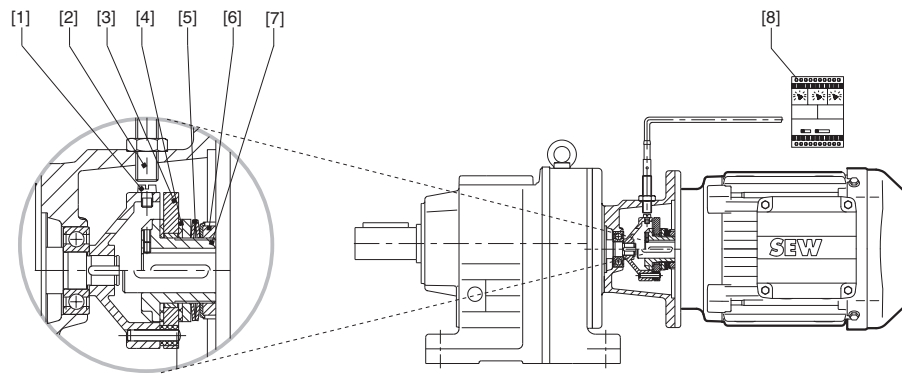

1901048587

[1] Trip cam	[4] Friction lining	[7] Friction hub
[2] Incremental encoder	[5] Cup spring	[8] Speed monitor
[3] Driving disk	[6] Slotted nut	

##### W speed monitor:

The speed monitor is used with constant-speed gearmotors and is connected to the incremental encoder in the adapter.

##### WS slip monitor:

The slip monitor is used with the following components:

- Speed-controlled motors with speed sensor
- VARIGEAR® variable-speed gear units

## INFORMATION



For further information about the AR.. coupling, refer to the "Start-up coupling and slip clutch AR.. and AT.." operating instructions.

##### AT.. hydraulic centrifugal coupling

Hydraulic centrifugal couplings are fluid couplings based on the Föttinger principle. They consist of 2 hinged hemispheres with blades separated by a tight gap.

The applied torque is transmitted by the inertial force of the streaming fluid. This fluid circulates within a closed circuit, between the pump wheel (primary side) [12] on the driving shaft (motor shaft) and the turbine wheel (secondary side) [9] on the driven shaft (gear unit input shaft).

The following figure shows the structure of a drive with hydraulic centrifugal coupling:

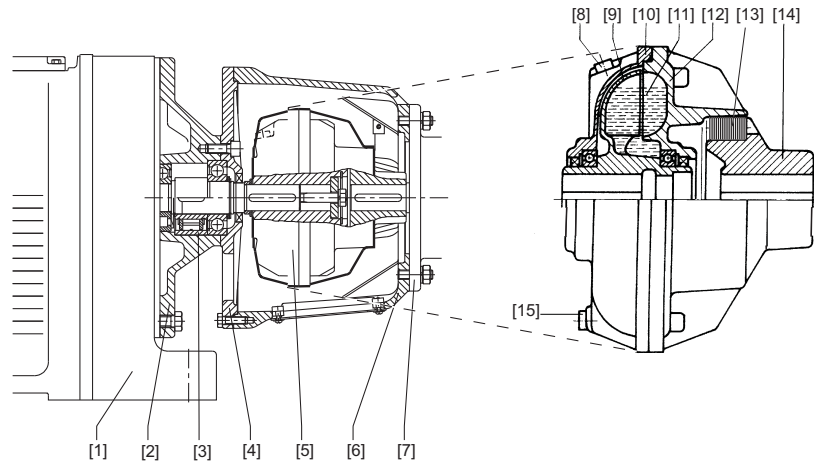

9007201155884683

- |                           |                               |                                      |
|---------------------------|-------------------------------|--------------------------------------|
| [1] Gear unit             | [6] Extended housing complete | [11] Operating fluid (hydraulic oil) |
| [2] Basic flange complete | [7] Motor                     | [12] Pump wheel                      |
| [3] Backstop (optional)   | [8] Filler plug               | [13] Elastic components              |
| [4] Intermediate flange   | [9] Turbine wheel             | [14] Flexible connection coupling    |

## INFORMATION



For detailed information about the AT.. coupling, refer to the "Start-up coupling and slip clutch AR.. and AT.." operating instructions.

### 4.13.2 Diagnostic units DUV and DUO

#### Diagnostic unit DUV

The DUV30A diagnostic unit evaluates vibration signals using frequency analysis methods. A micromechanical acceleration sensor is used in the unit. Data can be recorded, processed and evaluated locally without any expert knowledge.

The DUV30A diagnostic unit is suitable for early recognition of rolling bearing damage or imbalance. The continuous monitoring function represents a reliable and cost-effective solution compared to intermittent methods.

The DUV30A has been designed as a combined sensor that can be used as normal-speed unit or slow-speed unit. The only difference is the measuring time in the firmware and the resulting frequency range.

The following figure depicts the diagnostic unit DUV30A:

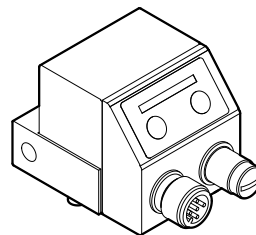

4428331403

### INFORMATION



For further information on the evaluation unit, refer to the manual "DUV30A Diagnostic Unit".

#### Diagnostic unit DUO

DUO10A comprises a diagnostic unit and a temperature sensor. The temperature sensor (PT100 or PT1000 resistance sensor) is positioned in the gear unit oil to record the oil's temperature. The diagnostic unit uses the oil temperature values to calculate the remaining service life of the oil.

The diagnostic unit continuously records the gear unit temperature and calculates the remaining service life for the selected oil type immediately. For this purpose, the diagnostic unit must be supplied with a 24 V voltage supply. Times when the diagnostic unit is switched off are not included in the forecast.

The following figure shows the DUO10A diagnostic unit:

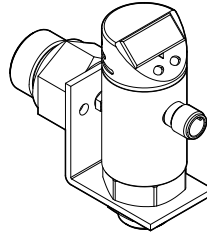

4719800843

### INFORMATION



For further information on the evaluation unit, refer to the manual "DUV30A Diagnostic Unit".

#### 4.13.3 Gear unit heater for gear unit series R..7, F..7, and K..7

An oil heating can be required in order to allow for a smooth startup in the event of a cold start at low ambient temperatures. An oil heating is available with an external or an integrated thermostat depending on the gear unit design.

The heater is screwed into the gear unit housing and is controlled via a thermostat. The limit temperature of the thermostat below which the oil must be heated, is set depending on the respective lubricant.

The following figure shows a gear unit with heater and external thermostat:

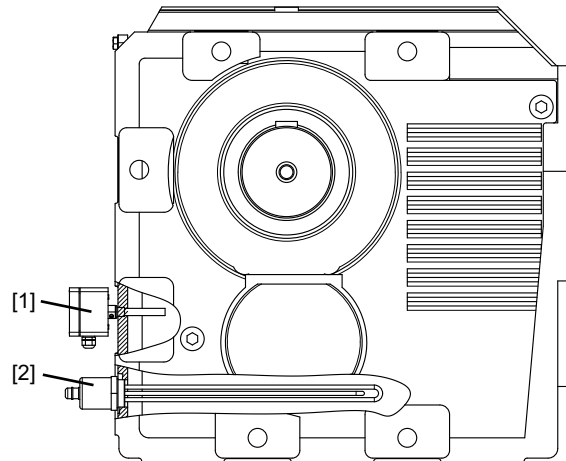

2060553483

[1] Thermostat

[2] Heater

### INFORMATION



For further information regarding gear unit heaters, refer to the addendum "Gear unit heaters for gear unit series R..7, F..7 and K..7" to the operating instructions "Gear unit series R..7, F..7, K..7, K..9, S..7, SPIROPLAN® W".

### 4.13.4 Flange coupling

Flange couplings [1] are rigid couplings for connecting 2 shafts [2].

Flange couplings are suitable for operation in both directions of rotation, but cannot compensate any shaft misalignments.

Torque between shaft and coupling is transmitted via a cylindrical interference fit. The two coupling halves are mounted together at the flanges. The couplings are equipped with several disassembly bores [3] for removing the interference fit hydraulically.

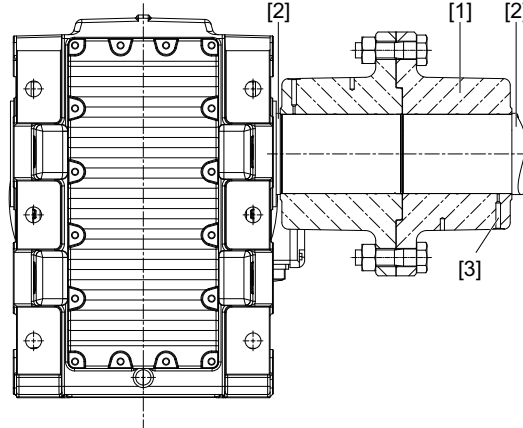

27021601961007627

[1] Rigid flange coupling  
[2] Customer and gear shaft

[3] Disassembly bores

### INFORMATION



For detailed information about the rigid flange coupling, refer to the "Gear Unit Series R..7, F..7, K..7, S..7, and SPIROPLAN® W – Rigid flange coupling" addendum to the operating instructions.

#### 4.13.5 Regreasing the labyrinth seal

Labyrinth seals are used to protect the oil seal in case of very high dust load or other abrasive substances.

#### Output shaft

The following figure shows an example of a regreasable radial labyrinth seal (taconite).

- Single oil seal with radial labyrinth seal
- Used in **very dusty** environments with abrasive particles

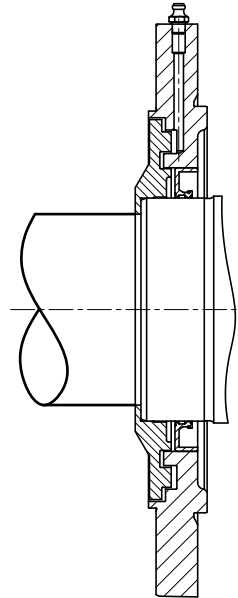

9007204406135947

### INFORMATION



The gear shaft must rotate during relubrication.

#### Position of greasing points

Regreasable sealing systems are usually equipped with taper greasing nipples according to DIN 71412 A. Relubrication must be carried out at regular intervals. The greasing points are located near the output shaft, see following figure:

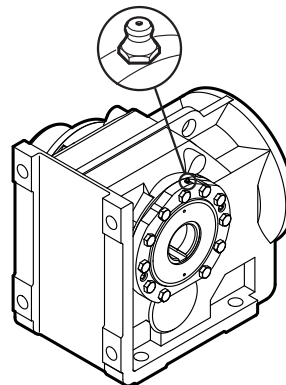

4986644747

# 4 Mechanical installation

Accessory equipment

## Refilling grease

Regreasable sealing systems can be refilled with lubricating grease. Use moderate pressure to force grease into each lubrication point until new grease leaks out of the sealing gap.

Used grease, including contaminants and sand, is in this way pressed out of the sealing gap.

## INFORMATION



Immediately remove the old grease that leaked out.

## Inspection and maintenance intervals



Observe the following inspection and maintenance intervals for the regreasing of labyrinth seals:

Time interval	What to do?
Every 3000 operating hours, at least every 6 months	Fill regreasable sealing systems with grease.

## Technical data

### Sealing and rolling bearing grease

The table shows the greases recommended by SEW-EURODRIVE for an operating temperature of -40 °C to +80 °C:

Manufacturer	Grease
Fuchs	Renolit CX TOM 15 OEM
Aral 	Aral Eural Grease EP2
Aral 	Aral Aralube BAB EP2

## INFORMATION



If a customer wants to use a grease that is not listed in the above table, the customer has to make sure that it is suitable for the intended application.



**4.13.6 Oil drain valve**

The gear unit is equipped with an oil drain plug as standard. An oil drain valve can optionally be installed, that enables attaching a drain pipe for changing the gear unit oil.

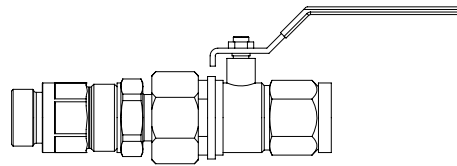

4984750475

**4.13.7 Oil expansion tank**

The oil expansion tank equalizes oil volume fluctuations in the system due to changing temperatures. If the gear unit temperature rises, part of the expanding oil volume can flow into the oil expansion tank. If the gear unit temperature falls again, the oil flows back into the system. Thus the gear unit is completely filled with oil in all operating states.

The following figure shows an example of a gearmotor in mounting position M4:

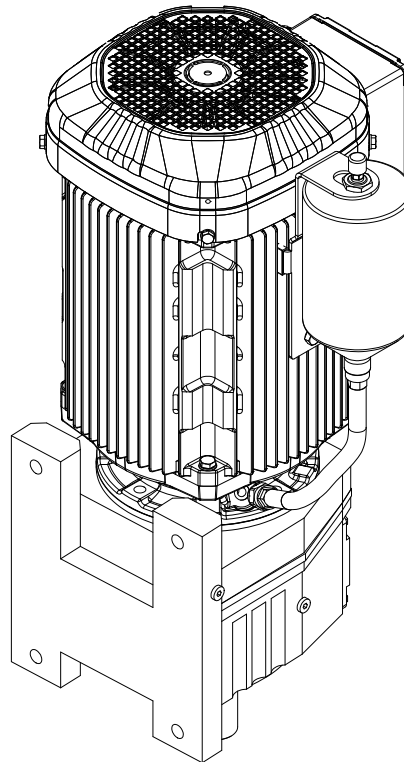

4986667147

# 4 Mechanical installation

## Accessory equipment

### 4.13.8 Oil-air cooler for splash lubrication /OAC

If the thermal rating of the naturally cooled gear unit is not sufficient, an oil-air cooling system can be used.

The cooling system is delivered without electrical wiring and piping as a complete unit on a base frame for separate installation.

The standard scope of delivery of the cooling system includes:

- Pump with directly mounted asynchronous motor
- Oil-air heat exchanger
- Temperature switch with 2 switching points

SEW-EURODRIVE uses oil-air cooling systems for standard gear units in sizes OAC 005 and OAC 010.

The following figure shows an example of a standard parallel-shaft helical gear unit next to an oil-air cooler.

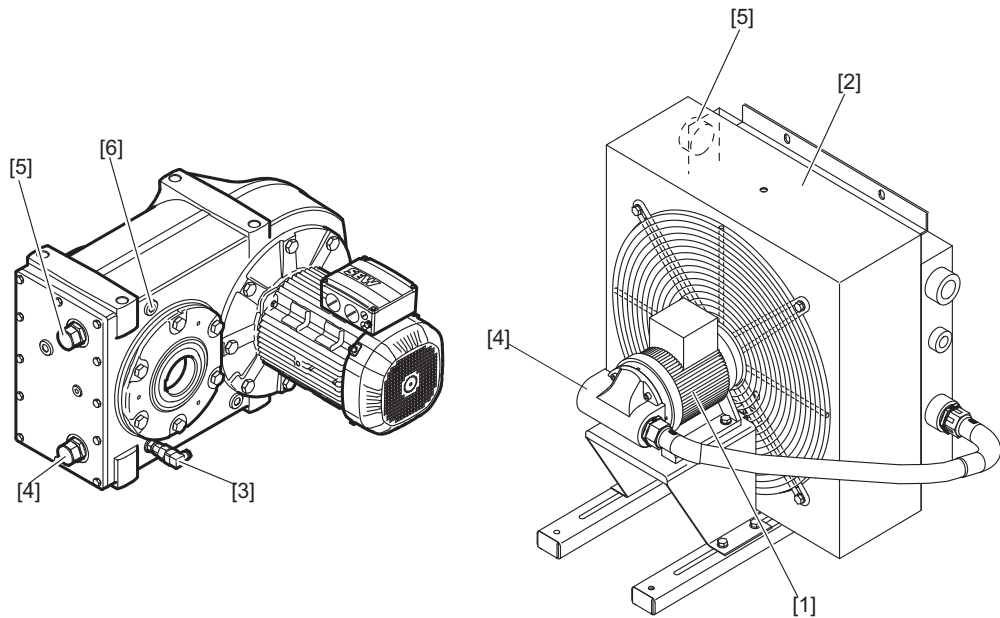

9007208235792395

- |     |  |     |                                       |
|-----|--|-----|---------------------------------------|
| [1] | Motor for pump and fan                     | [4] | Suction pipe connections              |
| [2] | Oil-air heat exchanger                     | [5] | Pressure pipe connections             |
| [3] | Temperature switch with 2 switching points | [6] | Option: Oil expansion tank connection |

### INFORMATION



For more information on the cooling system, refer to the addendum to the operating instructions "Gear unit series R..7, F..7, K..7, K..9, S..7 and SPIROPLAN® W: Oil-air cooler for splash lubrication /OAC".

## 5 Startup



### ▲ CAUTION

Damage to the gear unit due to improper startup.

Possible damage to property.

- Observe the following notes.
- 
- Before startup, always check that the oil level is correct. Refer to the unit's nameplate for lubricant fill quantities.
  - The oil level plugs and oil drain plugs, as well as the breather plugs and breather valves must be freely accessible.
  - The most important technical data is provided on the nameplate. Additional data relevant for operation is available in drawings and the order confirmation.
  - After having gear unit setup, ensure that all retaining screws are tight.
  - Make sure that the alignment has not changed after tightening the mounting elements.
  - Prior to startup, ensure that rotating shafts as well as couplings are equipped with suitable protective covers.
  - If the gear unit has an oil sight glass to monitor the oil level, the oil sight glass must be protected against damage.
  - It is essential that there is no open fire or risk of sparks when working on the gear unit.
  - Protect the gear unit from falling objects.
  - Remove transport protection prior to startup.
  - Strictly observe the safety notes in the individual chapters.

### 5.1 Checking the oil level

Before startup, make sure that the oil level corresponds to the mounting position. Observe section "Checking the oil level and changing the oil" (→ 95).

If the gear unit is equipped with an oil sight glass, you can also determine the oil level at the oil sight glass.

### NOTICE

Damage to the gear unit due to oil leaking from the damaged oil sight glass.

Possible damage to the unit.

- Attach a protective device to prevent the oil sight glass from being damaged by mechanical impacts.

- 
1. Observe the notes in chapter "General information (→ 88)".
  2. Check the oil level at the oil sight glass according to the following figure:

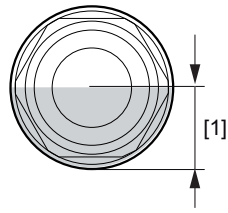

4158756363

[1] The oil level must be within this range.

3. Proceed as follows if the oil level is too low:

- Open the respective oil fill plug, see chapter "Inspection/maintenance for the gear unit (→ 95)".
- Fill in new oil of the same type through the oil fill plug up to the mark.
- Screw in the oil fill plug.

Before startup, make sure that the oil level corresponds to the mounting position. Observe section "Checking the oil level and changing the oil" (→ 95).

## 5.2 Pseudo-leakage at shaft seals

Due to their operating principle, seals between moving surfaces at shaft passages cannot be completely tight, as a lubricant film must form during operation. The lubricant film between shaft and sealing lip keeps the development of heat and wear on the sealing system to a minimum and ensures the intended service life. The optimum sealing properties are only achieved after the run-in phase.

## 5.3 Helical-worm gear units and SPIROPLAN® W gear units

### 5.3.1 Run-in period

SPIROPLAN® and helical-worm gear units require a run-in period of at least 48 h before reaching their maximum efficiency. A separate run-in period applies for each direction of rotation if the gear unit is operated in both directions of rotation. The table shows the average power reduction during the run-in period.

#### Helical-worm gear units

	Worm	
	i range	$\eta$ reduction
<b>1-start</b>	Approx. 50 ... 280	About 12 %
<b>2-start</b>	Approx. 20 ... 75	About 6 %
<b>3-start</b>	Approx. 20 ... 90	About 3 %
<b>4-start</b>	-	-
<b>5-start</b>	Approx. 6 ... 25	About 3 %
<b>6-start</b>	Approx. 7 ... 25	About 2 %

#### SPIROPLAN® gear units

W10 / W20 / W30		W37 / W47	
i range	$\eta$ reduction	i range	$\eta$ reduction
Approx. 35 ... 75	About 15 %		
Approx. 20 ... 35	About 10 %		
Approx. 10 ... 20	About 8 %	Approx. 30...70	About 8 %
About 8	About 5 %	Approx. 10 ... 30	About 5%
About 6	About 3 %	Approx. 3...10	About 3%

## 5.4 Helical/parallel shaft helical/helical-bevel gear units

No special startup instructions are required for helical, parallel shaft helical and helical-bevel gear units providing the gear units have been installed in accordance with section "Mechanical Installation" (→ 22).

## 5.5 Gear units with backstop

### NOTICE

Operating the motor in the blocking direction could destroy the backstop.

Possible damage to property

- Do not start up the motor in the blocking direction. Before motor startup, make sure the current supply of the motor for the direction of rotation is connected accordingly.
- For control purposes, operation in blocking direction with half the output torque is permitted once.

The purpose of a backstop is to prevent unwanted directions of rotation. During operation, the backstop permits rotation only in the specified direction.

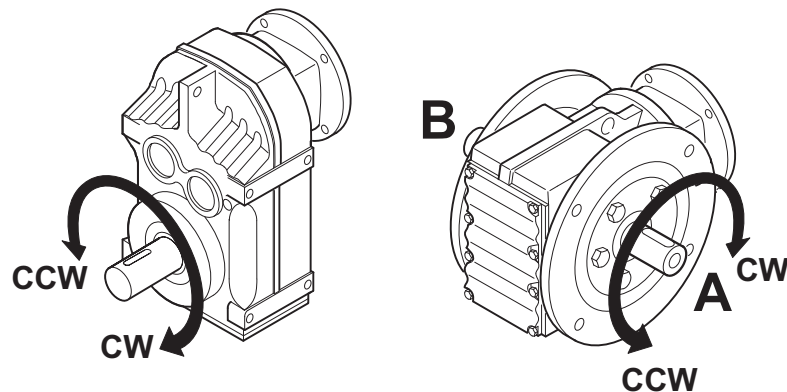

659173899

The direction of rotation is specified as viewed onto the output shaft (LSS):

- CW rotation
- CCW rotation

The permitted direction of rotation is indicated on the housing.

## 5.6 Components made of elastomers with fluorocarbon rubber



### ▲ CAUTION

Health risk due to dangerous gases, vapors, and residue created by heating fluorocarbon rubber to  $> 200\text{ }^{\circ}\text{C}$ .

Damage to health.

- Make sure that components made of fluorocarbon rubber are not exposed to temperatures  $> 200\text{ }^{\circ}\text{C}$ . Remove the components, if necessary.
- Avoid inhaling fluorocarbon rubber gases and vapors as well as skin and eye contact.
- Avoid contact with the cooled-down fluorocarbon rubber, as dangerous residue has formed it was heated.

Under normal operating conditions and at temperatures up to 200 °C, fluorocarbon rubber is very stable and safe. However, when heated to more than 300 °C, e.g. by fire or the flame of a cutting torch, fluorocarbon rubber forms harmful gases and vapors as well as residue.

The following components of R..7, F..7, K..7, K..9, S..7, and SPIROPLAN® W gear units can contain elastomers made of fluorocarbon rubber:

- Oil seals
- Breather valve
- Screw plugs

The user is responsible for safe handling during the service life including eco-friendly disposal.

SEW-EURODRIVE is not responsible for damage caused by improper handling.

## 6 Inspection/maintenance

### 6.1 General information

Observe the following notes regarding inspection/maintenance work at the gear unit:



#### ▲ WARNING

Risk of crushing if the drive starts up unintentionally.

Severe or fatal injuries.

- Disconnect the gearmotor from the power supply before you start working on the unit.
- Prevent the gearmotor from starting up unintentionally (for example, by locking the key switch or removing the fuses from the current supply).



#### ▲ WARNING

Risk of injury if preloaded shaft connections are loosened.

Severe or fatal injuries.

- Before releasing any shaft connections, make sure there is no active torsional torque present that could lead to tension within the system.



#### ▲ WARNING

Risk of burns due to hot gear unit and hot gear unit oil.

Severe injuries

- Let the gear unit cool down before you start working on it.
- Carefully remove the oil level plug and the oil drain plug.

#### NOTICE

Loss of lubricant qualities due to filling of wrong gear unit oil.

Damage to the gear unit

- Do not mix different synthetic lubricants and do not mix synthetic and mineral lubricants.
- As standard lubricant use mineral oil.

#### NOTICE

Ingression of water at the sealing lip of the oil seal due to cleaning the gear unit with a high-pressure cleaning device.

Damage to oil seals

- Do not clean the variable-speed gear unit with a high-pressure cleaning device.



**NOTICE**

Damage to gear unit due to ingress of foreign objects during maintenance and inspection work.

Destruction of the gear unit.

- Prevent foreign particles from entering into the gear unit during maintenance and inspection work.

**NOTICE**

Damage to gear unit due to improper inspection and maintenance work.

Damage to the gear unit

- It is important that you observe the notes in this chapter.

**INFORMATION**

- Maintain the inspection and maintenance intervals. This is necessary to ensure operational safety.
- The position of the oil level plug, oil drain plug and the breather valve depends on the mounting position. Refer to the mounting position sheets in chapter "Mounting positions".
- Perform safety and functional check following all maintenance and repair work.

## 6.2 Wearing parts

### Gearing

If the SEW-EURODRIVE design criteria and the intervals for inspection and maintenance are observed, the gearing components are wear-free after the run-in period. The worm gearing is an exception from this for constructional reasons. The amount of material abrasion on the worm gear tooth flanks varies depending on the operating conditions. The main influencing factors are:

- Speed
- Load
- Operating temperature
- Lubricant (type, viscosity, additives, pollution)
- Operating frequency

For information on the worm gearing service life under certain operating conditions, contact SEW-EURODRIVE.

### Rolling bearing

Rolling bearing, adapter and input shaft assembly have a limited service life, even under ideal operating conditions. This nominal bearing service life is a solely statistical value. The actual service life of an individual bearing may deviate greatly from this value. The main influencing factors are:

- Speed
- Equivalent bearing load
- Operating temperature
- Lubricant (type, viscosity, additives, pollution)
- Lubricant supply of the bearing
- Misalignment under operating load

Therefore the rolling bearings must be inspected regularly. Note the respective inspection and maintenance intervals in chapters Inspection/maintenance intervals (→ [92](#)), Lubricant change intervals (→ [93](#)), Maintenance of AL/AM/AQ./EWH adapter (→ [93](#)) and AD input shaft assembly maintenance (→ [94](#)).

For information on the nominal bearing service life under certain operating conditions, contact SEW-EURODRIVE.

### Lubricants

Lubricants are subject to aging. Their service life is limited depending on the load conditions.

The service life significantly depends on the oil operating temperature. The dependency of lubricant change intervals and operating temperature is depicted in the figure in chapter Lubricant change intervals (→ [93](#)).

### Oil seals

Oil seals are contact seals that are used to seal unit housings at emerging elements, such as shafts, from the environment. Oil seals are wear parts with a service life that is influenced by various factors, such as:

- Shaft speed and circumferential velocity at the sealing lip
- Ambient conditions (temperature, dust, humidity, pressure, chemicals, radiation)
- Lubricant (type, viscosity, additives, pollution)
- Surface quality of the sealing
- Lubricant supply of the sealing
- Oil seal material

**Cam ring/  
Coupling ring**

Due to the various influencing factors it is not possible to predict the service life. Therefore the oil seals must be inspected regularly. Note the respective inspection and maintenance intervals in chapters Inspection/maintenance intervals (→ 92), Lubricant change intervals (→ 93), Maintenance of AL/AM/AQ./EWH adapter (→ 93) and AD input shaft assembly maintenance (→ 94).

The couplings used in the AM, AL, AQ. and EWH adapters are designed to be positive, puncture-proof and low-maintenance claw couplings. They have a an impact and vibration-absorbing cam ring (AM, EWH) or coupling ring (AQ., AL). The service life of cam ring/coupling ring is influenced by various factors, such as:

- Ambient conditions (temperature, chemicals, radiation)
- Operational conditions (starting frequency, impact characteristics)

Note the respective inspection and maintenance intervals in chapters Maintenance of AL/AM/AQ./EWH adapter (→ 93).

### 6.3 Inspection/maintenance intervals

The following gear units are lubricated for life:

- Helical gear units R07, R17, R27
- Parallel-shaft helical gear unit F27
- SPIROPLAN® gear units

If necessary touch up or renew the surface protection/ corrosion protection coating.

The following table lists the obligatory intervals and the corresponding measures:

Time interval	What to do?
<ul style="list-style-type: none"> <li>• Every 3000 hours of operation, at least every 6 months</li> </ul>	<ul style="list-style-type: none"> <li>• Check oil and oil level</li> <li>• Check running noise for possible bearing damage</li> <li>• Visual inspection of the seals for leakage</li> <li>• For gear units with a torque arm: Check and replace the rubber buffers, if necessary</li> </ul>
<ul style="list-style-type: none"> <li>• Depending on the operating conditions (see illustration below), every 3 years at the latest</li> <li>• according to oil temperature</li> </ul>	<ul style="list-style-type: none"> <li>• Change mineral oil</li> <li>• Replace rolling bearing grease (recommendation)</li> <li>• Replace oil seal (do not install it in the same track)</li> </ul>
<ul style="list-style-type: none"> <li>• Depending on the operating conditions (see illustration below), every 5 years at the latest</li> <li>• according to oil temperature</li> </ul>	<ul style="list-style-type: none"> <li>• Change synthetic oil</li> <li>• Replace rolling bearing grease (recommendation)</li> <li>• Replace oil seal (do not install it in the same track)</li> </ul>
<ul style="list-style-type: none"> <li>• Varying (depending on external factors)</li> </ul>	<ul style="list-style-type: none"> <li>• Touch up or renew the surfaces/anti-corrosion coating</li> </ul>

### 6.4 Lubricant change intervals

The following image depicts the change intervals for standard gear units under normal ambient conditions. In case of special designs under severe/aggressive ambient conditions change the lubricant more frequently.

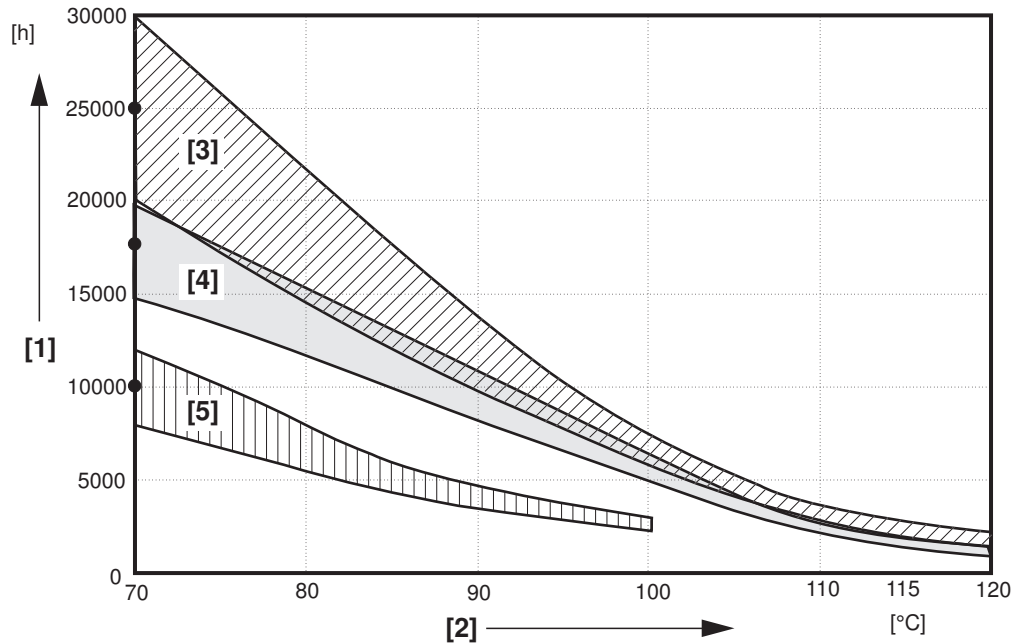

9007199273470603

- [1] Operating hours
  - [2] Sustained oil bath temperature
  - [3] CLP PG
  - [4] CLP HC / HCE (food grade lubricants for the food industry)
  - [5] CLP / HLP / E (lubricants made of biodegradable oils for agriculture, forestry, and water management)
- Average value per oil type at 70 °C

### 6.5 Maintenance of AL/AM/AQ./EWH adapter

The following table lists the obligatory intervals and the corresponding measures:

Time interval	What to do?
<ul style="list-style-type: none"> <li>• Every 3000 hours of operation, at least every 6 months</li> </ul>	<ul style="list-style-type: none"> <li>• Check the running noises to detect possible bearing damage.</li> <li>• Visually check the adapter for leakage.</li> </ul>
<ul style="list-style-type: none"> <li>• After 10000 operating hours</li> </ul>	<ul style="list-style-type: none"> <li>• Check the rotational clearance.</li> <li>• Visual check the cam ring (AM, EWH) or coupling ring (AQ., AL).</li> <li>• Change the bearing grease.</li> <li>• Change the oil seal. Do not mount it in the same track.</li> </ul>

21932786/EN – 05/2015

## 6.6 AD input shaft assembly maintenance

The following table lists the obligatory intervals and the corresponding measures:

Time interval	What to do?
<ul style="list-style-type: none"> <li>• Every 3000 hours of operation, at least every 6 months</li> </ul>	<ul style="list-style-type: none"> <li>• Check the running noises to detect possible bearing damage.</li> <li>• Visually check the adapter for leakage.</li> </ul>
<ul style="list-style-type: none"> <li>• After 10000 operating hours</li> </ul>	<ul style="list-style-type: none"> <li>• Change the bearing grease.</li> <li>• Change the oil seal. Do not mount it in the same track.</li> </ul>

## 6.7 Inspection/maintenance for the gear unit

### 6.7.1 Checking the oil level and changing the oil

The procedure when checking the oil level and changing the oil depends on gear unit type, size and mounting position. Determine the key letter (A, B, C, D or E) in the following table in regard of gear unit type and size. The key letter indicates the procedure for the respective gear unit, that can be found in the second table.

Gear unit type	Size	Code letter for chapter "Checking the oil level and changing the oil"					
		M1	M2	M3	M4	M5	M6
R	R..07 – 27	B					
	R..37 / R..67	A					
	R..47 / R..57	A			B		A
	R..77 – 167	A					
	RX..57– 107	A					
F	F..27	B					
	F..37 – 157	A					
K	K..19 / K..29	C					
	K..39 / K49	A					
	K..37 – 187	A					
S	S..37	C					
	S..47 – 97	A					
W	W..10 – 30	B					
	W..37 – 47	D			E	D	

Code letter	Chapter "Checking the oil level and changing the oil"	Reference
<b>A:</b>	<ul style="list-style-type: none"> <li>• Helical gear units...</li> <li>• Parallel-shaft helical gear units...</li> <li>• Helical-bevel gear unit ...K..39 / K..49, K..37 – 187</li> <li>• Helical-worm gear units... S..47 – 97</li> </ul> <p><b>With oil level plug</b></p>	(→ 96)
<b>B:</b>	<ul style="list-style-type: none"> <li>• Helical gear units...</li> <li>• Parallel-shaft helical gear units...</li> <li>• SPIROPLAN® gear units...</li> </ul> <p><b>Without oil level plug, with cover plate</b></p>	(→ 98)
<b>C:</b>	<ul style="list-style-type: none"> <li>• Helical-worm gear units S..37</li> <li>• Helical-bevel gear units K..19 / K..29</li> </ul> <p><b>Without oil level plug, without cover plate</b></p>	(→ 102)
<b>D:</b>	<ul style="list-style-type: none"> <li>• SPIROPLAN® W..37 / W..47</li> </ul> <p><b>In mounting positions M1, M2, M3, M5, M6 with oil level plug</b></p>	(→ 105)

21932786/EN – 05/2015

Code letter	Chapter "Checking the oil level and changing the oil"	Reference
E:	<ul style="list-style-type: none"> <li>SPIROPLAN® W..37 / W..47...</li> </ul> <b>In mounting position M4 without oil level plug and cover plate</b>	(→ 107)

For notes on the mounting positions, refer to chapter "Mounting Positions (→ 110)".

You cannot check the oil level of gear units in pivoted mounting position. The gear units are delivered with the correct oil level. Observe the designations and fill quantities on the nameplate if you have to change the oil.

### 6.7.2 A: Helical, parallel-shaft helical, helical-bevel and helical-worm gear units with oil level plug

#### Checking the oil level at the oil level plug

Proceed as follows to check the oil level of the gear unit:

1. Observe the notes in chapter "Information on gear unit inspection/maintenance" (→ 88).
2. Determine the position of the oil level plug and the breather valve using the mounting position sheets. See chapter "Mounting positions" (→ 110).
3. Place a container underneath the oil level plug.
4. Slowly remove the oil level plug. Small amounts of oil may leak out as the permitted maximum oil level is higher than the lower edge of the oil level bore.
5. Check the oil level according to the following figure and the corresponding table.

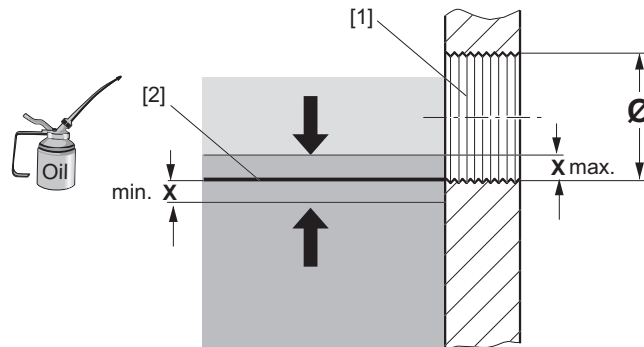

634361867

- [1] Oil level bore  
 [2] Ideal oil level
- X min/max oil level

Ø oil level bore	Approved oil level fluctuation x mm
M10 x 1	1.5
M12 x 1.5	2
M22 x 1.5	3
M33 x 2	4
M42 x 2	5

6. Proceed as follows if the oil level is too low:

- Fill in fresh oil of the same type (contact SEW-EURODRIVE if necessary) via the breather bore, up to the lower edge of the oil level bore.
- Re-insert the breather valve.

21932786/EN – 05/2015



7. Screw in the oil level plug again.

### Checking the oil via the oil drain plug

Proceed as follows to check the gear unit oil:

1. Observe the notes in section "Information on gear unit inspection/maintenance" (→ 88).
2. Determine the position of the oil drain plug using the mounting position sheets. See chapter "Mounting positions" (→ 110).
3. Remove a little oil from the oil drain plug.
4. Check the oil consistency:
  - Viscosity
  - If you can see that the oil is heavily contaminated, SEW-EURODRIVE recommends to change the oil even if this is outside the service intervals specified in "Inspection and maintenance intervals" (→ 92).
5. Check the oil level. See section "Checking the oil level via the oil level plug" (→ 96).

### Changing the oil via the oil drain plug and the breather valve



#### ▲ WARNING

Risk of burns due to hot gear unit and hot gear unit oil.

Severe injuries.

- Let the gear unit cool down before you start working on it. Due to the better flowability, the gear unit oil should still be warm so that the gear unit can be drained best.
1. Observe the notes in chapter "Information on gear unit inspection/maintenance" (→ 88).
  2. Determine the position of the oil drain plug, the oil level plug and the breather valve using the mounting position sheets. See chapter "Mounting positions" (→ 110).
  3. Place a container underneath the oil drain plug.
  4. Remove the oil level plug, the breather valve and the oil drain plug.
  5. Drain the oil completely.
  6. Re-insert the oil drain plug.
  7. Fill in fresh oil of the same type (contact SEW-EURODRIVE if necessary) via the breather bore. Do not mix different synthetic lubricant.
    - Observe the oil quantity according to the specifications on the nameplate or according to the mounting position. See chapter "Lubricant fill quantities".
    - Check the oil level at the oil level plug.
  8. Re-insert the oil level plug and the breather valve.

### 6.7.3 B: Helical, parallel shaft helical, SPIROPLAN® gear units without oil level plug with cover plate

#### Checking the oil level via the cover plate

For gear units without oil level bore, the oil level is checked via the cover plate opening. Proceed as follows:

1. Observe the notes in section "Information on gear unit inspection/maintenance" (→ 88).
2. To position the cover plate on the top, place the gear unit in the following mounting position:
  - R07 - R57 in M1 mounting position
  - F27 in M3 mounting position
  - W10 - W30 in M1 mounting position
3. Loosen the screws [1] of the cover plate [2] and remove the cover plate [2] and the corresponding gasket [3] (see following figure).

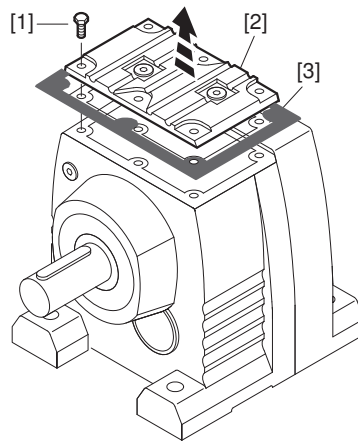

9007199273384203

4. Determine the vertical distance "x" between oil level and sealing surface of the gear unit housing (see following figure).

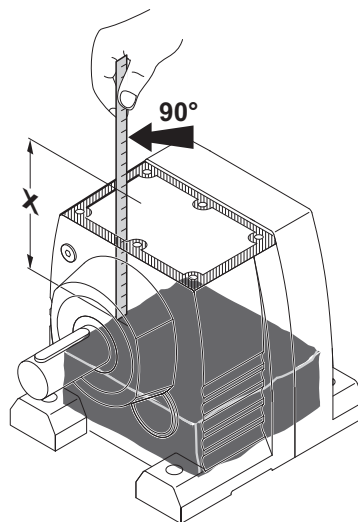

9007199273387275

21932786/EN – 05/2015

5. Compare the determined value "x" to the max. distance between oil level and sealing surface of the gear unit housing specified in the following table. Adjust the fill level if required.

Gear unit type		Max. distance x in mm between oil level and sealing surface of the gear unit housing for mounting position					
		M1	M2	M3	M4	M5	M6
R07	2-stage	52 ± 1	27 ± 1	27 ± 1	27 ± 1	27 ± 1	27 ± 1
	3-stage	49 ± 1	21 ± 1	21 ± 1	21 ± 1	21 ± 1	21 ± 1
R17	2-stage	63 ± 1	18 ± 1	46 ± 1	18 ± 1	46 ± 1	46 ± 1
	3-stage	58 ± 1	11 ± 2	40 ± 2	11 ± 2	40 ± 2	40 ± 2
R27	2-stage	74 ± 1	22 ± 1	45 ± 1	22 ± 1	45 ± 1	45 ± 1
	3-stage	76 ± 1	19 ± 1	42 ± 1	19 ± 1	42 ± 1	42 ± 1
R47	2-stage	–	–	–	–	39 ± 1	–
	3-stage	–	–	–	–	32 ± 1	–
R57	2-stage	–	–	–	–	32 ± 1	–
	3-stage	–	–	–	–	28 ± 1	–
F27	2-stage	78 ± 1	31 ± 1	72 ± 1	56 ± 1	78 ± 1	78 ± 1
	3-stage	71 ± 1	24 ± 1	70 ± 1	45 ± 1	71 ± 1	71 ± 1
		Irrespective of mounting position					
W10		12 ± 1					
W20		19 ± 1					
W30		31 ± 1					

6. Close the gear unit after the oil level check:
- Re-attach the gasket of the cover plate. Make sure that the sealing surfaces are clean and dry.

- Screw on the cover plate. Tighten the cover plate screw connections working from the inside to the outside. Tighten the cover plate screw connections in the sequence depicted in the following figure. Tighten the cover plate screw connections with the specified tightening torque according to the following table. Repeat the tightening procedure until the screws are properly tightened. To avoid damaging the cover plate, use only impulse wrenches or torque wrenches. Do not use impact screwdrivers.

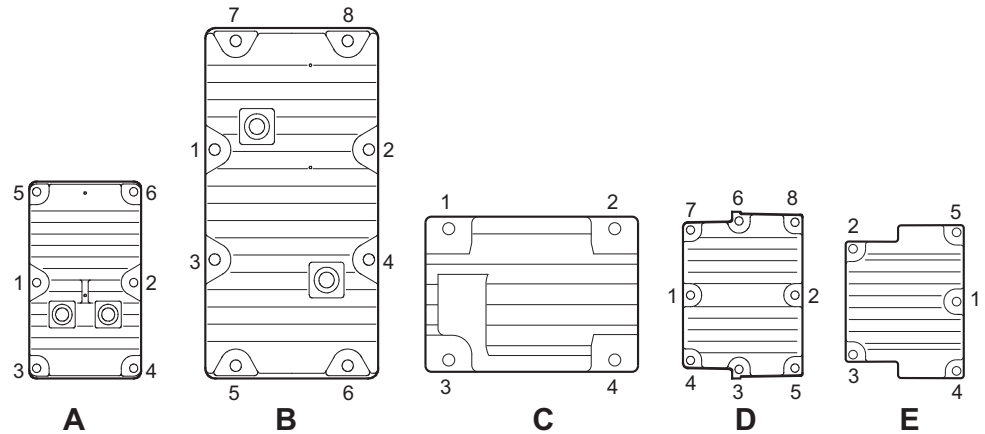

9007199273390731

Gear unit type	Figure	Retaining thread	Tightening torque $T_N$ Nm	Minimum tightening torque $T_{min}$ Nm
R/RF07	E	M5	6	4
R/RF17/27	D	M6	11	7
R/RF47/57	A			
F27	B	M5	6	4
W10	C			
W20	C			
W30	A	M6	11	7

### Checking the oil via cover plate

Proceed as follows to check the gear unit oil:

1. Observe the notes in chapter "Information on gear unit inspection/maintenance" (→ 88).
2. Open the cover plate of the gear unit according to section "Checking the oil level via the cover plate" (→ 98).
3. Take an oil sample via the cover plate opening.
4. Check the oil consistency.
  - Viscosity
  - If you can see that the oil is heavily contaminated, SEW-EURODRIVE recommends to change the oil even if this is outside the service intervals specified in "Inspection and maintenance intervals" (→ 95).
5. Check the oil level. See section "Checking the oil level via the cover plate" (→ 98).

6. Screw on the cover plate. Observe the order and the tightening torques according to section "Checking the oil level via the cover plate".

### Changing the oil via the cover plate



#### ▲ WARNING

Risk of burns due to hot gear unit and hot gear unit oil.

Severe injuries.

- Let the gear unit cool down before you start working on it. Due to the better flowability, the gear unit oil should still be warm so that the gear unit can be drained best.
1. Observe the notes in chapter "Information on gear unit inspection/maintenance" (→ 88).
  2. Open the cover plate of the gear unit according to chapter "Checking the oil level via the cover plate".
  3. Completely drain the oil into a container via the cover plate opening.
  4. Fill in fresh oil of the same type (contact SEW-EURODRIVE if necessary) via the cover plate. Do not mix different synthetic lubricants.
    - Pour in the oil as specified on the nameplate or in accordance with the mounting position. See chapter "Lubricant fill quantities".
  5. Check the oil level.
  6. Screw on the cover plate. Observe the order and the tightening torques according to chapter "Checking the oil level via the cover plate" (→ 98).

### 6.7.4 C: Helical-worm gear units S..37 and helical-bevel gear units K..19/K..29 without oil level plug and cover plate

#### Checking the oil level via screw plug

The gear units S..37, K..19, and K..29 are not equipped with an oil level plug or a cover plate. This is why the oil level is checked via the control bore.

1. Observe the notes in chapter "Information on gear unit inspection/maintenance" (→ 88).
2. Place the gear unit in the mounting position stated in the following table. Thus the control bore always points upwards.

Gear unit	Mounting position
S..37	M5/M6
K19/29	M6

3. Remove the screw plug [1] as shown in the following figure.

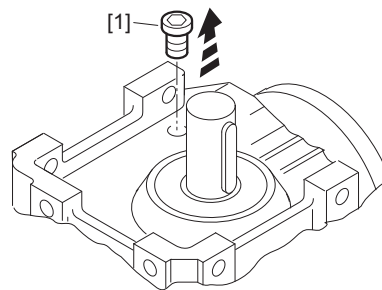

18655371

4. Insert the dipstick vertically via the control bore all the way to the bottom of the gear unit housing. Vertically pull the dipstick out of the control bore, as shown in the following figure.

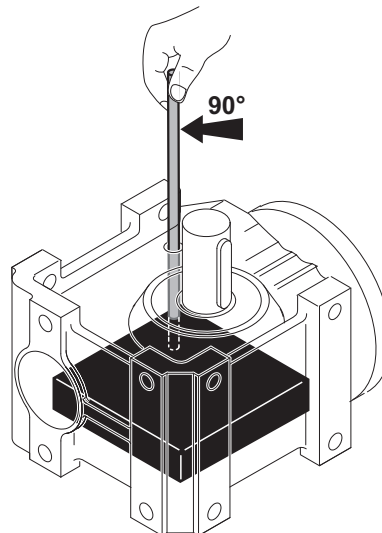

18658699

21932786/EN – 05/2015

- Determine the size of the section "x" of the dipstick covered with lubricant using a slide-gauge as depicted in the following figure.

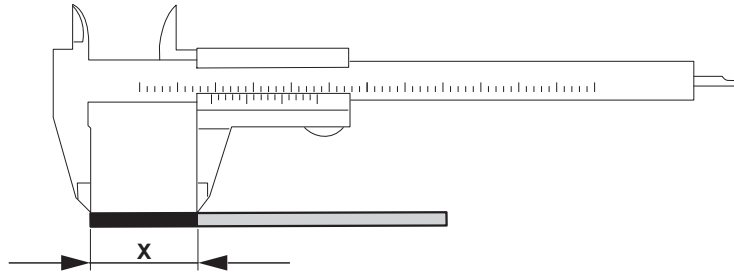

18661771

- Compare the determined value "x" to the min. value depending on the mounting position specified in the following table. Correct the fill level if required.

Gear unit type	Oil level = wetted section x [mm] of the dipstick					
	Mounting position					
	M1	M2	M3	M4	M5	M6
K..19	33 ± 1	33 ± 1	33 ± 1	35 ± 1	33 ± 1	33 ± 1
K..29	50 ± 1	50 ± 1	50 ± 1	63 ± 1	50 ± 1	50 ± 1
S..37	10 ± 1	24 ± 1	34 ± 1	37 ± 1	24 ± 1	24 ± 1

- Re-insert and tighten the screw plug.

### Checking the oil via the screw plug

- Observe the notes in chapter "Information on gear unit inspection/maintenance" (→ 88).
- Open the screw plug of the gear unit according to section "Checking the oil level via screw plug".
- Take an oil sample via the screw plug bore.
- Check the oil consistency.
  - Viscosity
  - If you can see that the oil is heavily contaminated, SEW-EURODRIVE recommends to change the oil even if this is outside the service intervals specified in "Inspection and maintenance intervals" (→ 92).
- Check the oil level. See previous section.
- Re-insert and tighten the screw plug.

### Changing the oil via the screw plug

#### ▲ WARNING

Risk of burns due to hot gear unit and hot gear unit oil.

Severe injuries.

- Let the gear unit cool down before you start working on it. Due to the better flowability, the gear unit oil should still be warm so that the gear unit can be drained best.



1. Observe the notes in chapter "Information on gear unit inspection/maintenance" (→  88).
2. Open the screw plug of the gear unit according to section "Checking the oil level via screw plug".
3. Completely drain the oil via the screw plug bore.
4. Fill in fresh oil of the same type (contact SEW-EURODRIVE if necessary) via the control bore. Do not mix different synthetic lubricants.
  - Observe the oil quantity specified on the nameplate or according to the mounting position. Observe section "Lubricant fill quantities".
5. Check the oil level.
6. Re-insert and tighten the screw plug.



6.7.5 D: SPIROPLAN® W..37/W..47 in mounting position M1, M2, M3, M5, M6 with oil level plug

Checking the oil level at the oil level plug

Proceed as follows to check the oil level of the gear unit:

1. Observe the notes in chapter "Information on gear unit inspection/maintenance" (→ 88).
2. Set up the gear unit in M1 mounting position.
3. Slowly remove the oil level plug (see following figure). Small amounts of oil may leak out.

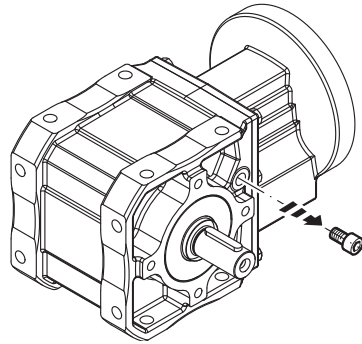

787235211

4. Check the oil level according to the following figure.

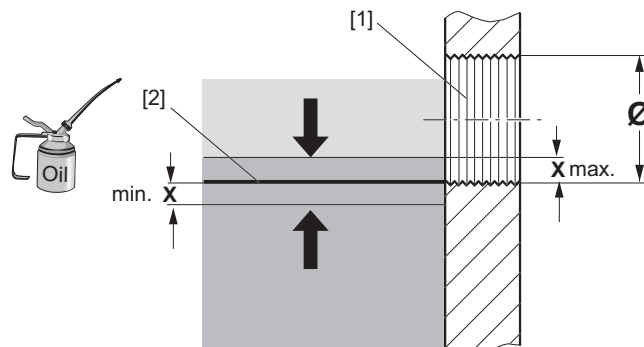

634361867

[1] Oil level bore

[2] Ideal oil level

Ø oil level bore	Fluctuation x for minimum and maximum fill level in mm
M10 x 1	1.5

5. In case the oil level is too low, fill in fresh oil of the same type (contact SEW-EURODRIVE if necessary) via the oil level bore, up to the lower edge of the oil level bore.
6. Screw in the oil level plug again.

Checking the oil level at the oil level plug

Proceed as follows to check the oil of the gear unit:

1. Observe the notes in chapter "Information on gear unit inspection/maintenance" (→ 88).
2. Remove some oil at the oil level plug.

21932786/EN – 05/2015

3. Check the oil consistency.
  - Viscosity
  - If you can see that the oil is heavily contaminated, SEW-EURODRIVE recommends to change the oil even if this is outside the service intervals specified in "Inspection and maintenance intervals" (→ 92).
4. Check the oil level. See previous section.

### Changing the oil at the oil level plug



#### ▲ WARNING

Risk of burns due to hot gear unit and hot gear unit oil.

Severe injuries.

- Let the gear unit cool down before you start working on it. Due to the better flowability, the gear unit oil should still be warm so that the gear unit can be drained best.
- 
1. Observe the notes in chapter "Information on gear unit inspection/maintenance" (→ 88).
  2. Set up the gear unit in M5 or M6 mounting position. See chapter "Mounting positions" (→ 110).
  3. Place a container underneath the oil level plug.
  4. Remove the oil level plugs on the A and B-side of the gear unit.
  5. Drain the oil completely.
  6. Re-insert the lower oil level plug.
  7. Fill in fresh oil of the same type (contact SEW-EURODRIVE if necessary) via the upper oil level plug. Do not mix different synthetic lubricants.
    - Observe the oil quantity according to the specifications on the nameplate or according to the mounting position. See chapter "Lubricant fill quantities".
    - Check the oil level according to chapter "Checking the oil level via oil level plug".
  8. Re-insert the upper oil level plug.

**6.7.6 E: SPIROPLAN® W..37 / W..47 in mounting position M4 without oil level plug and cover plate**  
**Checking the oil level via screw plug**

The W37 / W47 gear units are not equipped with an oil level plug or a cover plate. This is why the oil level is checked via the control bore.

1. Observe the notes in chapter "Information on gear unit inspection/maintenance" (→ 88).
2. Set up the gear unit in M5 or M6 mounting position. See chapter "Mounting positions" (→ 110).
3. Remove the screw plug.
4. Insert the dipstick vertically via the control bore all the way to the bottom of the gear unit housing. Mark the point on the dipstick where it exits the gear unit. Pull out the dipstick vertically (see following figure).

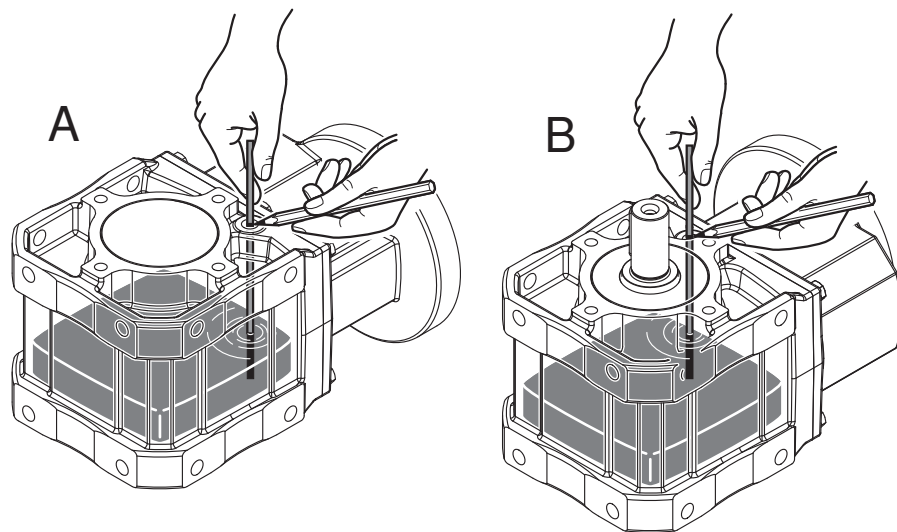

784447371

5. Determine the section "x" between the wetted part and the marking using a caliper (see following figure).

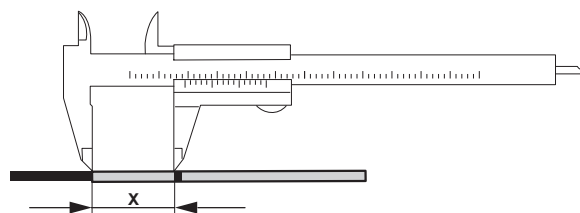

9007200039761803

6. Compare the determined value "x" to the min. value depending on the mounting position specified in the following table. Correct the fill level if required.

Gear unit type	Oil level = wetted section x mm of the dipstick	
	Mounting position during check	
	M5 Lying on the A-side	M6 Lying on the B-side
W37 in M4 mounting position	37 ± 1	29 ± 1

Gear unit type	Oil level = wetted section x mm of the dipstick	
	Mounting position during check	
	M5 Lying on the A-side	M6 Lying on the B-side
W47 in M4 mounting position	41 ± 1	30 ± 1

7. Re-insert and tighten the screw plug.

### Checking the oil via the screw plug

Proceed as follows to check the oil of the gear unit:

1. Observe the notes in chapter "Information on gear unit inspection/maintenance" (→ 88).
2. Remove a little oil at the oil screw plug.
3. Check the oil consistency:
  - Viscosity
  - If you can see that the oil is heavily contaminated, SEW-EURODRIVE recommends to change the oil even if this is outside the service intervals specified in "Inspection and maintenance intervals" (→ 92).
4. Check the oil level. See previous section.

### Changing the oil via the screw plug



#### ▲ WARNING

Risk of burns due to hot gear unit and hot gear unit oil.

Severe injuries.

- Let the gear unit cool down before you start working on it. Due to the better flowability, the gear unit oil should still be warm so that the gear unit can be drained best.
1. Observe the notes in chapter "Information on gear unit inspection/maintenance" (→ 88).
  2. Set up the gear unit in M5 or M6 mounting position. See chapter "Mounting positions" (→ 110).
  3. Place a container underneath the screw plug.
  4. Remove the screw plugs on the A and B-side of the gear unit.
  5. Drain the oil completely.
  6. Re-insert the lower screw plug.
  7. Fill in fresh oil of the same type (contact SEW-EURODRIVE if necessary) via the upper screw plug. Do not mix different synthetic lubricants.
    - For the required oil quantity, refer to the nameplate or chapter "Lubricant fill quantities".
    - Check the oil level according to chapter "Checking the oil level via oil level plug".
  8. Re-insert the upper screw plug.

### 6.7.7 Replacing the oil seal

#### NOTICE

Damage to oil seal when mounted below 0 °C.

Damage to oil seal.

- Store oil seals at ambient temperatures over 0 °C.
- If necessary, heat the oil seal before mounting it.

Proceed as follows:

1. Ensure that there is a sufficient grease reservoir between the dust lip and sealing lip, depending on the gear unit design.
2. If you use double oil seals, the space has to be filled with grease for one third.

### 6.7.8 Painting the gear unit

#### NOTICE

Ingress of paint at breather valve and sealing lips of the oil seal during painting or re-painting of the gear unit.

Damage to oil seal and breather valve.

- Thoroughly cover the breather valve and sealing lip of the oil seals with strips prior to painting.
- Remove the strips after painting.

### 7 Mounting positions

#### 7.1 Designation of the mounting positions

SEW-EURODRIVE distinguishes between the gear unit mounting positions M1 – M6. The following figure shows the gearmotor in the 6 mounting positions:

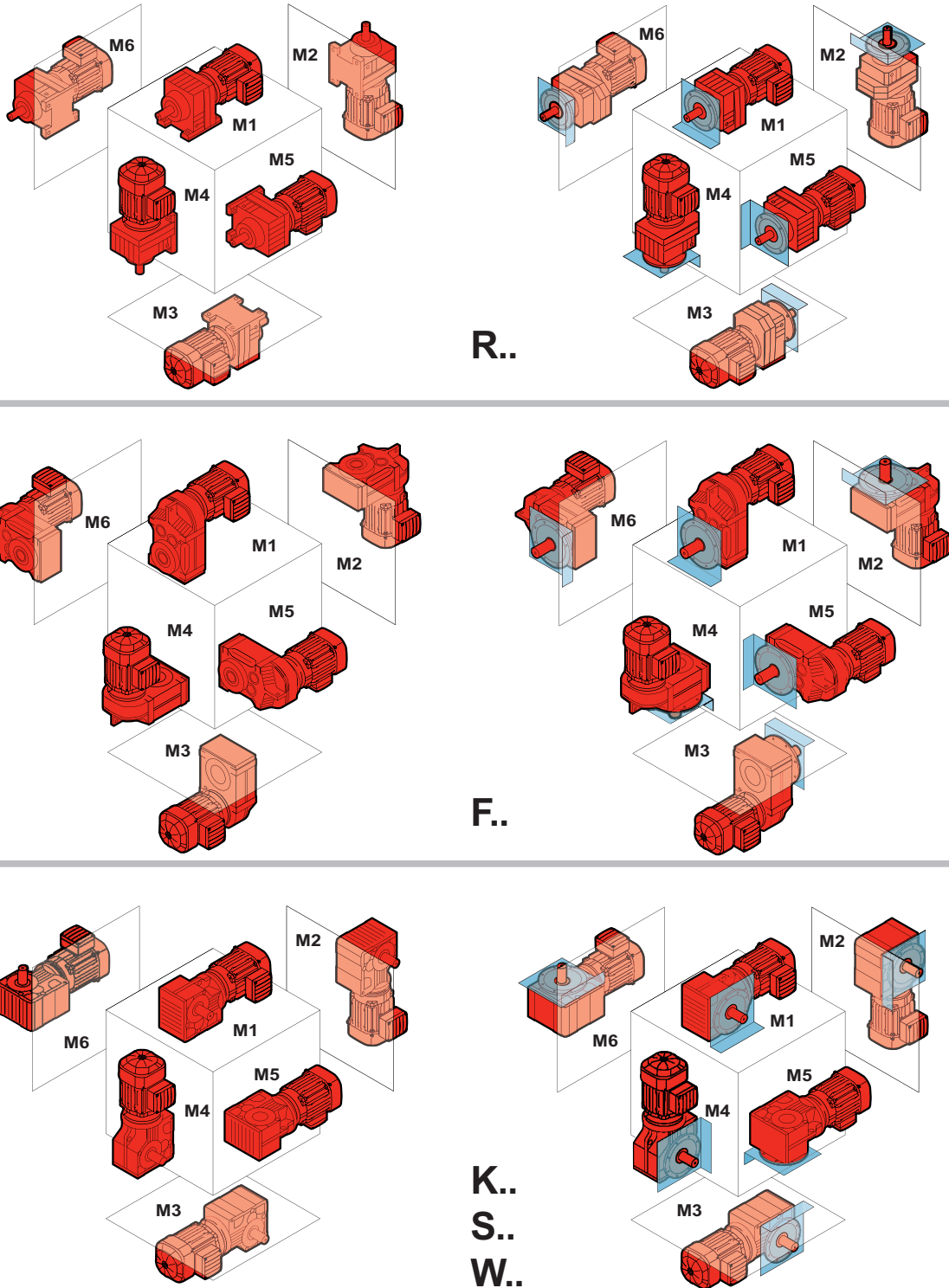

45035996292514699

21932786/EN – 05/2015

## 7.2 Churning losses

\*(→  XY)

Churning losses may occur in some mounting positions. Contact SEW-EURODRIVE in case of the following combinations:

Mounting position	Gear unit type	Gear unit size	Input speed rpm
M2, M4	R	97 ... 107	> 2500
		> 107	>1500
M2, M3, M4, M5, M6	F	97 ... 107	> 2500
		> 107	> 1500
	K	77 ... 107	> 2500
		> 107	> 1500
	S	77 ... 97	> 2500

## 7.3 Mounting position MX

Mounting position MX is available for all gear units of the R..7, F..7, K..7, K..9, S..7 and SPIROPLAN® W series.

For mounting position MX, the gear units are delivered with the maximally possible amount of oil and sealed with oil screw plugs. A breather valve is included with each drive. The oil fill volume must be adapted according to the mounting position of the gear unit. Customers will also have to mount the enclosed breather valve at the proper location depending on the mounting position (see section "Mounting position sheets (→  112)").

Check for the correct oil level, as described in chapter "Oil level check and oil change" (→  95).

## 7.4 Universal mounting position M0

SPIROPLAN® W10 – W30 gearmotors can be ordered with M0 universal mounting position as an option. Gear units with mounting position M0 are filled with the standard oil quantity.

These gear units are entirely enclosed due to their small size and have no breather valve. Customers can use the gear unit universally in every mounting position (M1 – M6) without having to take any measures prior to startup.

## 7.5 Mounting positions of SPIROPLAN® gear units

### NOTICE



SPIROPLAN® gearmotors of sizes W10 – W30 cannot be equipped with breather valves, oil level plugs or oil drain plugs.

### INFORMATION





SPIROPLAN® gearmotors are independent on the mounting position, except for W37 – W47 in M4 mounting position. However, mounting positions M1 to M6 are also shown for SPIROPLAN® gearmotors for a complete overview.

## 7.6 Mounting position sheets

### 7.6.1 Key

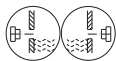
The following table shows the symbols used in the mounting position sheets and what they mean:

Icon	Meaning
	Breather valve
	Oil level plug
	Oil drain plug



7.6.2 Mounting positions of helical gearmotors

RX57-RX107

04 043 03 00

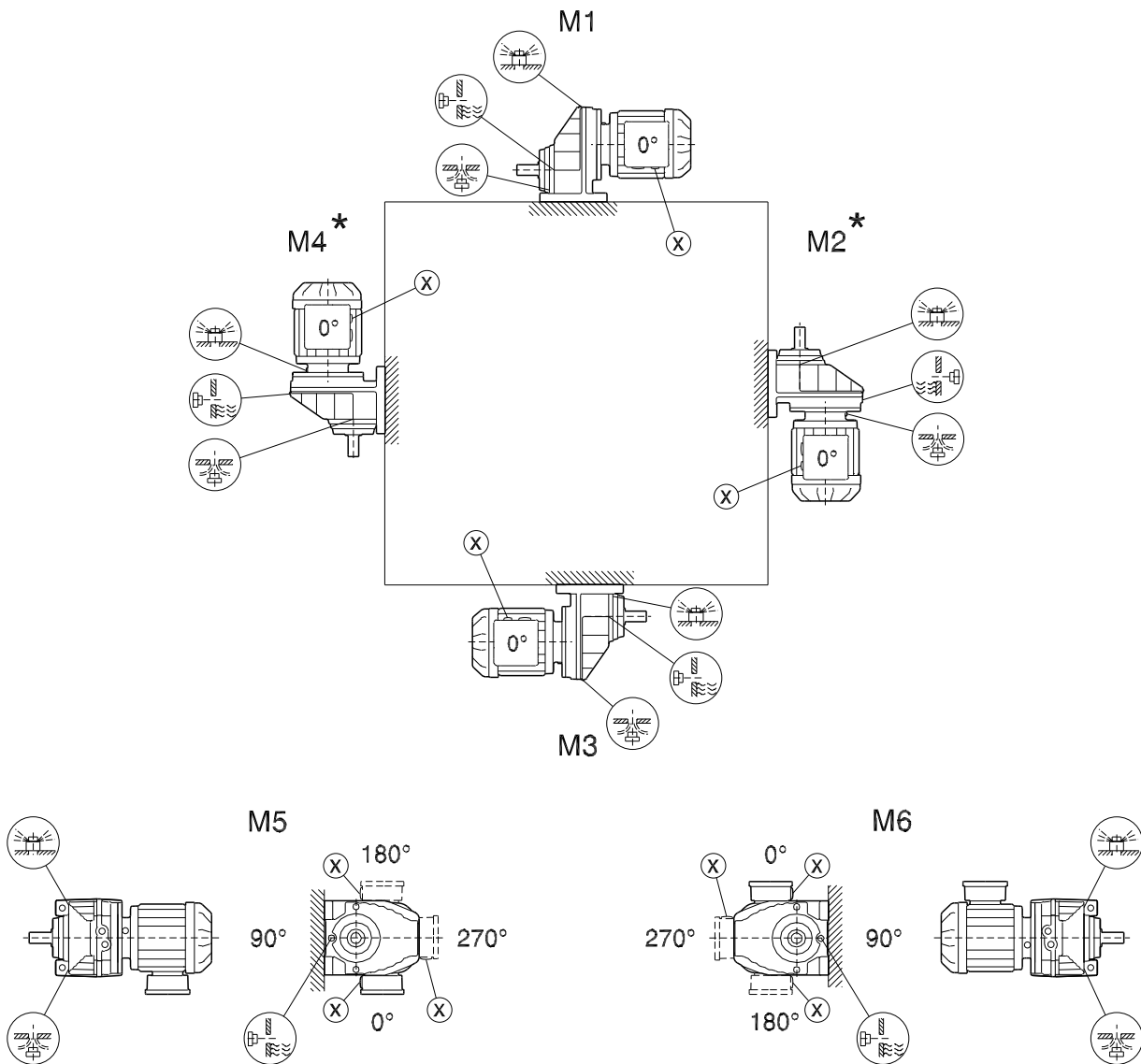
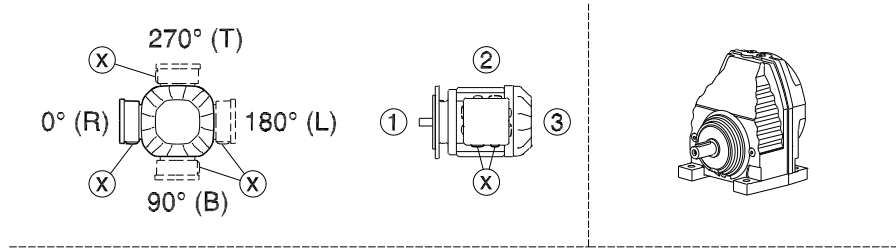

\* (→ 111)

21932786/EN – 05/2015

# 7 Mounting positions

Mounting position sheets

RXF57-RXF107

04 044 03 00

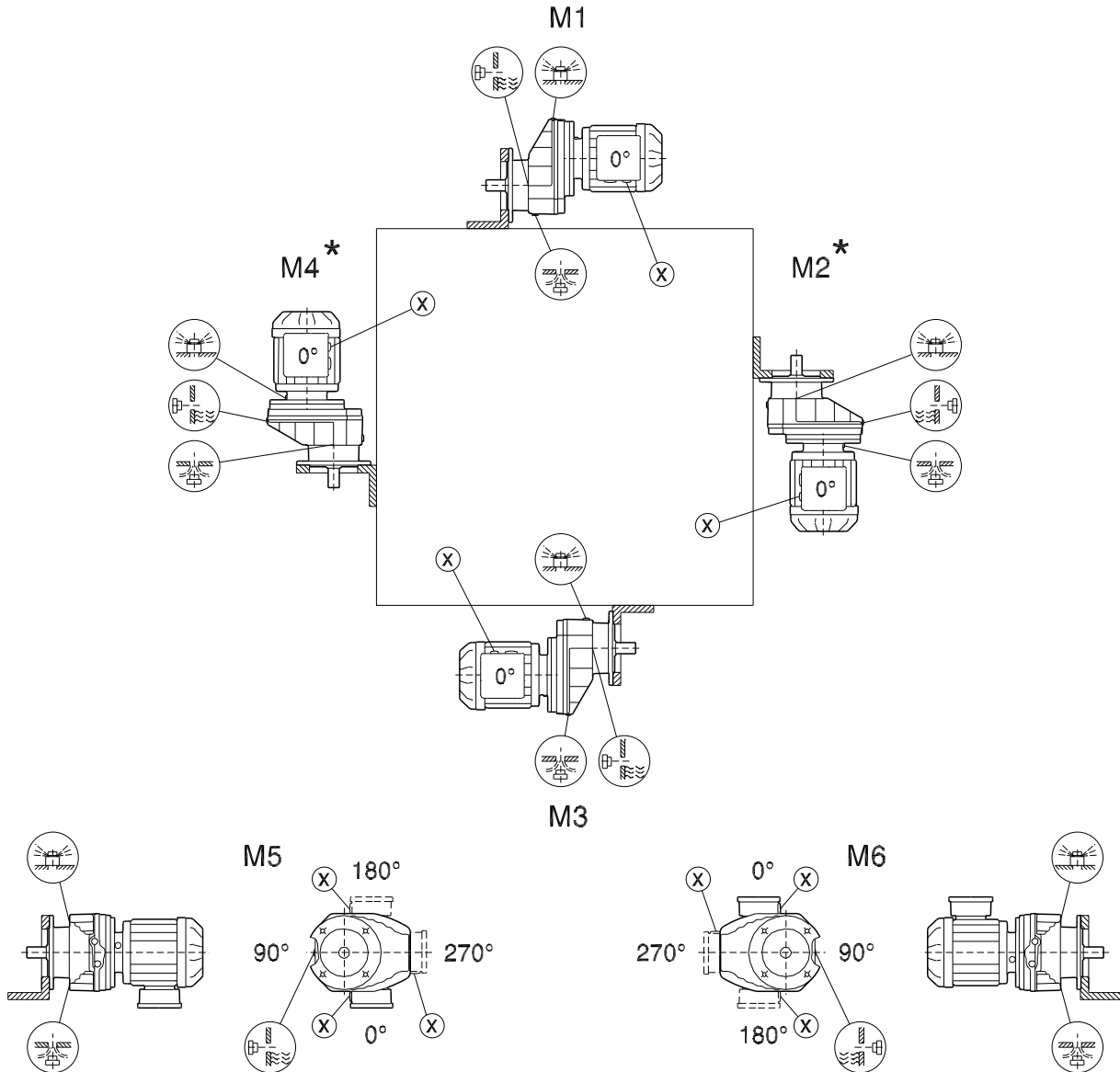
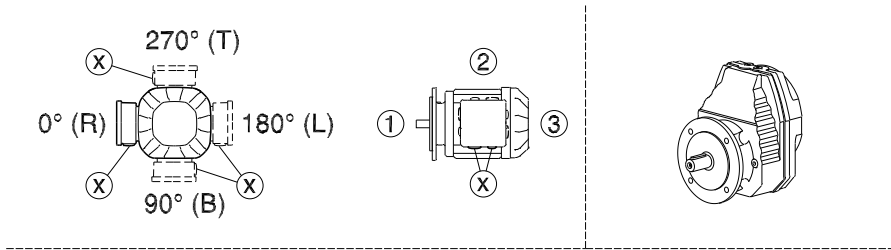

\* (→ 111)

21932786/EN – 05/2015

R07-R167

04 040 04 00

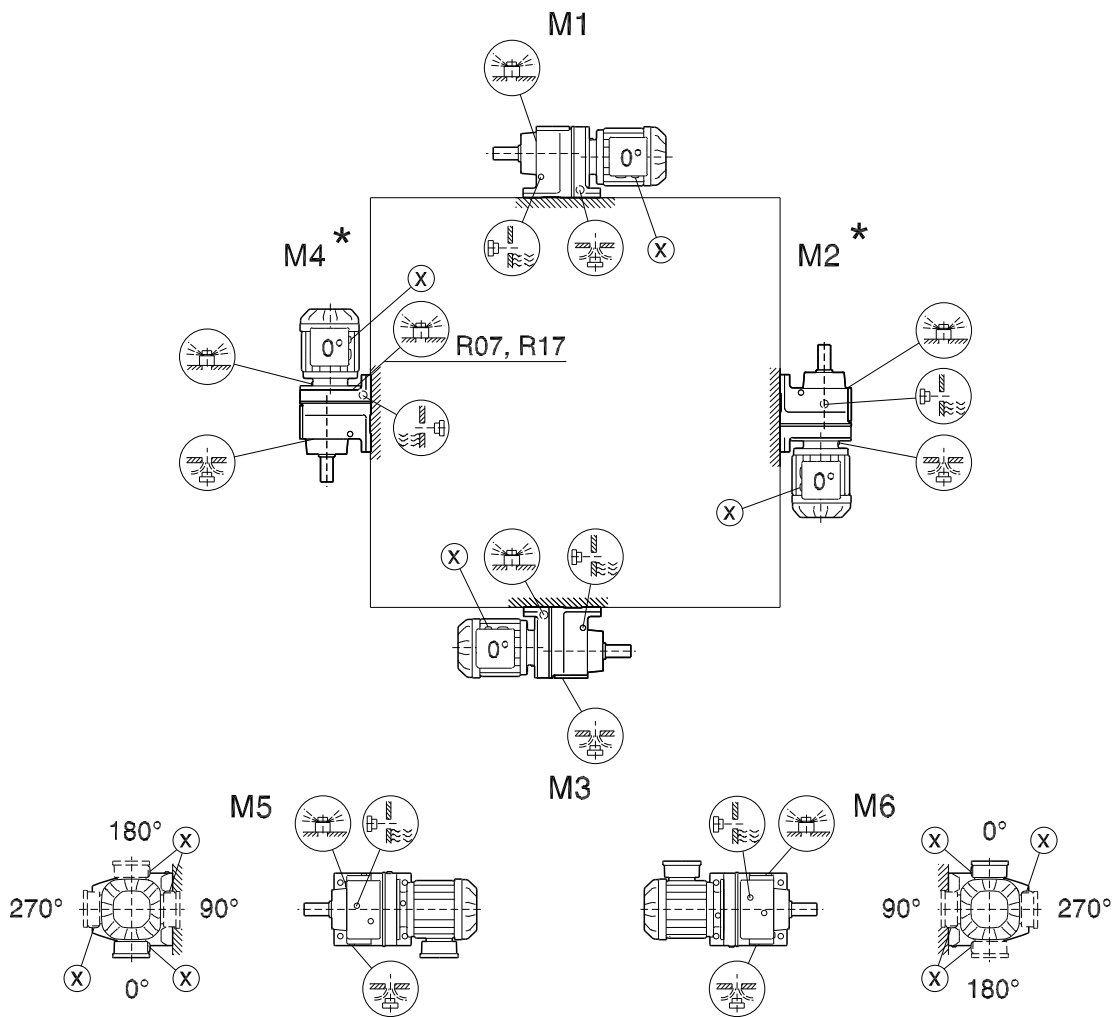
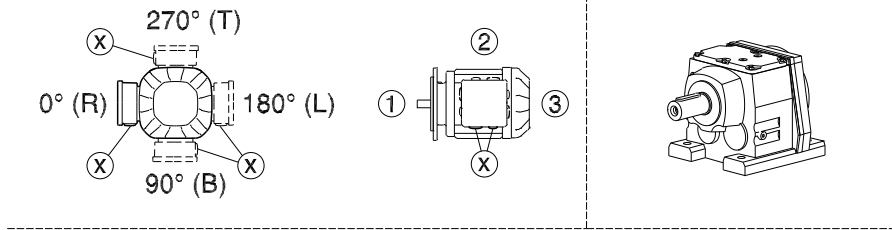

- |               |                    |
|---------------|--------------------|
| R07           | M1, M2, M3, M5, M6 |
| R17, R27      | M1, M3, M5, M6     |
| R07, R17, R27 |                    |
| R47, R57      | M5                 |

\* (→ 111)

# 7 Mounting positions

Mounting position sheets

RF07-RF167, RZ07-RZ87

04 041 04 00

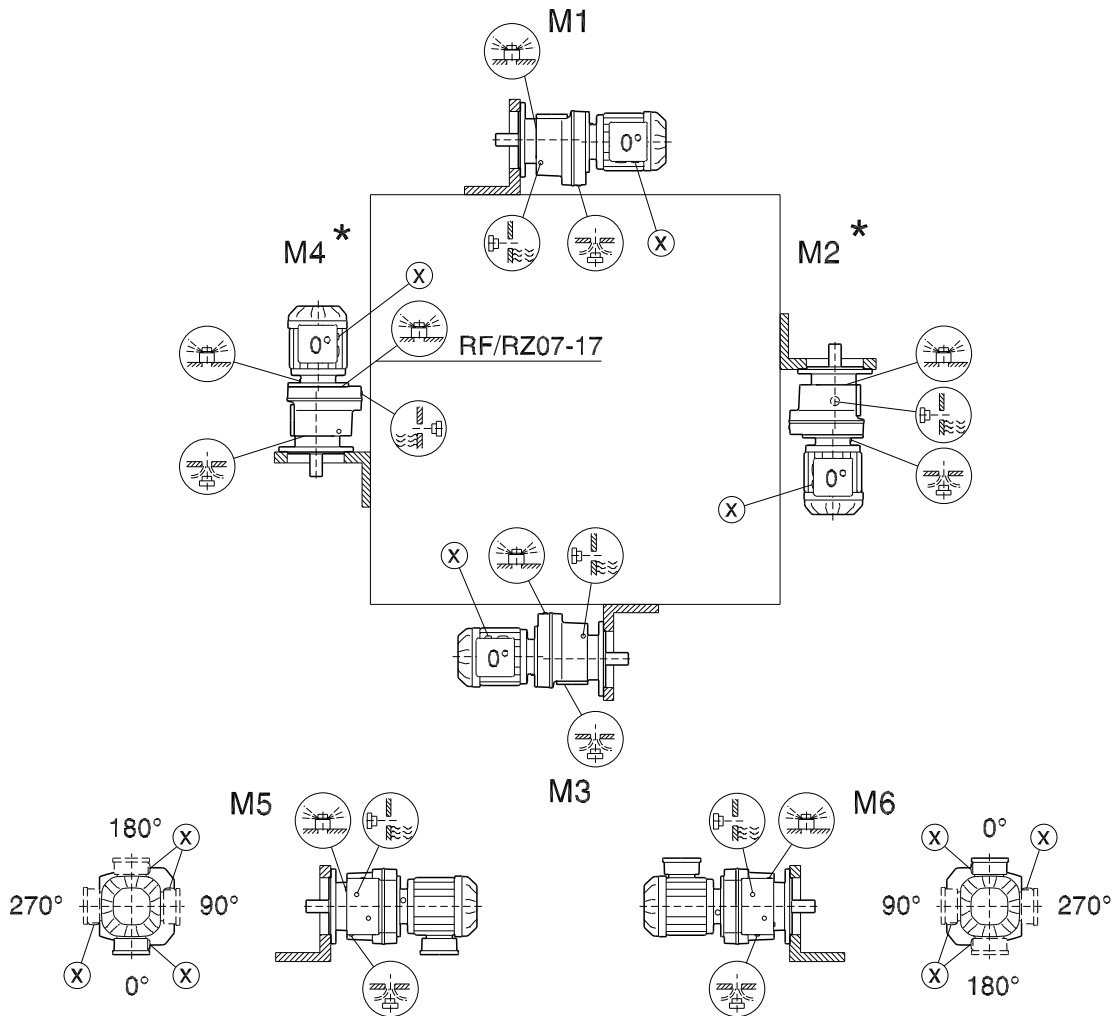
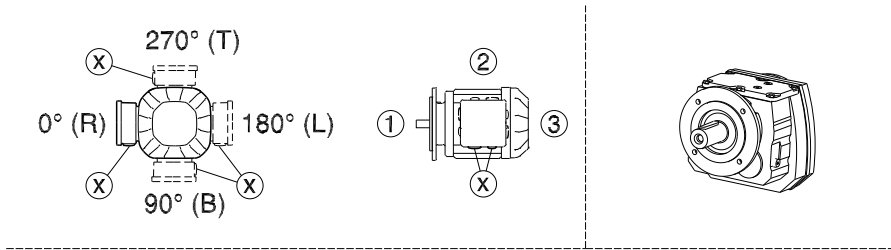

- |                 |  |                    |
|-----------------|--|--------------------|
| RF/RZ07         |  | M1, M2, M3, M5, M6 |
| RF/RZ17, 27     |  | M1, M3, M5, M6     |
| RF/RZ07, 17, 27 |  |                    |
| RF/RZ47, 57     |  | M5                 |

\* (→ 111)

21932786/EN – 05/2015

R07F-R87F

04 042 04 00

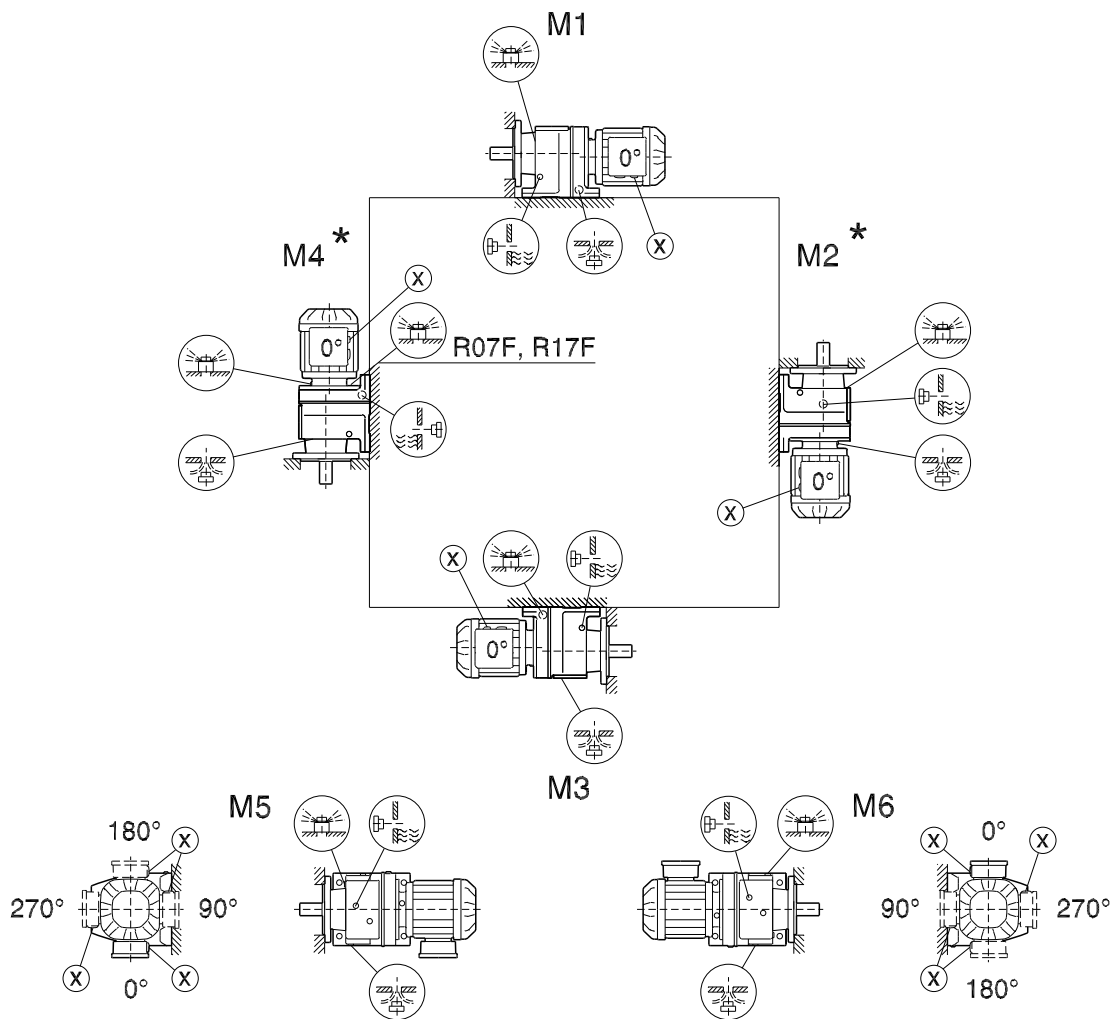
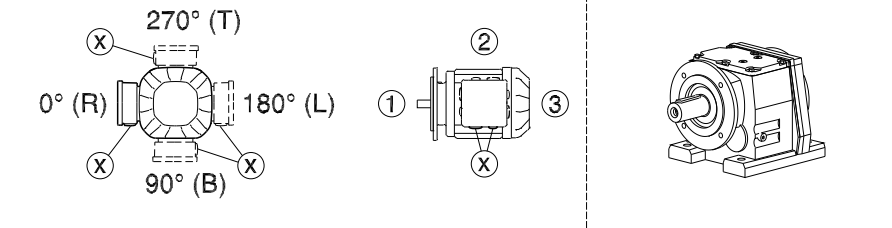

R07F		M1, M2, M3, M5, M6
R17F, R27F		M1, M3, M5, M6
R07F, R17F, R27F		M4, M5
R47F, R57F		M5

\* (→ 111)

# 7 Mounting positions

Mounting position sheets

## 7.6.3 Mounting positions of parallel-shaft helical gearmotors

F/FA..B/FH27B-157B, FV27B-107B

42 042 04 00

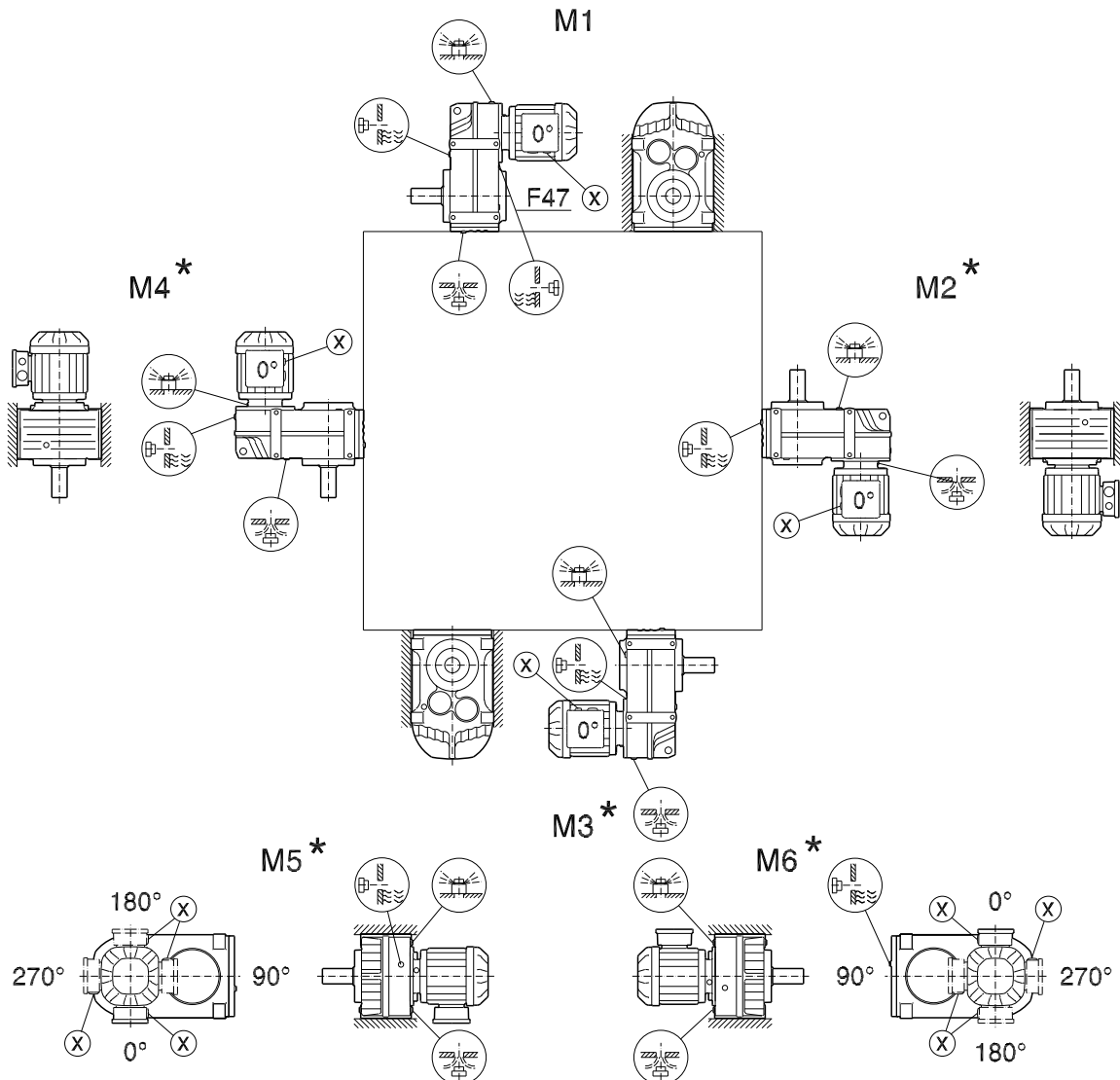
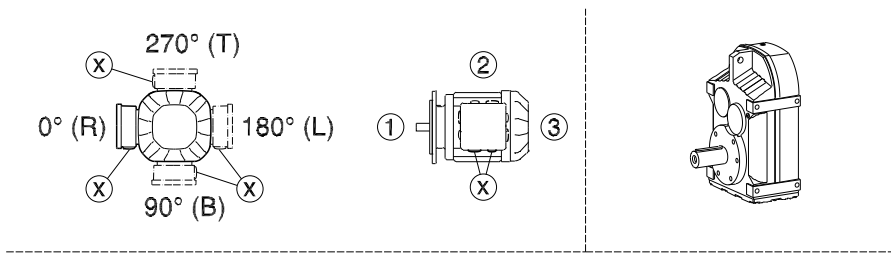

- F..27 M1, M3, M5, M6
- F..27 M1 - M6
- F..27 M1, M3, M5, M6

\* (→ 111)

21932786/EN – 05/2015

FF/FAF/FHF/FZ/FAZ/FHZ27-157, FVF/FVZ27-107

42 043 04 00

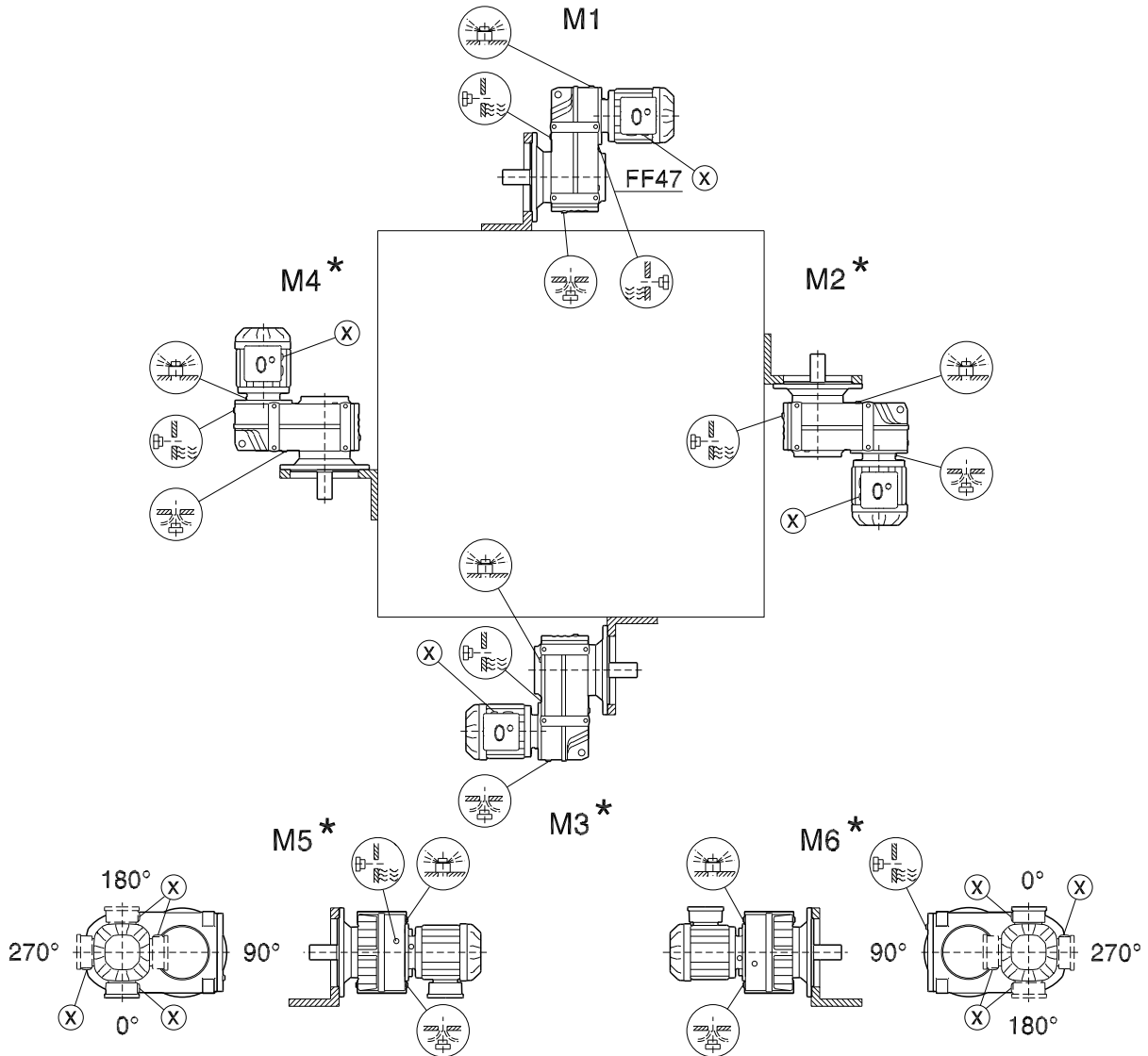
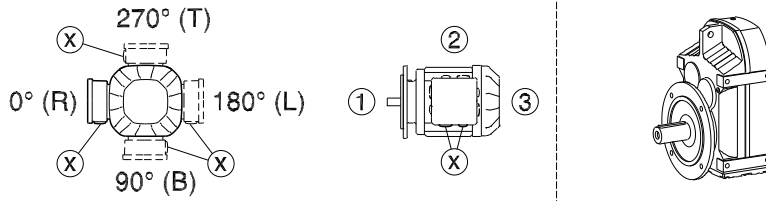

- F..27 M1, M3, M5, M6
- F..27 M1 - M6
- F..27 M1, M3, M5, M6

\* (→ 111)

# 7 Mounting positions

Mounting position sheets

FA/FH27-157, FV27-107, FT37-97

42 044 04 00

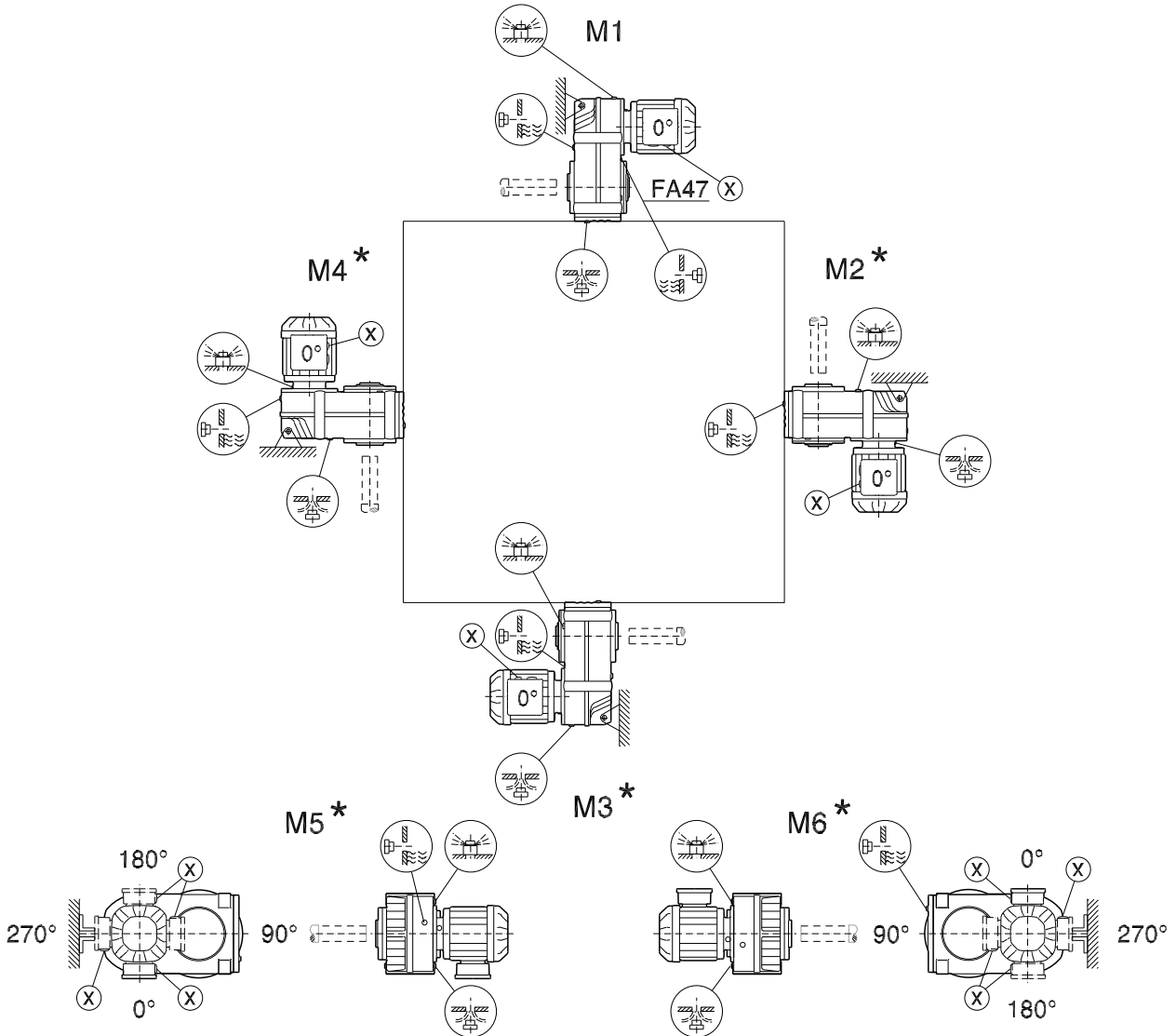
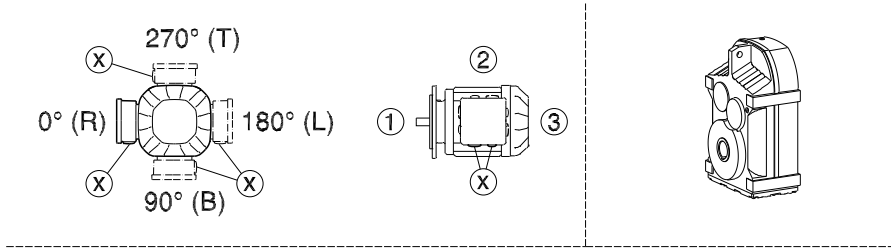

- F..27 M1, M3, M5, M6
- F..27 M1 - M6
- F..27 M1, M3, M5, M6

\* (→ 111)

21932786/EN – 05/2015



7.6.4 Mounting positions of helical-bevel gearmotors

K/KA..B/KH19B-29B

33 023 00 15

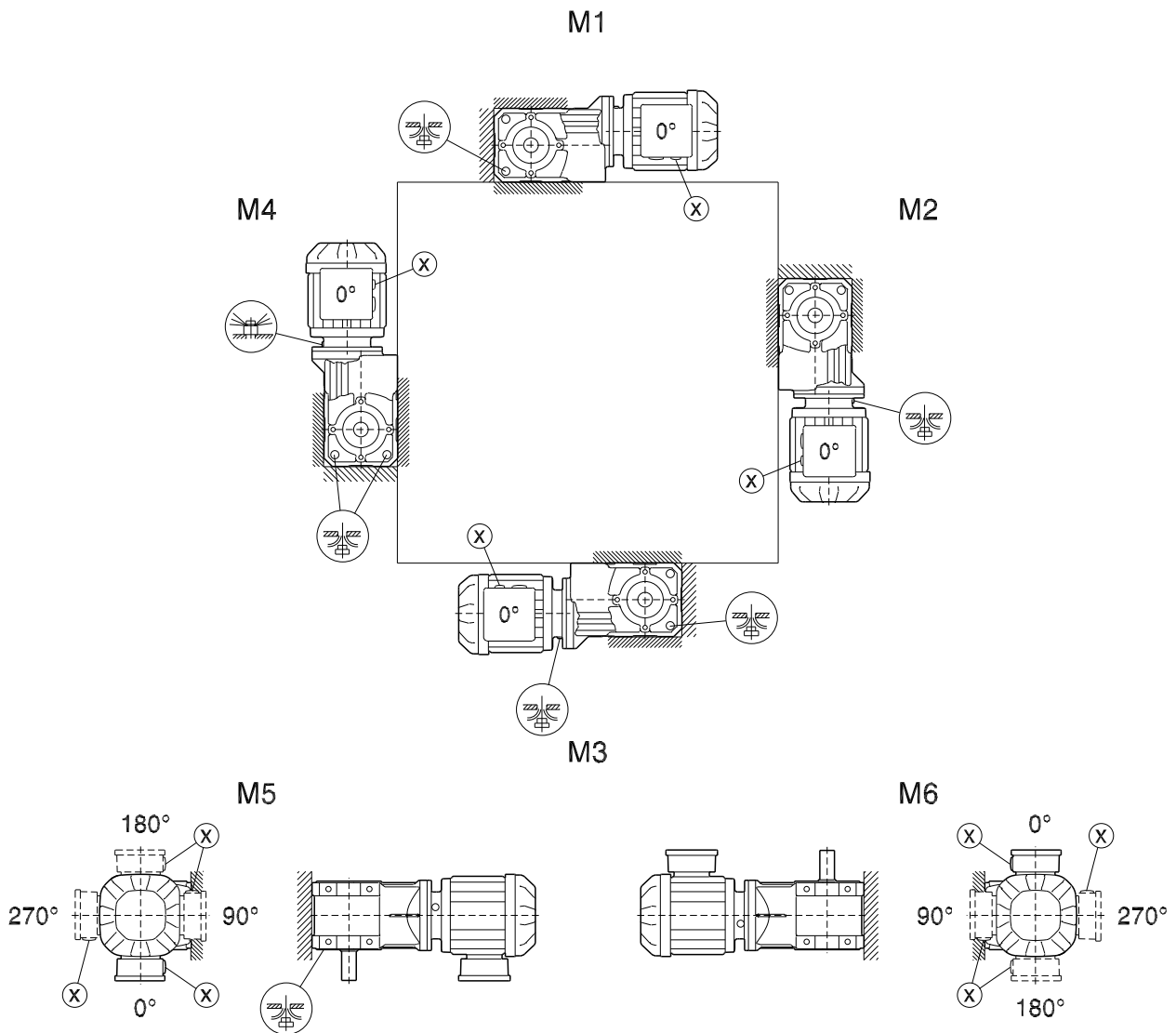
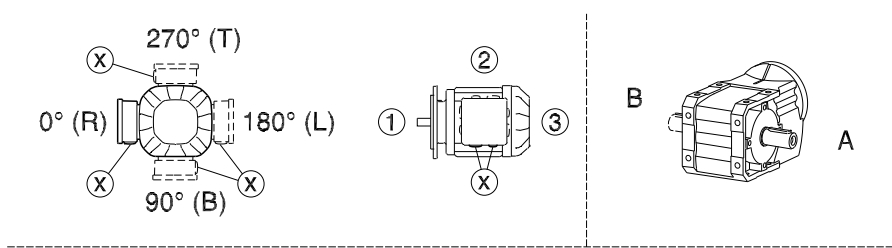

21932786/EN – 05/2015

# 7 Mounting positions

Mounting position sheets

KF..B/KAF..B/KHF19B-29B

33 024 00 15

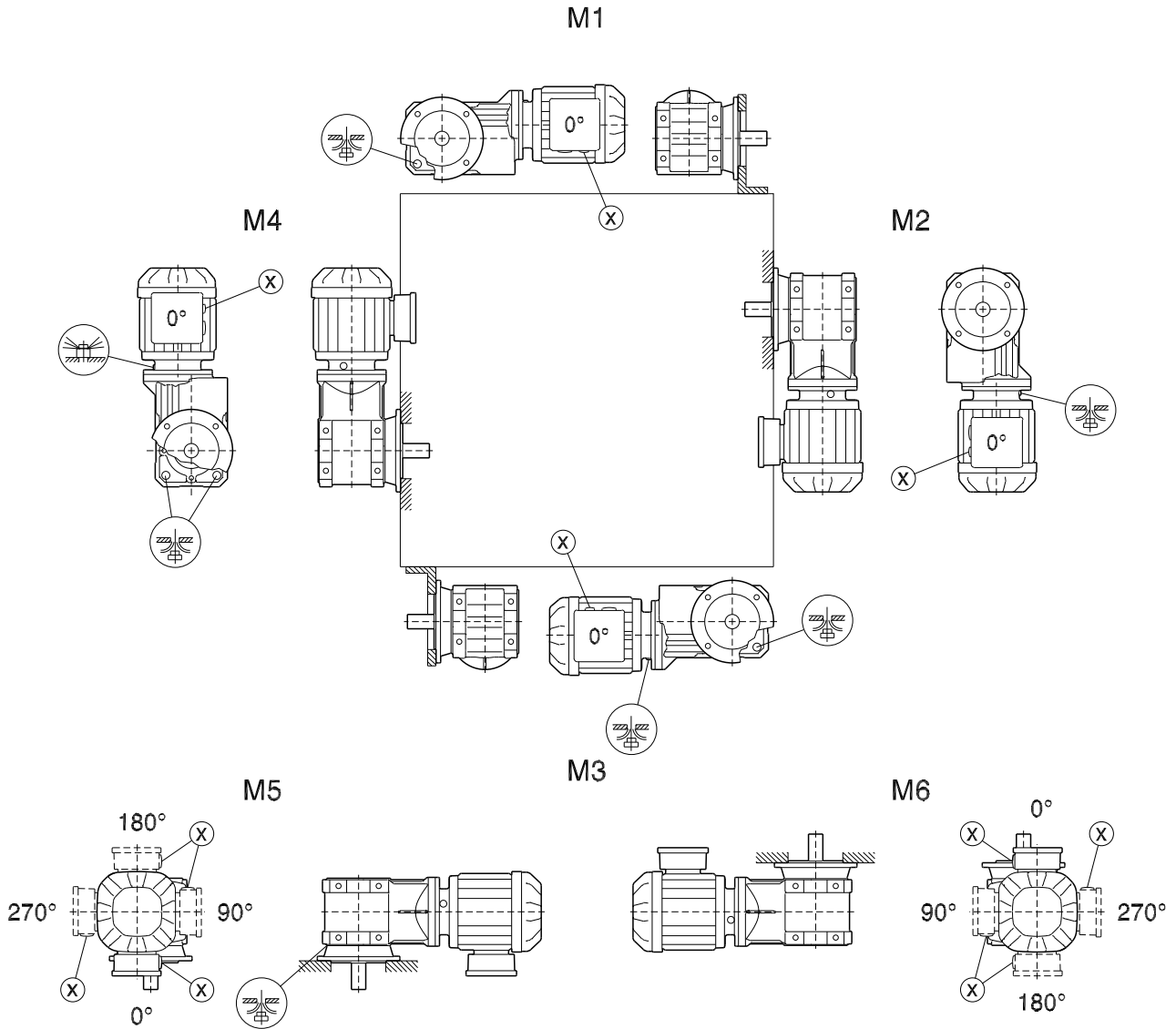
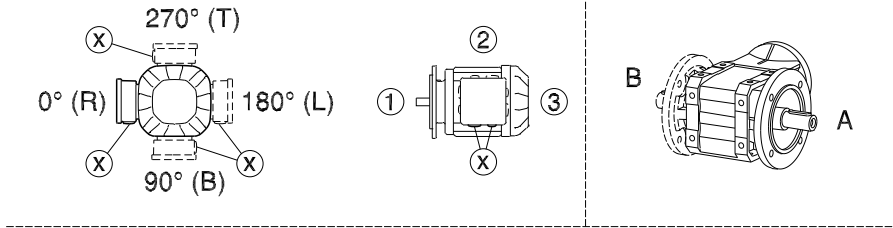

21932786/EN – 05/2015

KA..B/KH19B-29B

33 025 00 15

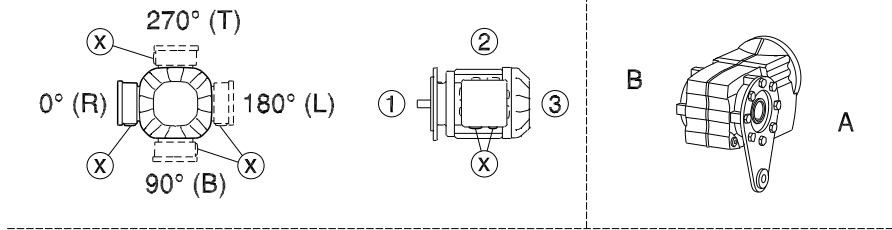

M1

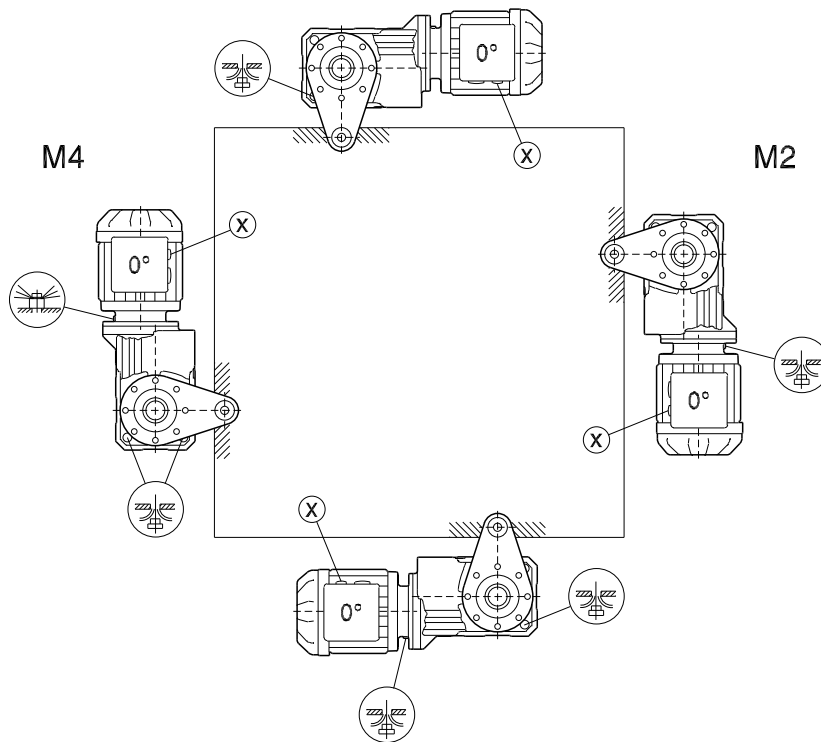

M5

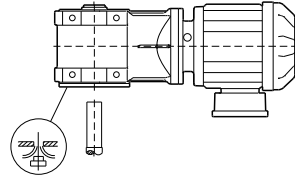
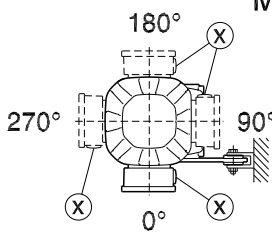

M3

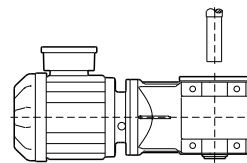

M6

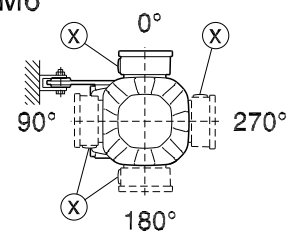

# 7 Mounting positions

Mounting position sheets

KF/KAF/KHF19-29

33 026 00 15

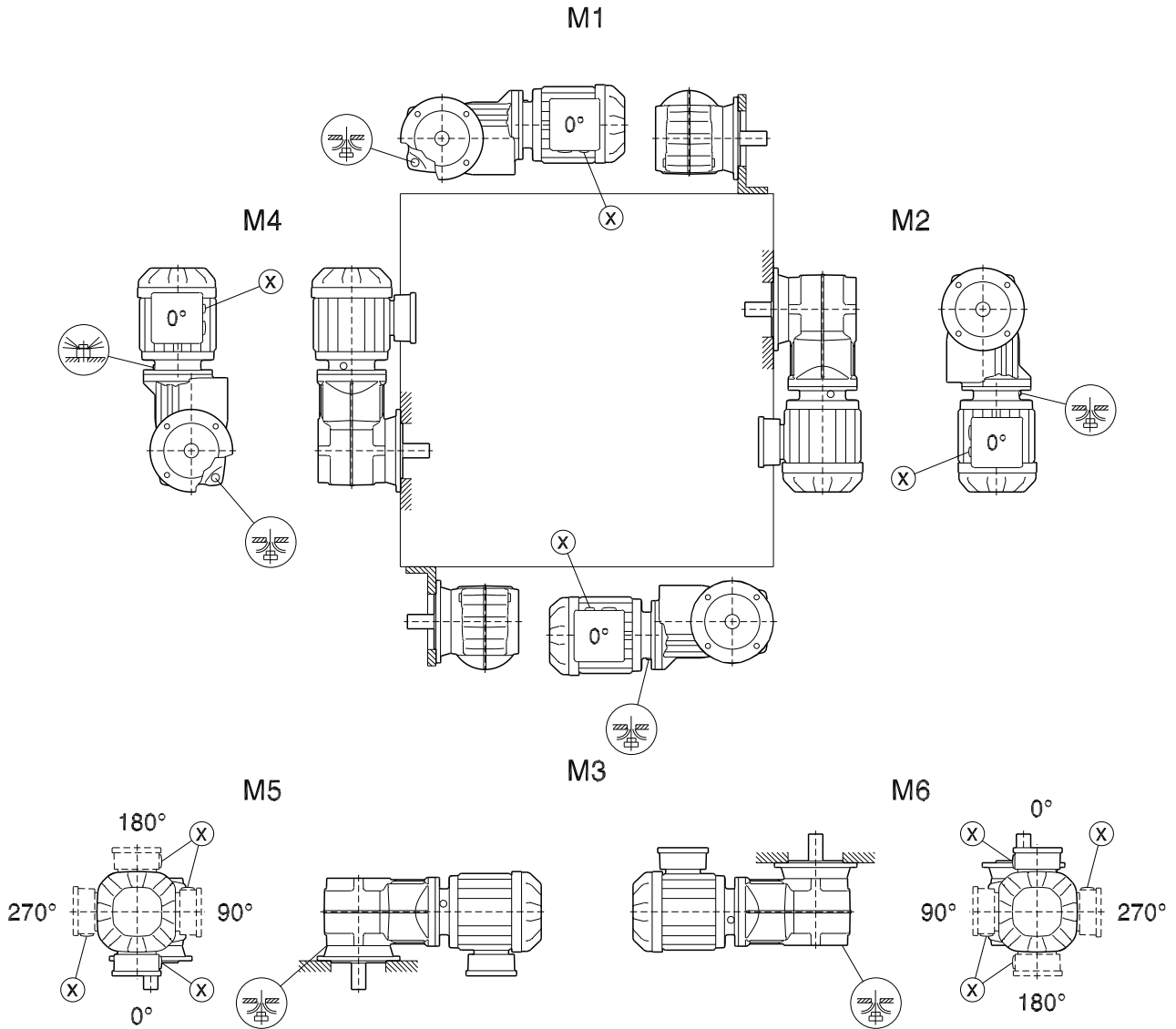
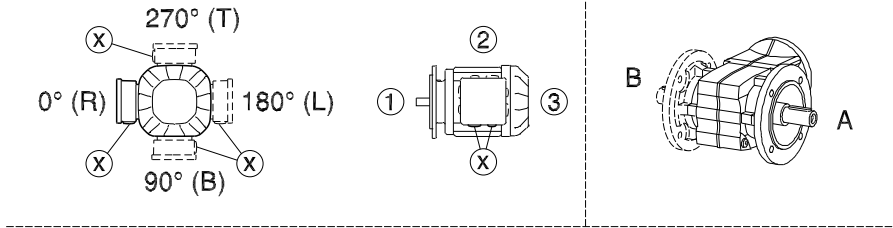

21932786/EN – 05/2015

KA/KH19-29

33 027 00 15

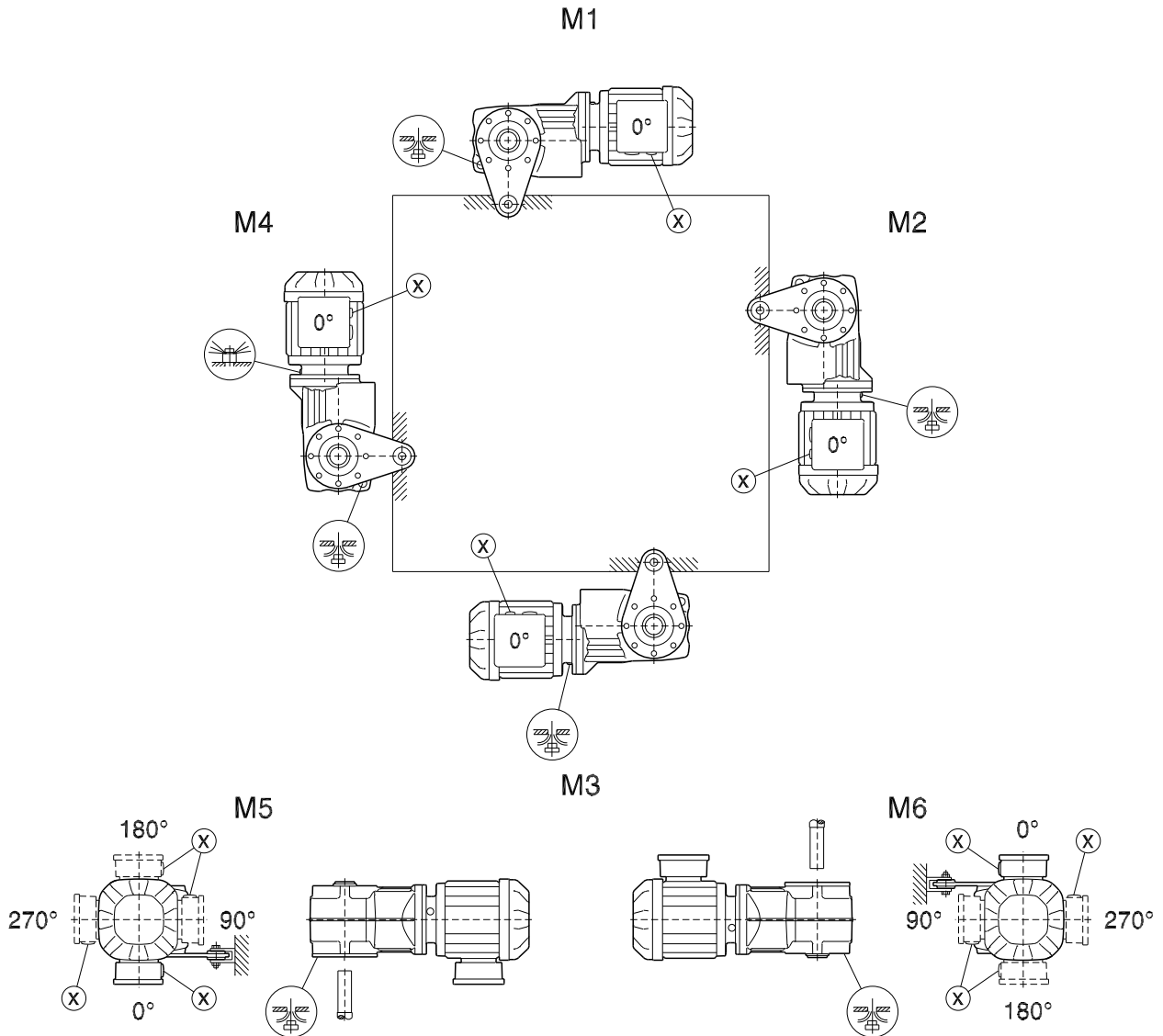
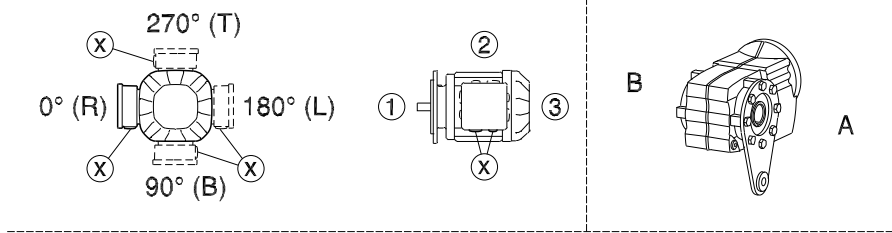

21932786/EN – 05/2015

# 7 Mounting positions



Mounting position sheets

K39-49

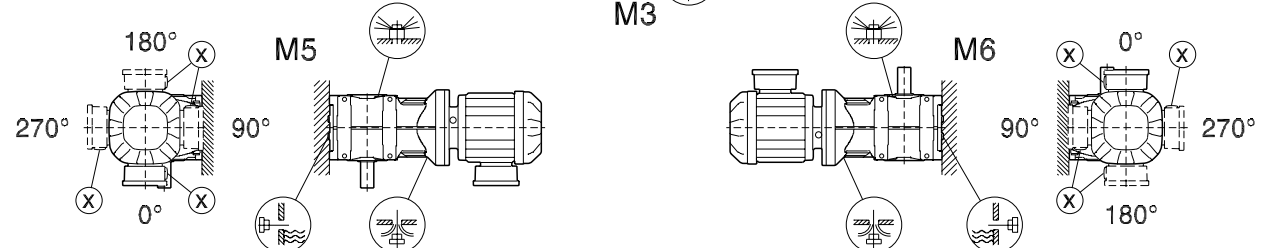
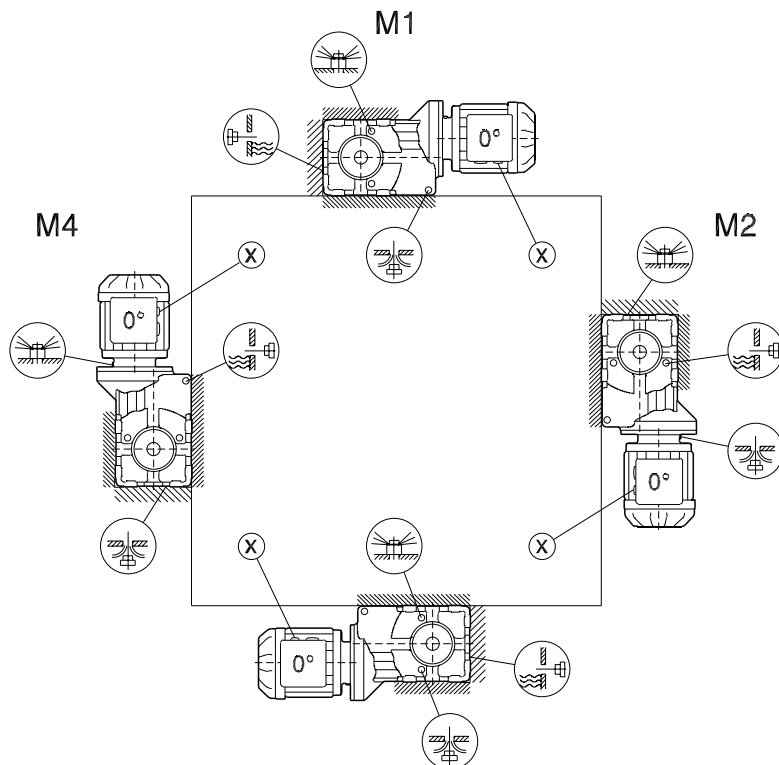
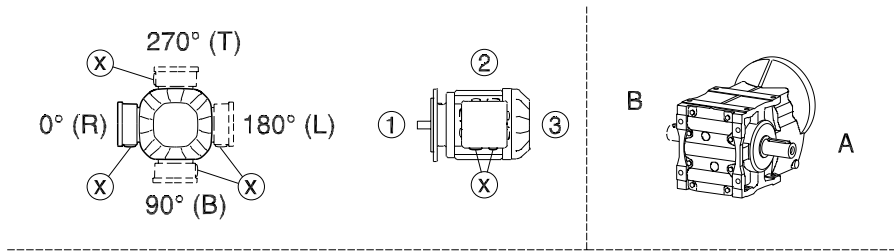
33 092 00 14



For front-end mounting:

-  M2
-  M1, M3, M5, M6
-  M4

21932786/EN – 05/2015

KF/KAF39-49

33 093 00 14

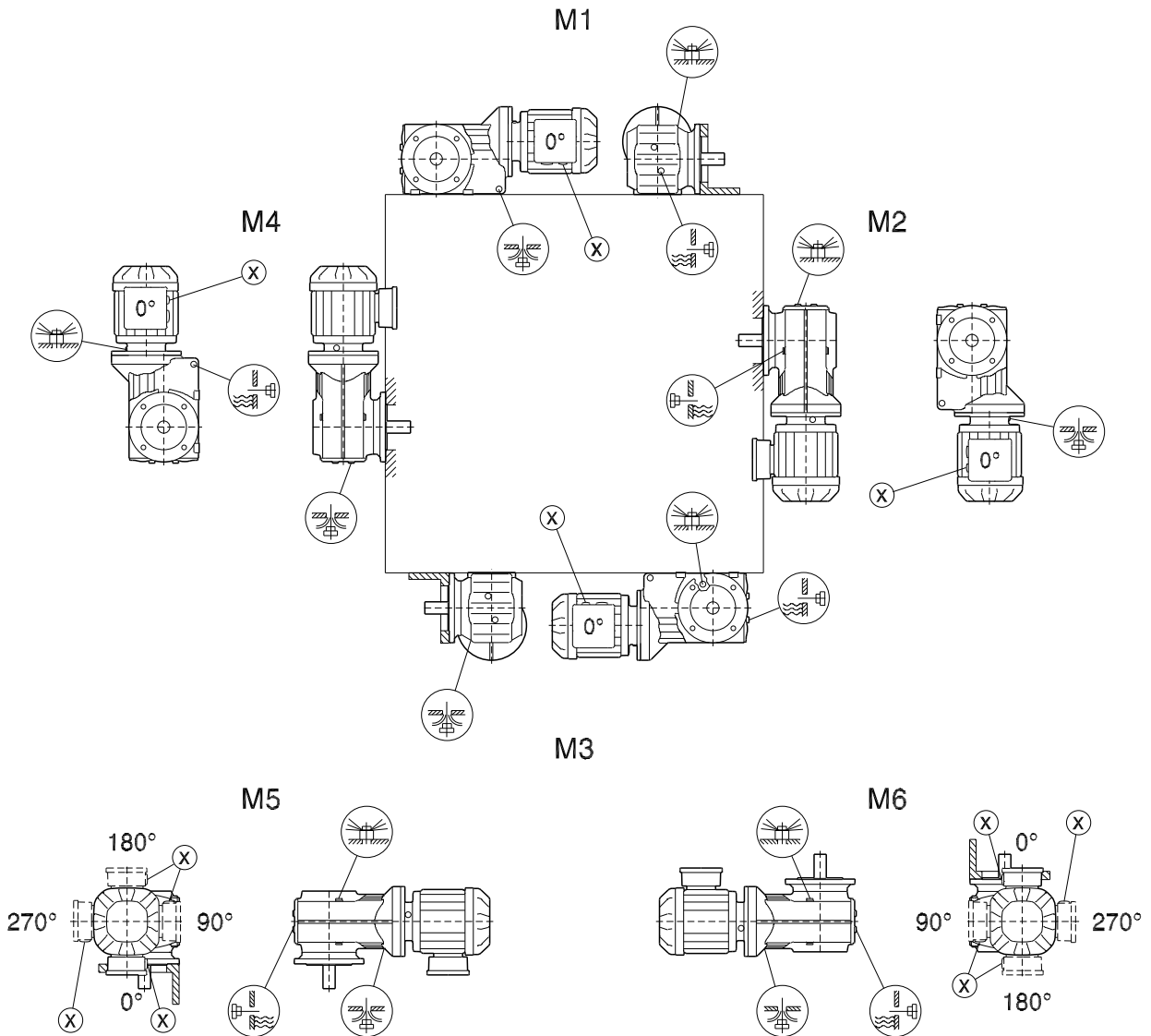
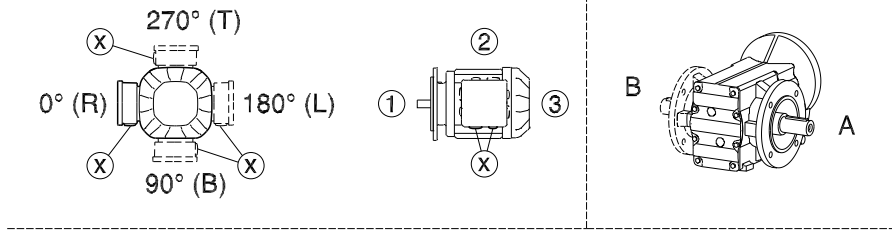

21932786/EN – 05/2015

# 7 Mounting positions

Mounting position sheets

KA/KT39-49

33 094 00 14

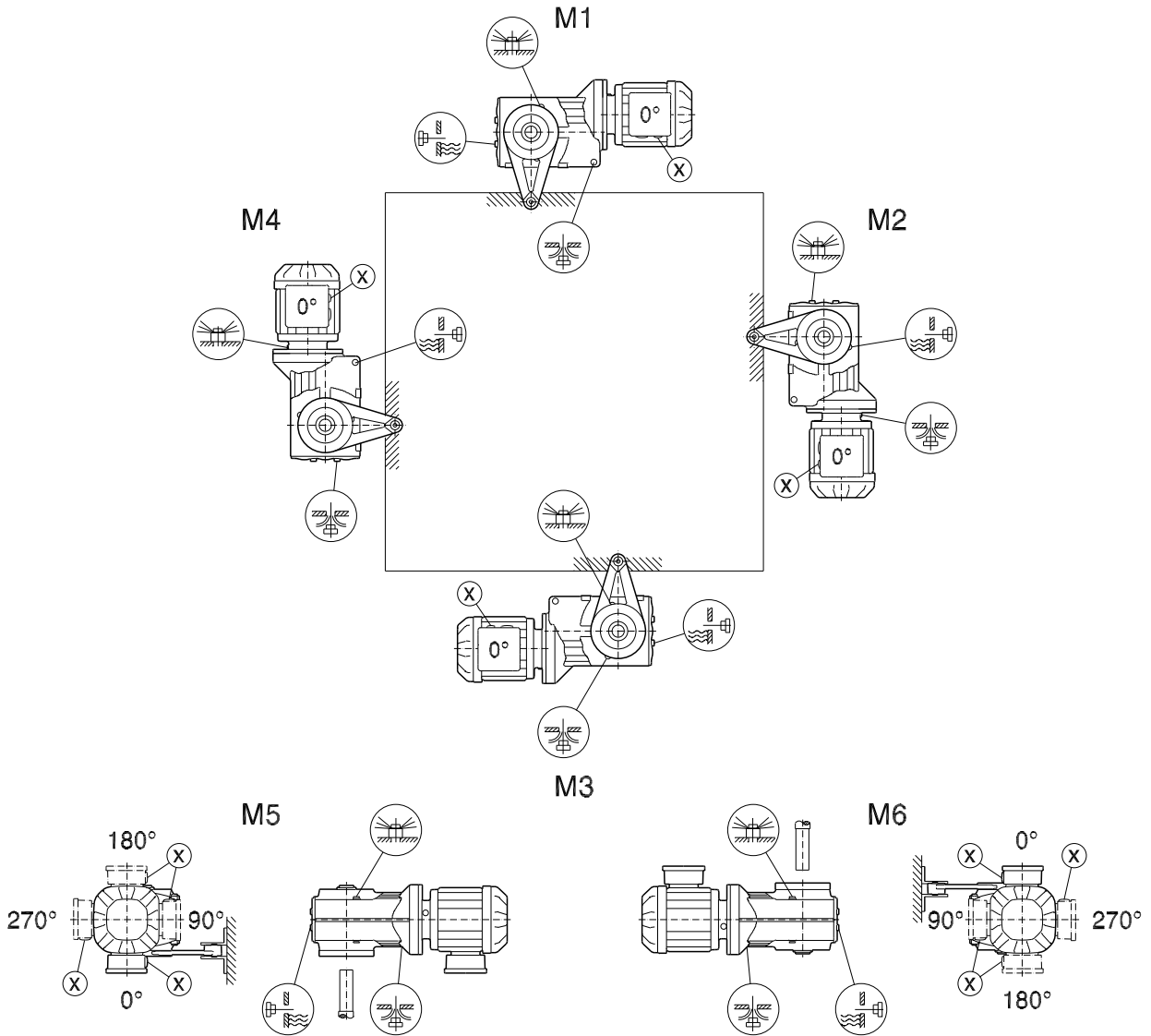
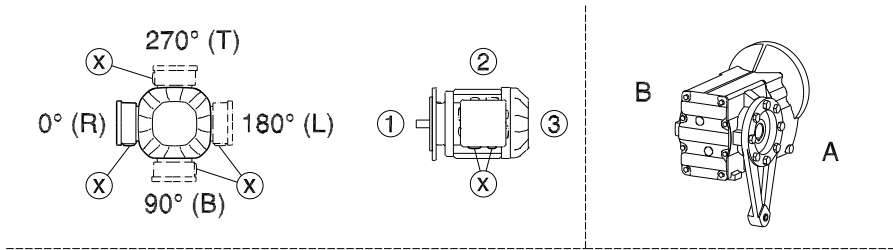

21932786/EN – 05/2015



K/KA..B/KH37B-157B, KV37B-107B

34 025 04 00

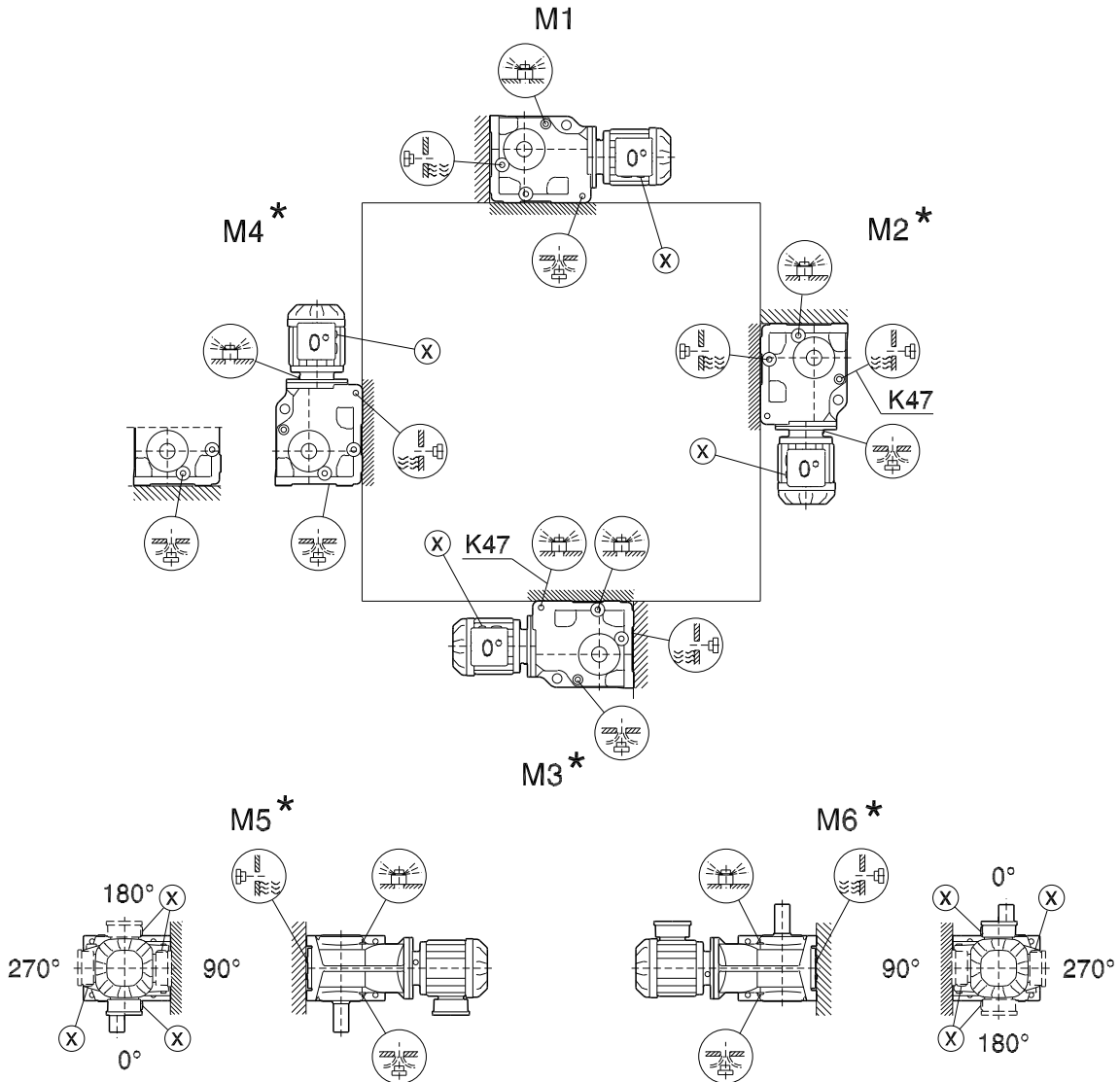
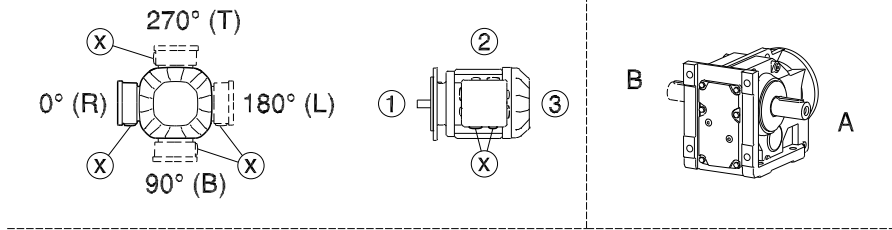

\* (→ 111)

# 7 Mounting positions

Mounting position sheets

K167-187, KH167B-187B

34 026 04 00

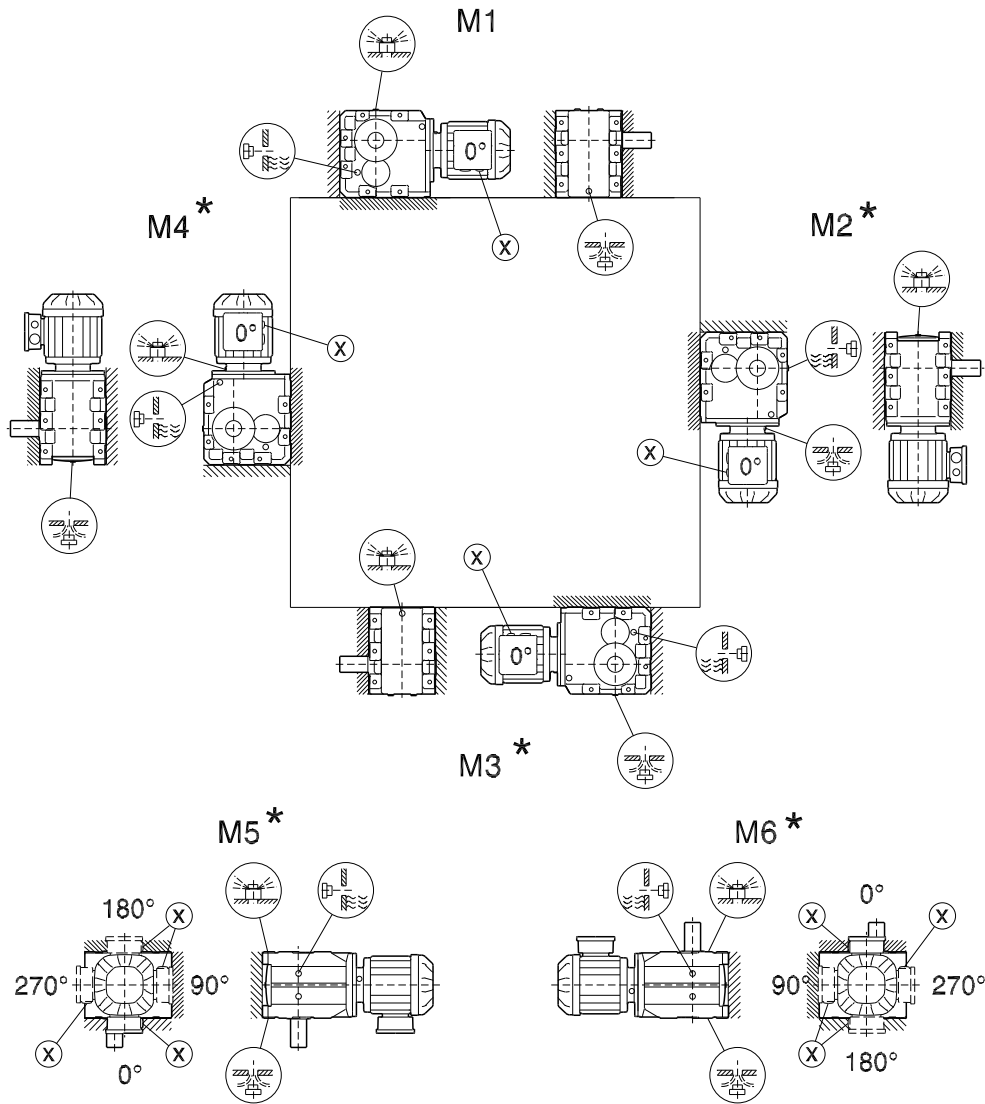
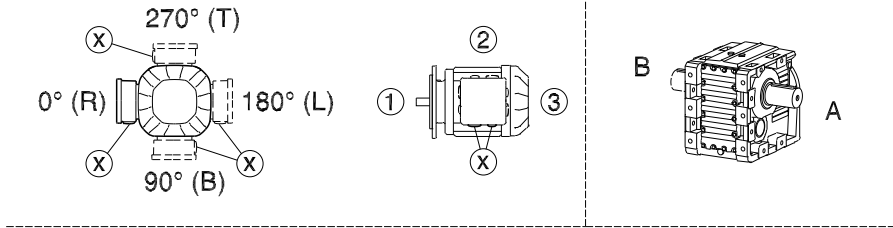

\* (→ 111)

21932786/EN – 05/2015

KF/KAF/KHF/KZ/KAZ/KHZ37-157, KVF/KVZ37-107

34 027 04 00

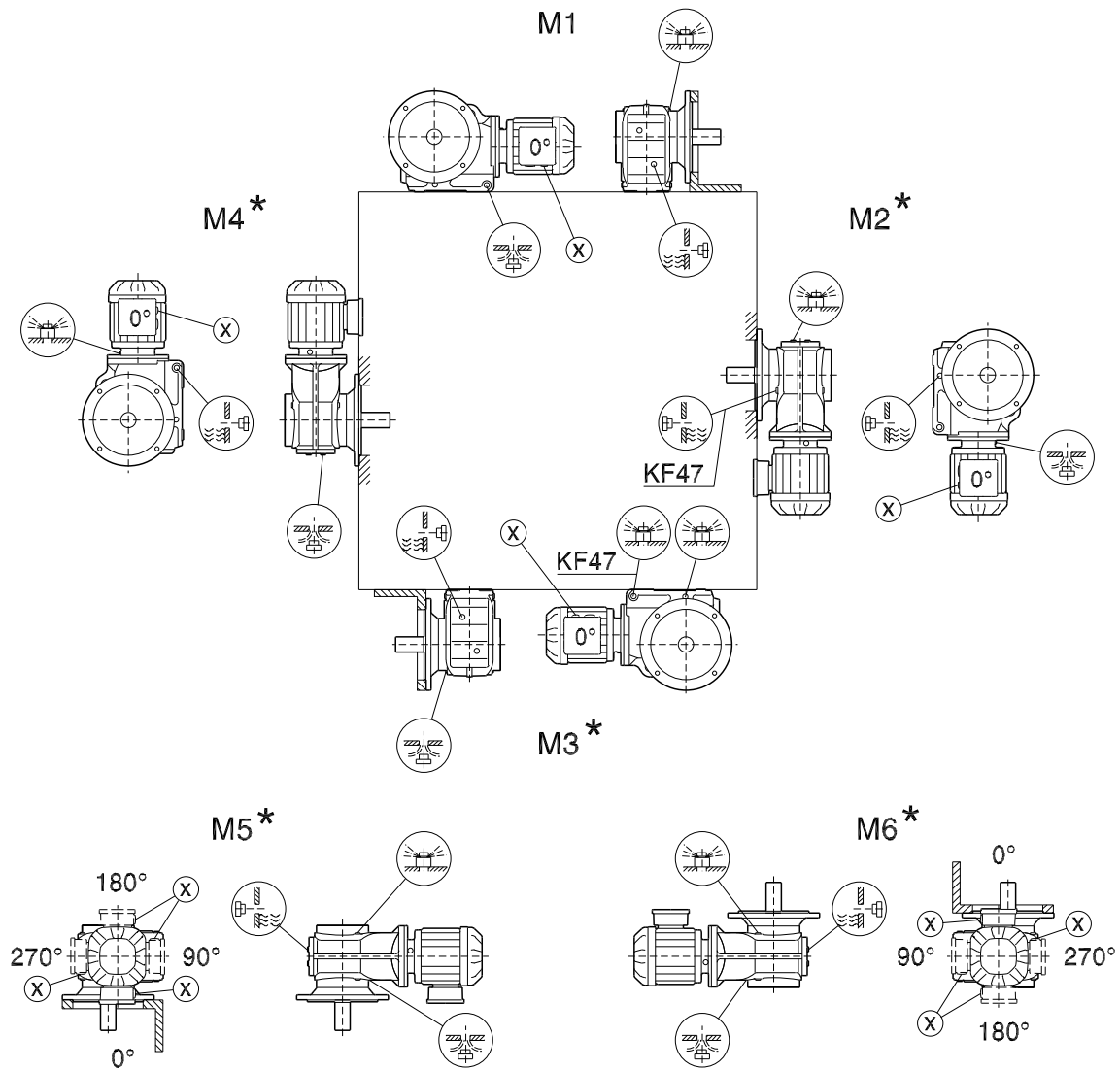
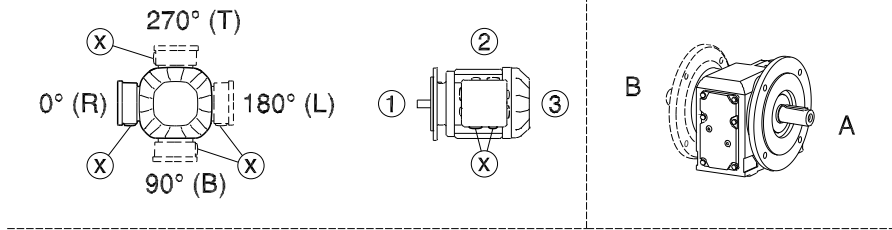

\* (→ 111)

# 7 Mounting positions

Mounting position sheets

KA/KH37-157, KV37-107, KT37-97

39 025 05 00

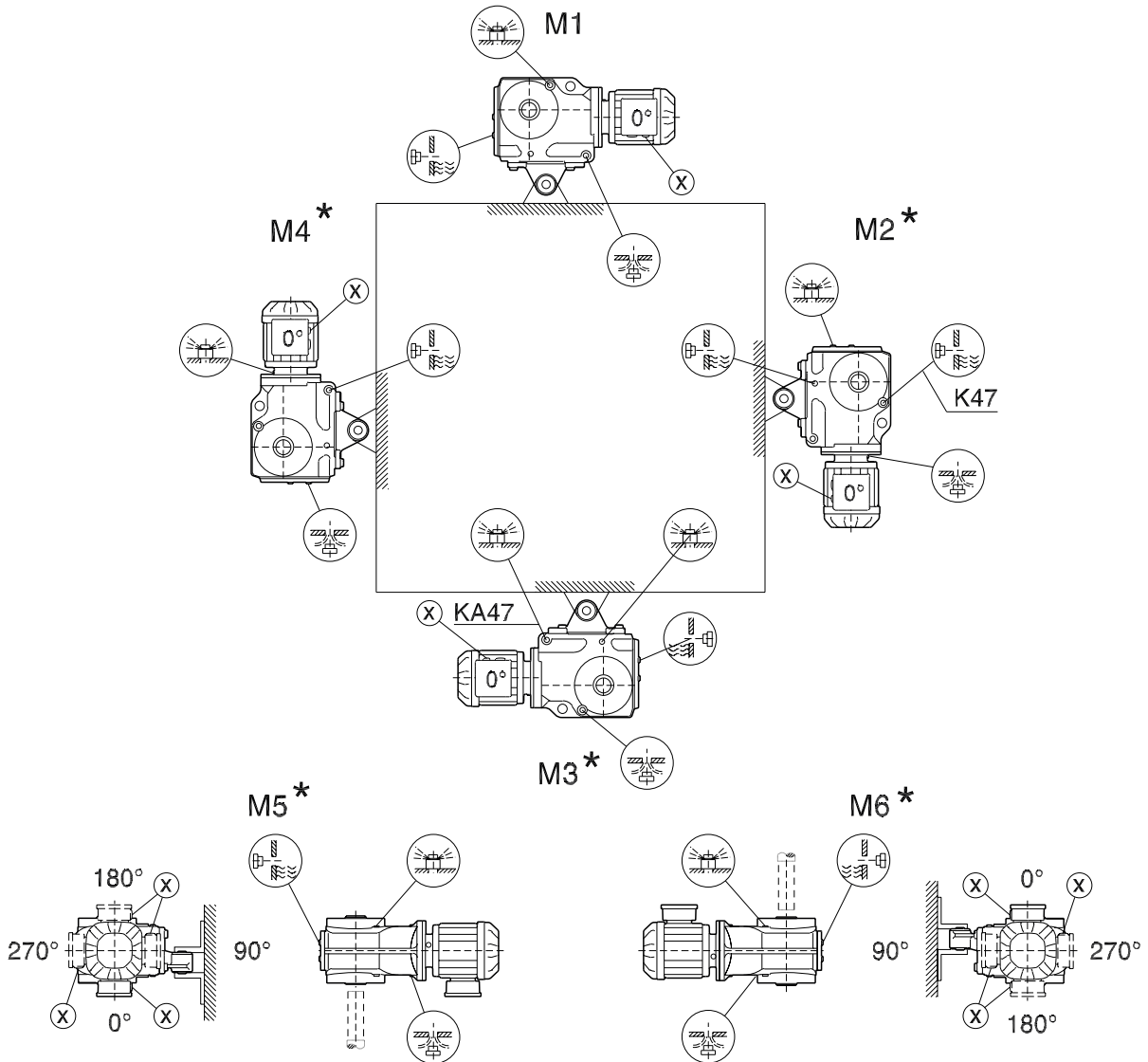
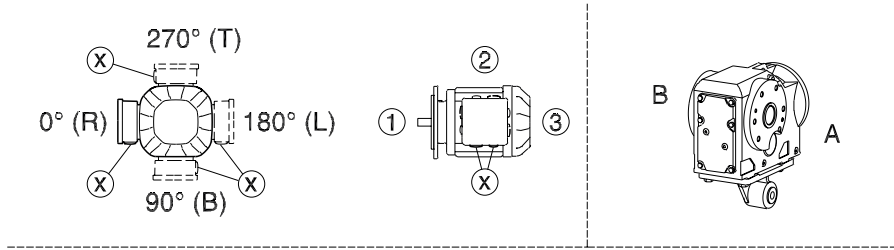

\* (→ 111)

21932786/EN – 05/2015

KH167-187

39 026 05 00

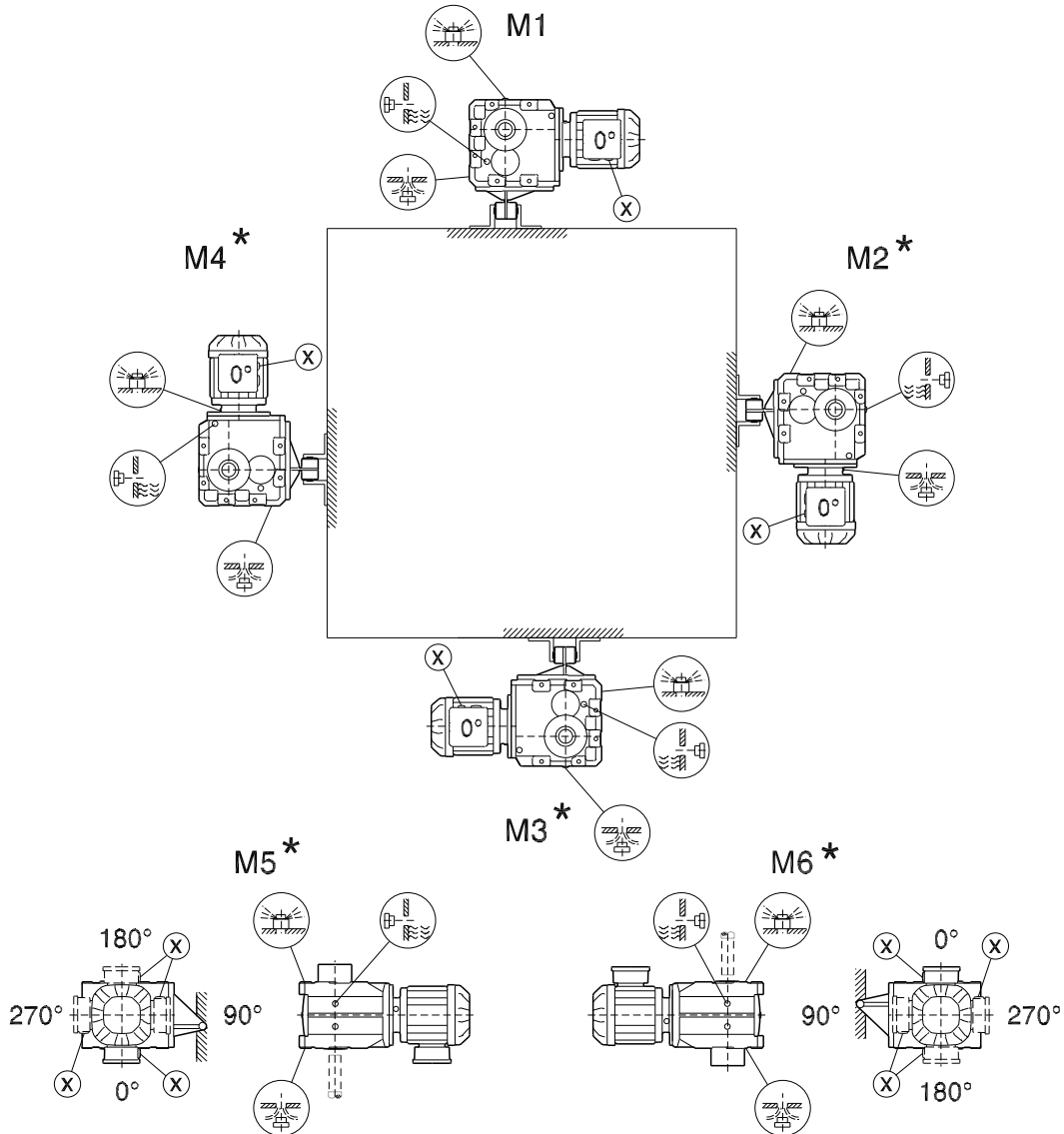
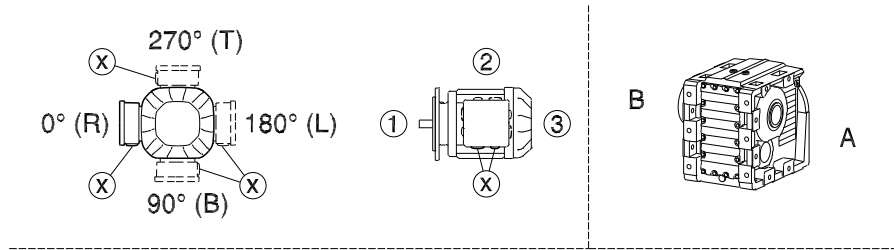

\* (→ 111)

21932786/EN – 05/2015

# 7 Mounting positions

Mounting position sheets

## 7.6.5 Mounting positions of helical-worm gearmotors

S37

05 025 04 00

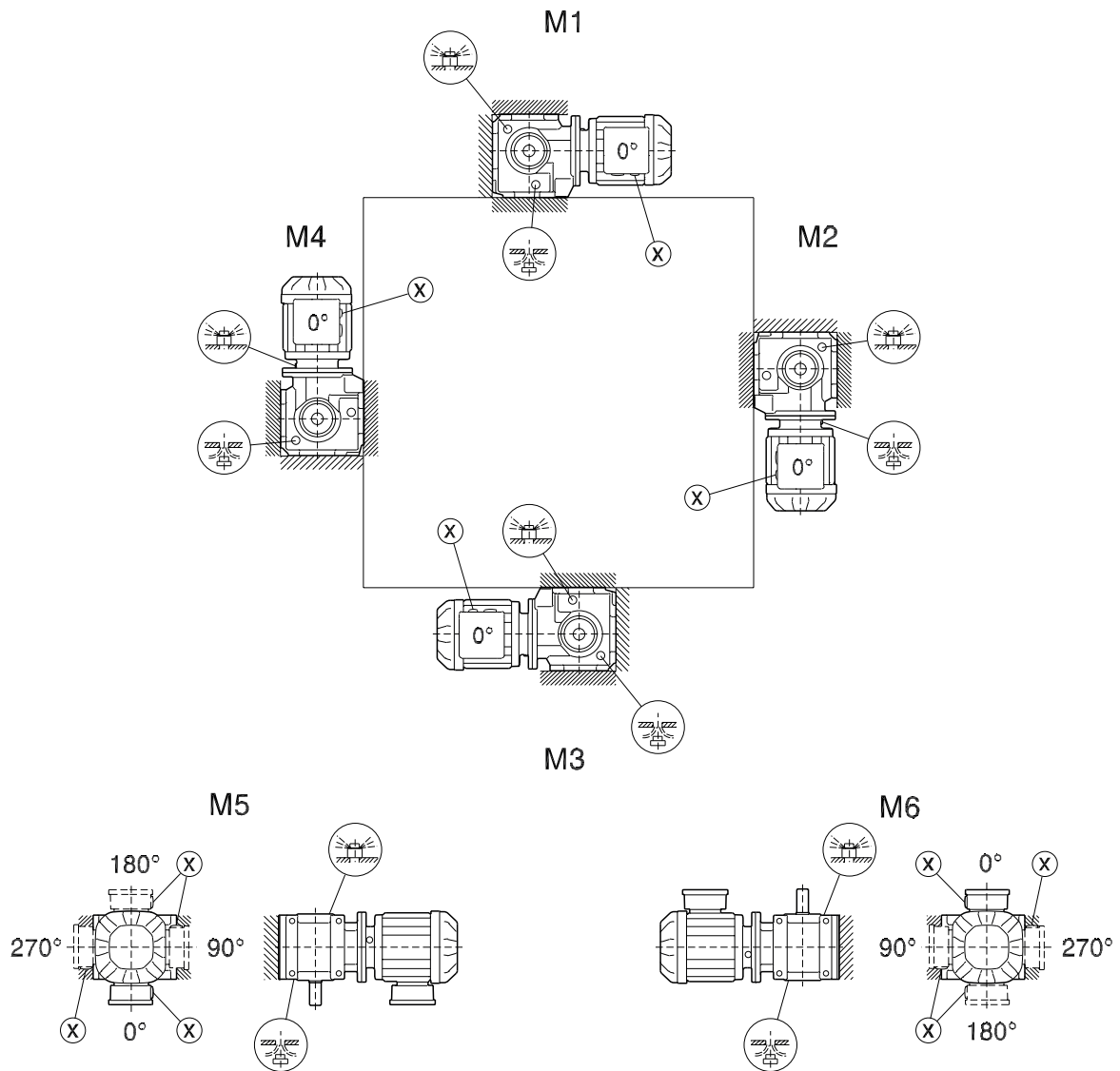
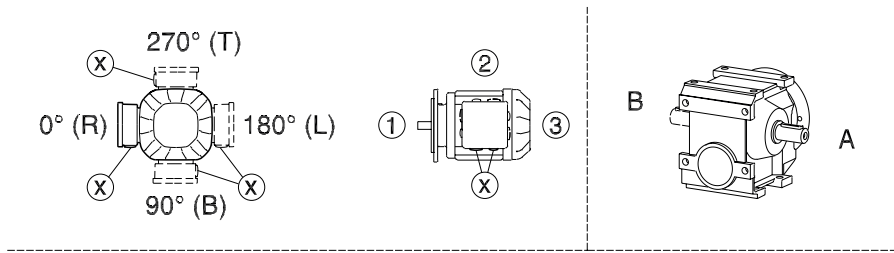

21932786/EN – 05/2015

S47-S97

05 026 04 00

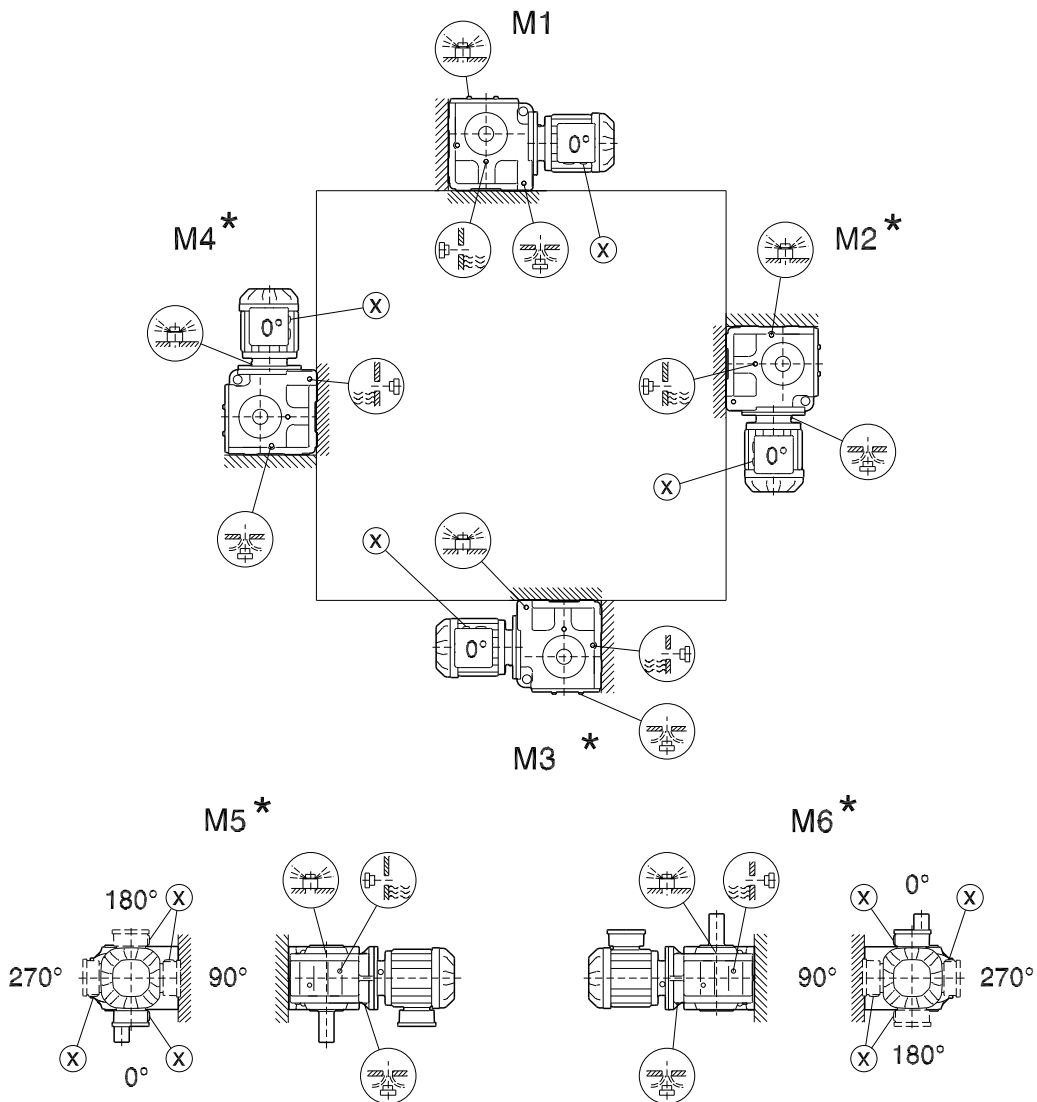
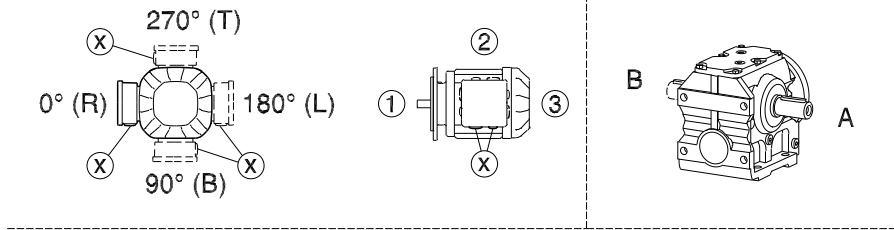

\* (→ 111)

21932786/EN – 05/2015

# 7 Mounting positions

Mounting position sheets

SF/SAF/SHF37

05 027 04 00

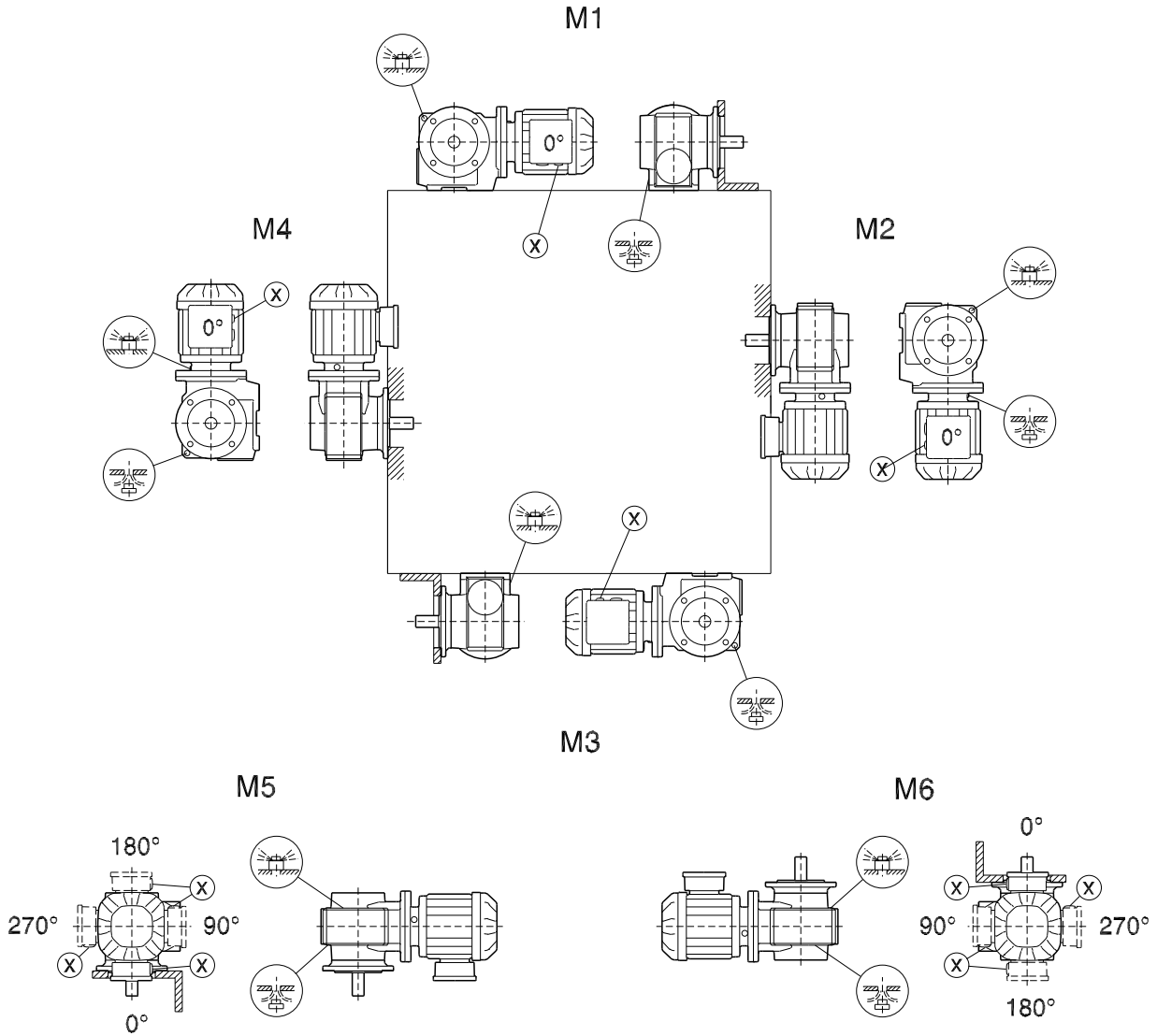
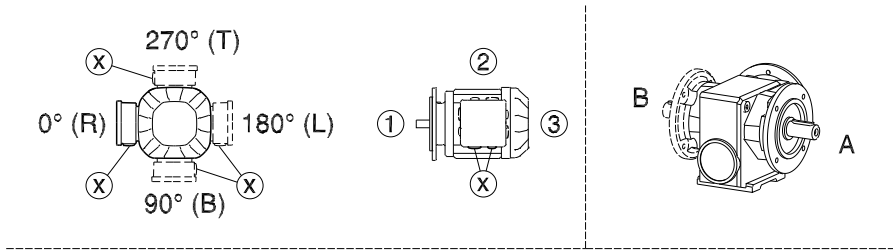

21932786/EN – 05/2015



SF/SAF/SHF/SAZ/SHZ47-97

05 028 04 00

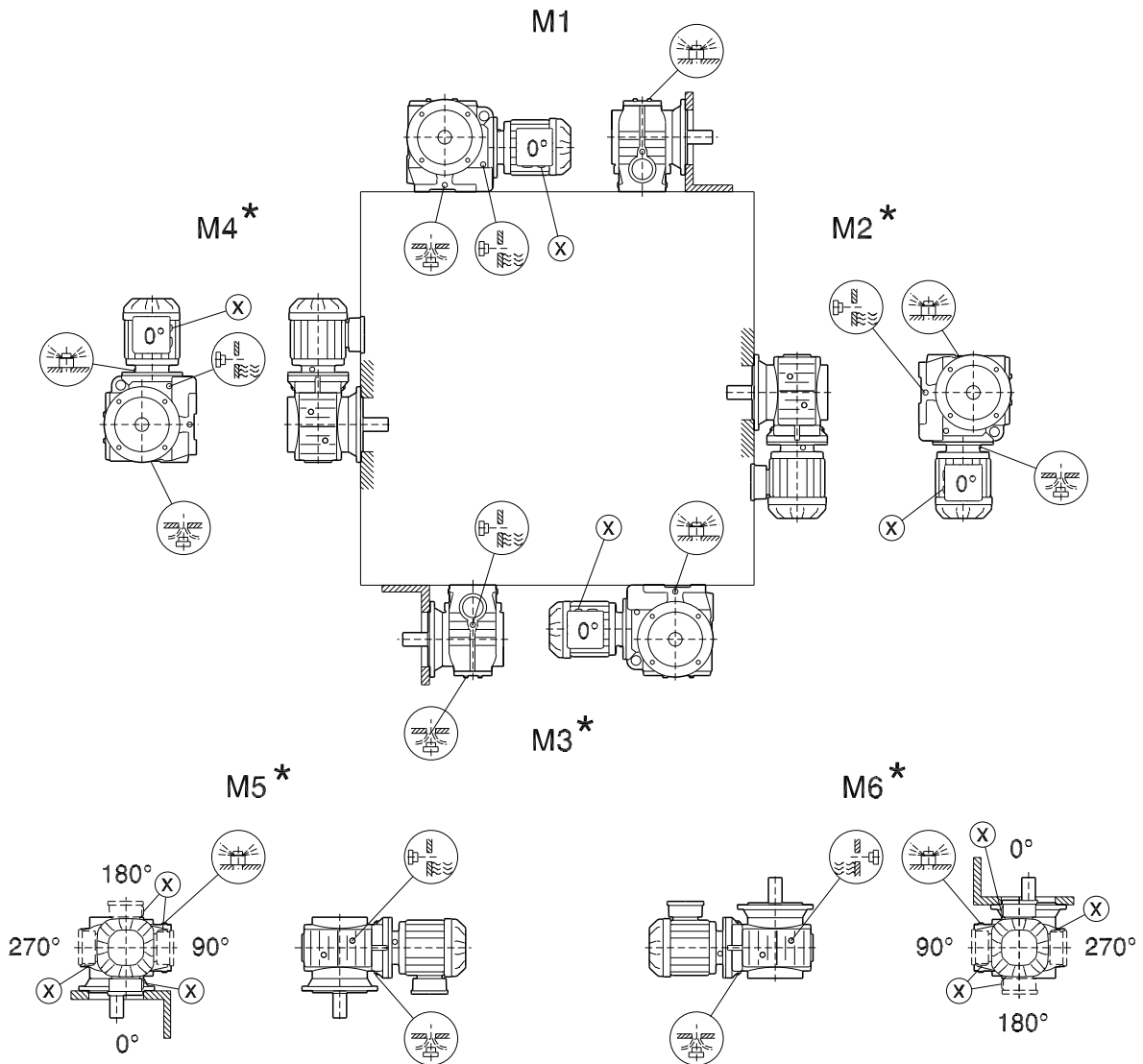
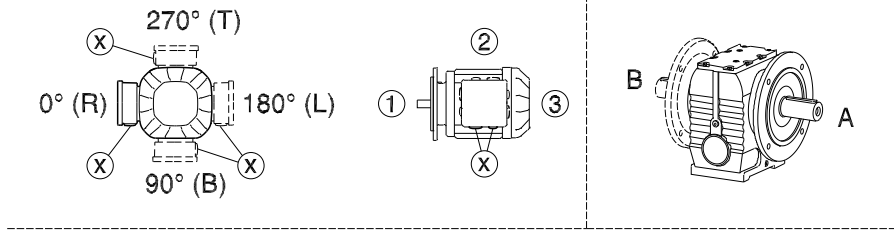

\* (→ 111)

# 7 Mounting positions

Mounting position sheets

SA/SH/ST37

28 020 05 00

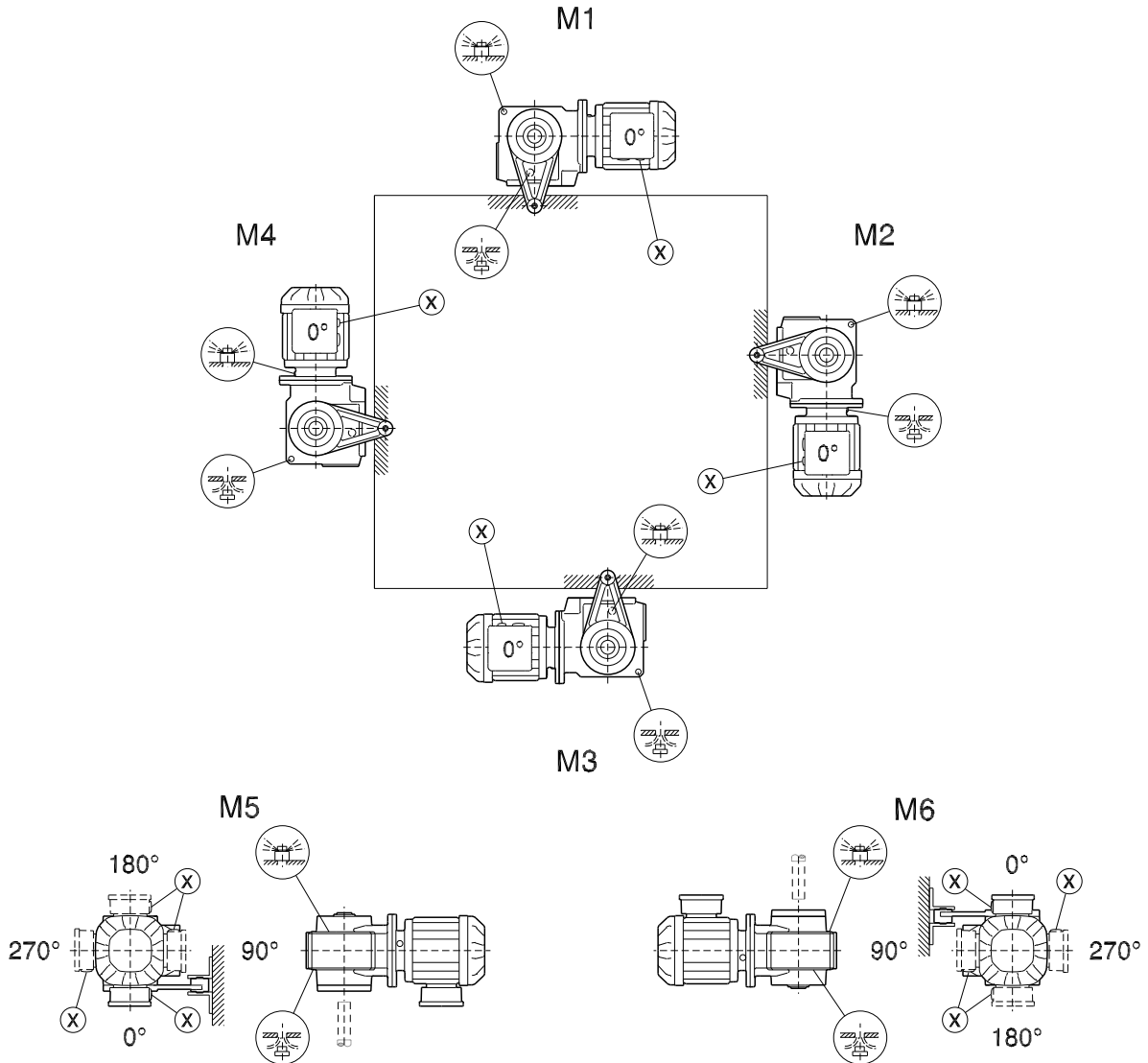
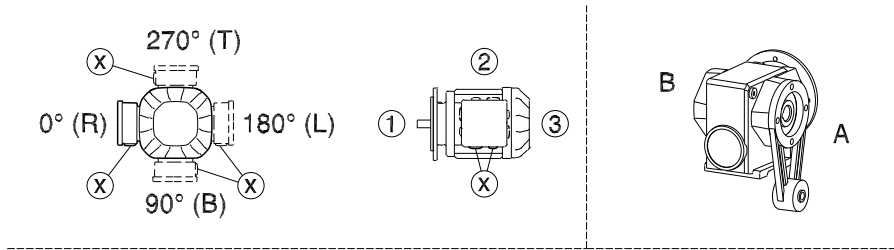

21932786/EN – 05/2015

SA/SH/ST47-97

28 021 04 00

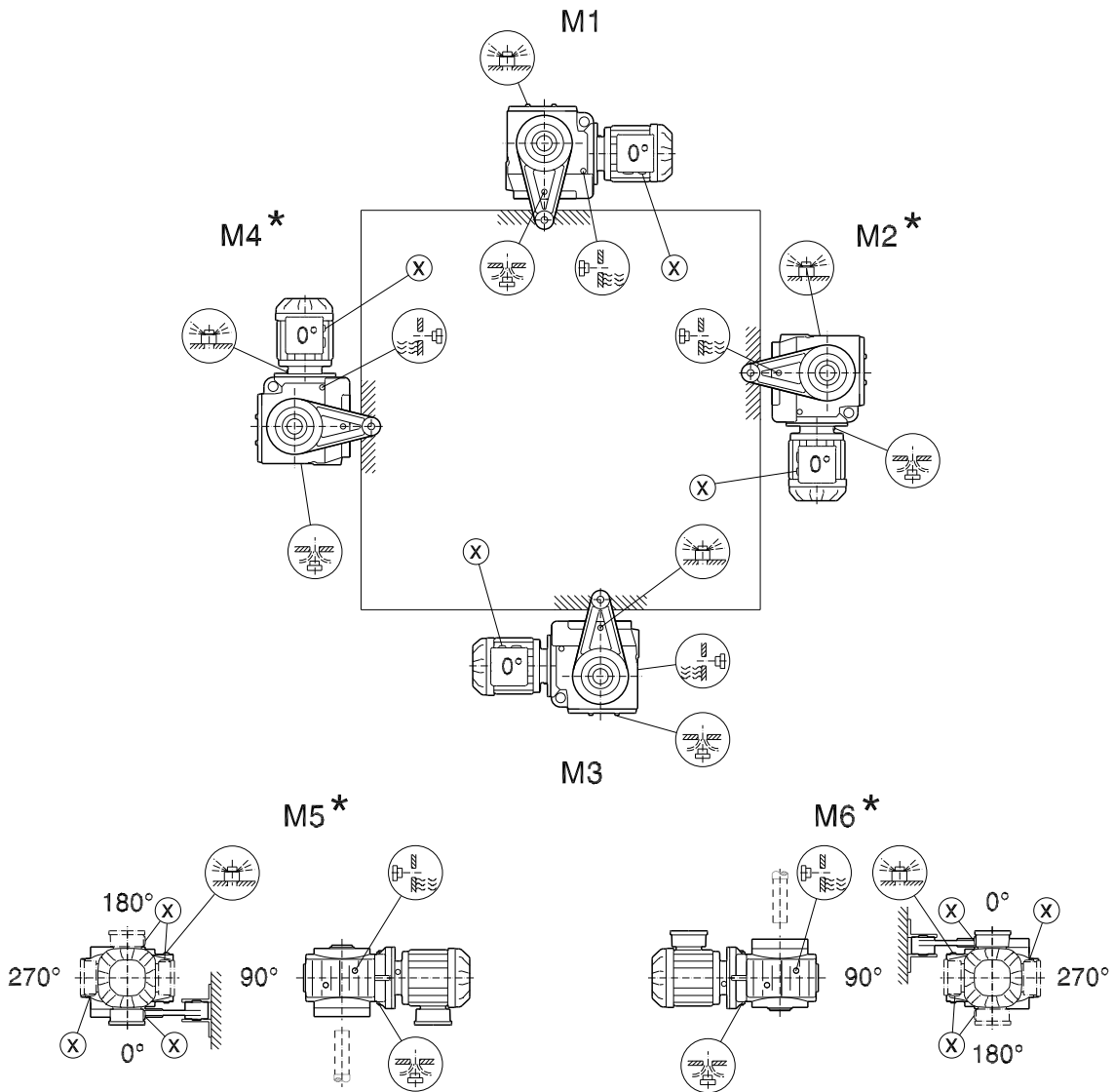
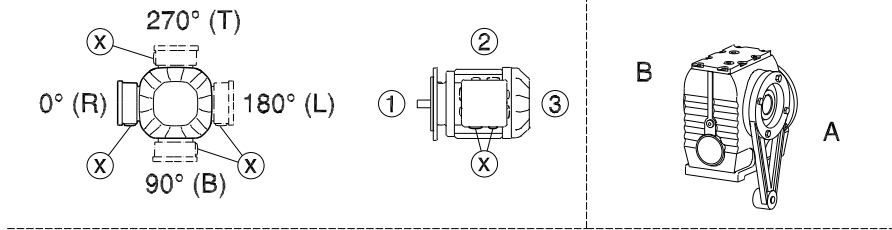

\* (→ 111)

21932786/EN – 05/2015

# 7 Mounting positions

Mounting position sheets

## 7.6.6 Mounting positions of SPIROPLAN® gearmotors

W10-30

20 001 02 02

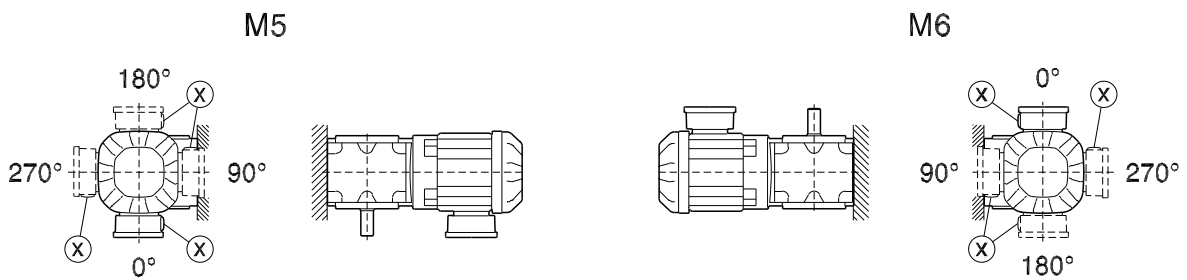
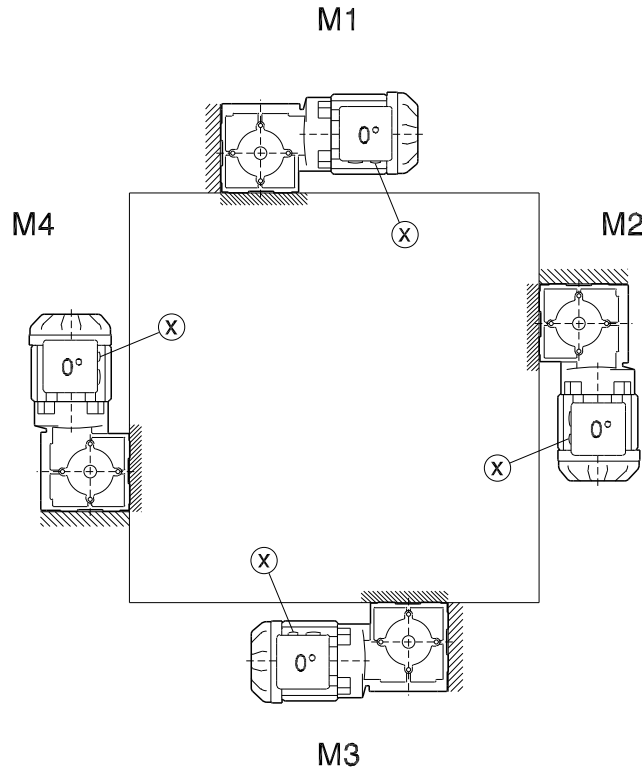
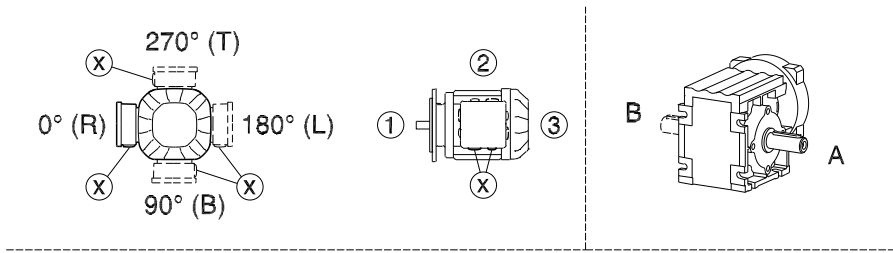

21932786/EN – 05/2015

WF10-30

20 002 02 02

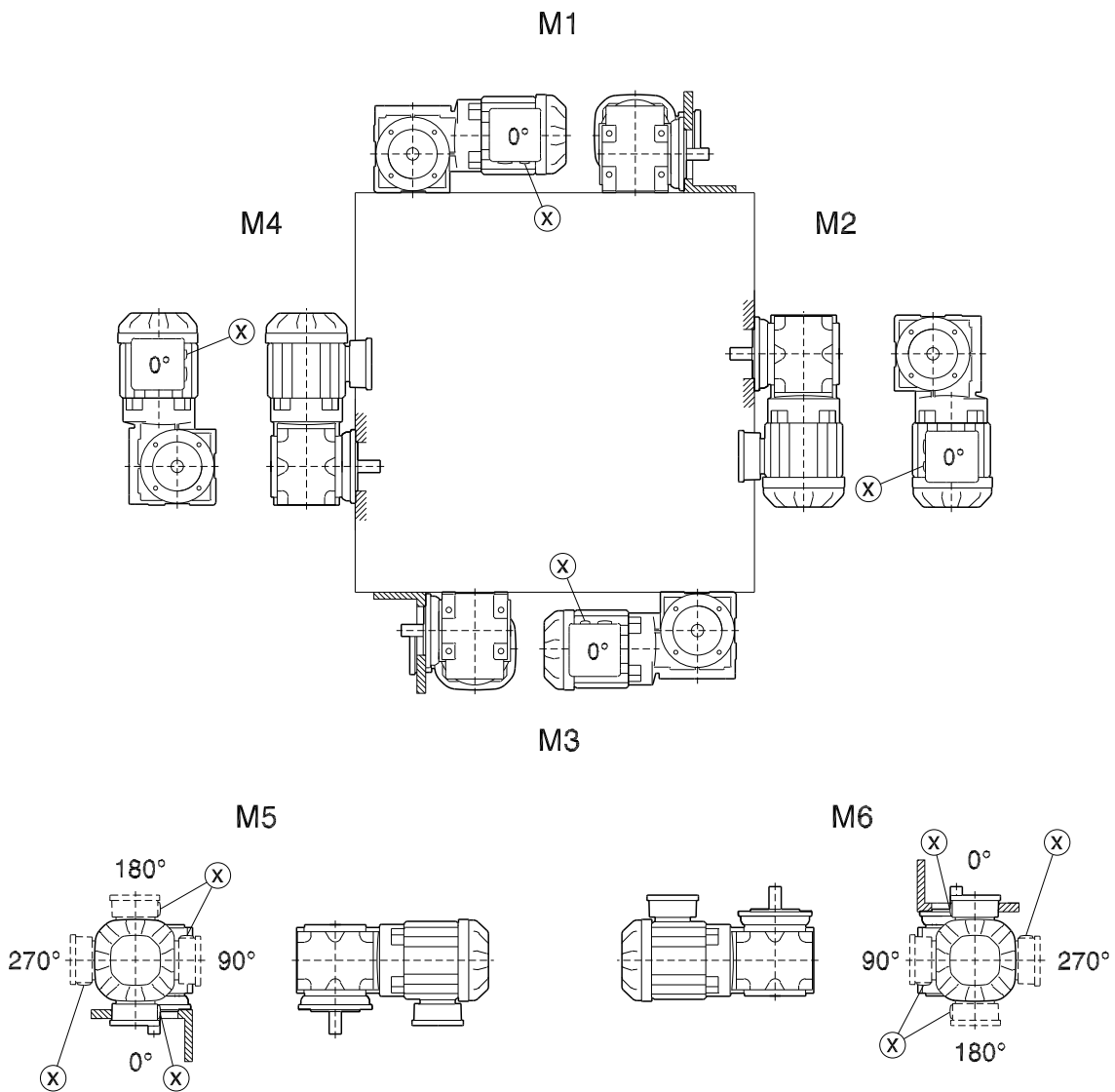
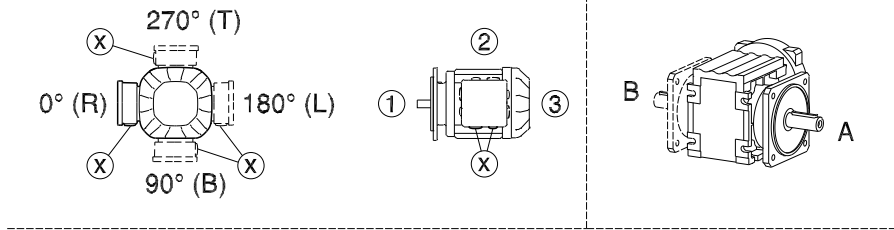

21932786/EN – 05/2015

# 7 Mounting positions

Mounting position sheets

WA10-30

20 003 03 02

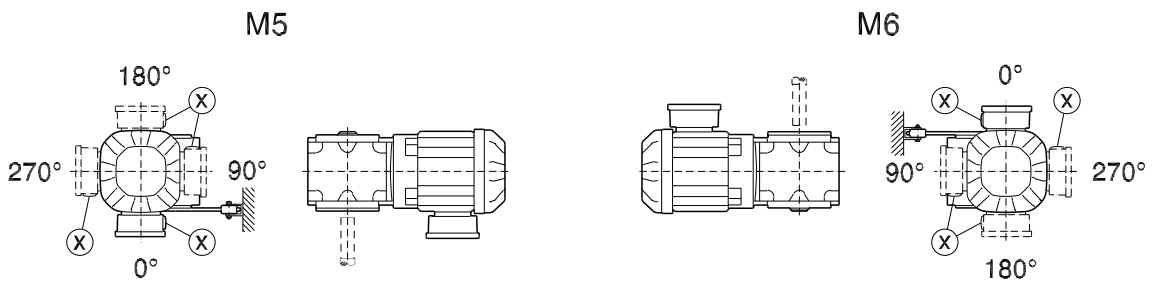
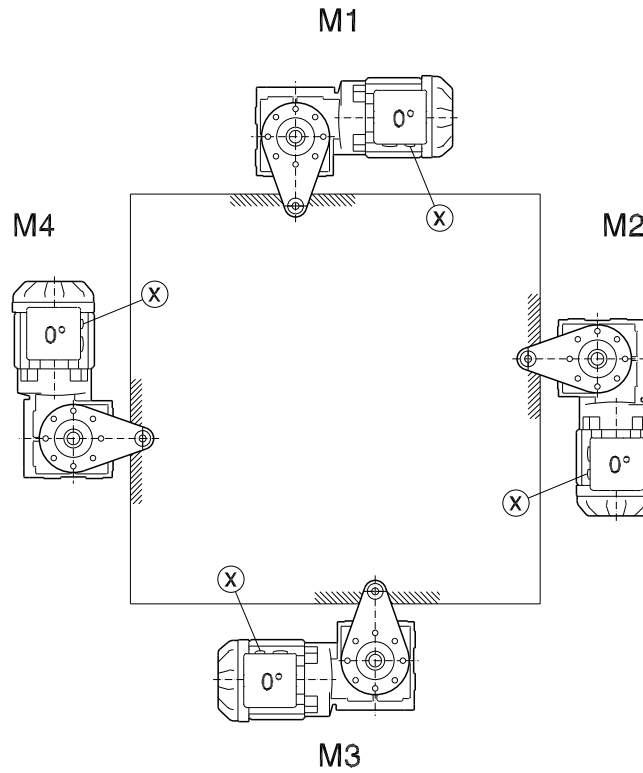
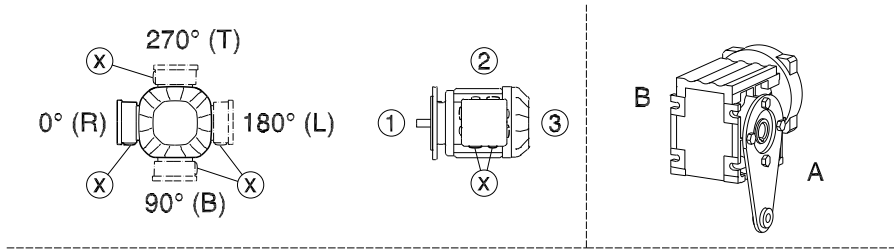

21932786/EN – 05/2015

W/WA..B/WH37B-47B

20 012 02 07

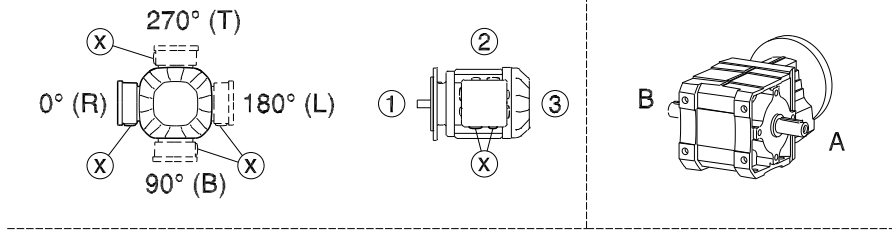

M1

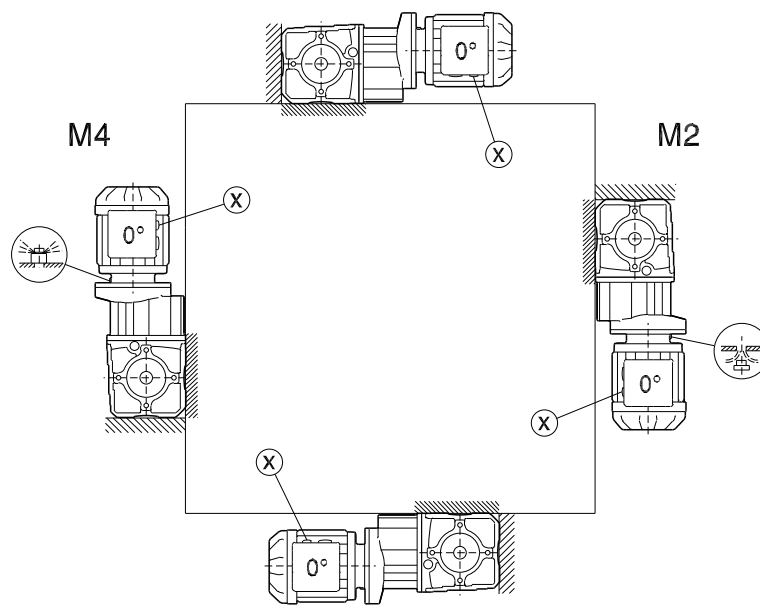

M3

M5

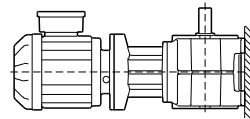
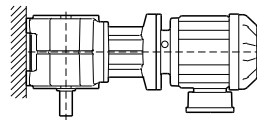
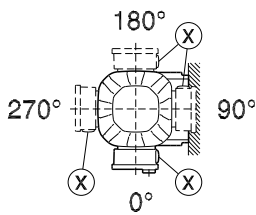

M6

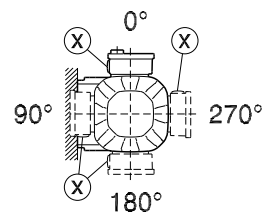

# 7 Mounting positions

Mounting position sheets

WF/WAF/WHF37-47

20 013 02 07

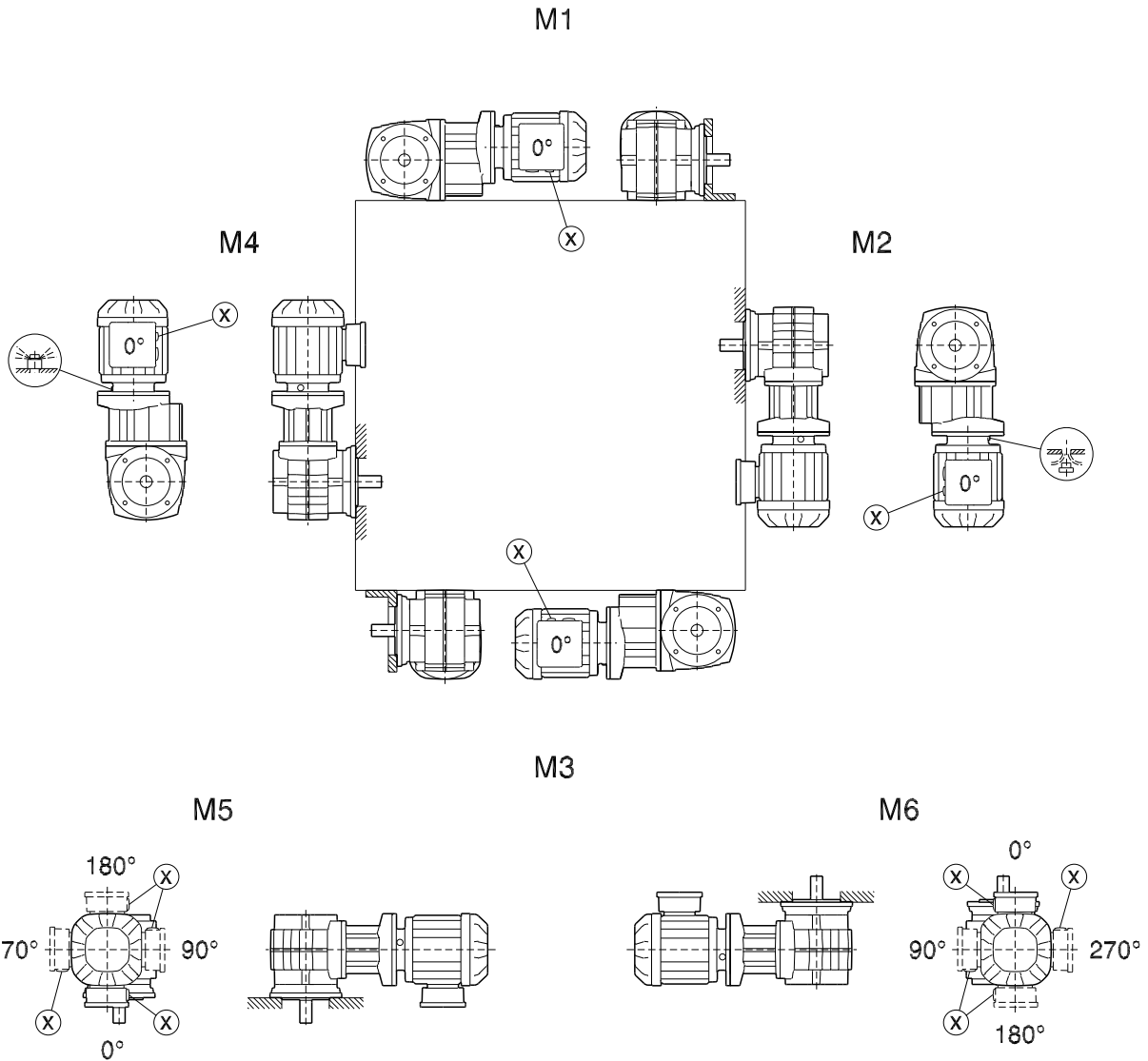
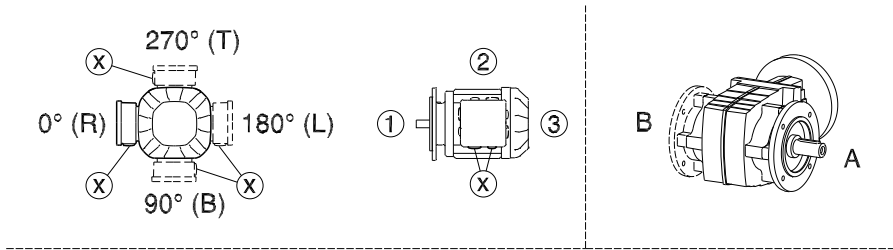

21932786/EN – 05/2015



WA/WH/WT37-47

20 014 02 07

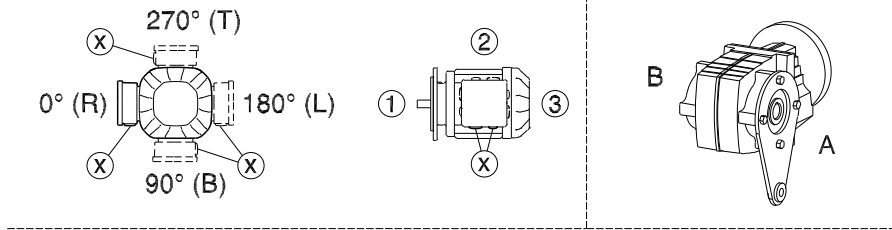

M1

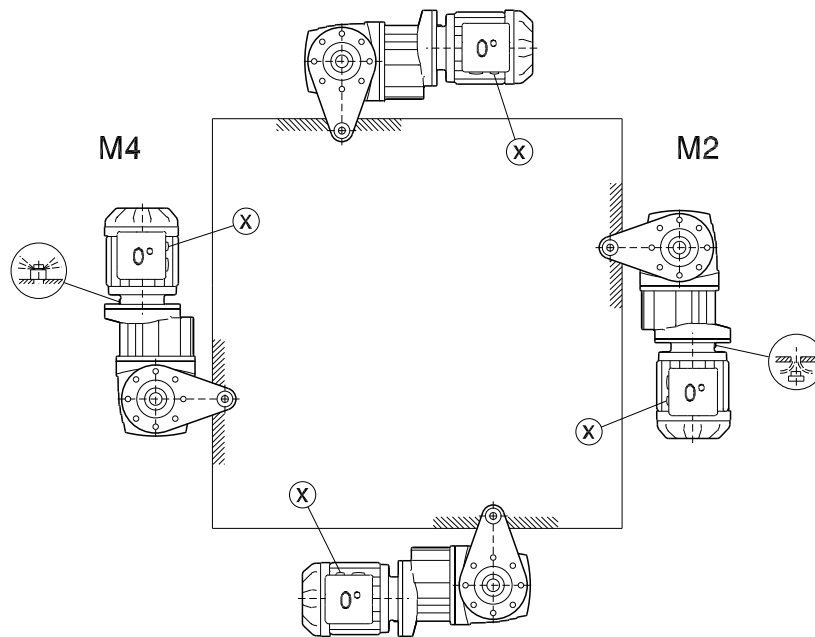

M3

M5

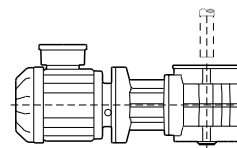
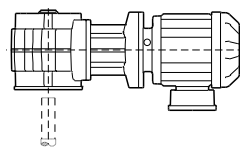
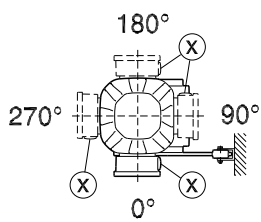

M6

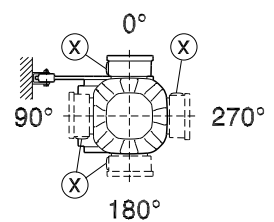

21932786/EN – 05/2015

## 8 Technical data

### 8.1 Extended storage

#### INFORMATION



For storage periods longer than 9 months, SEW-EURODRIVE recommends the "extended storage" gear unit type. Gear units in this design are designated with a corresponding label.

For gear units of the "extended storage" design, the following measures are taken:

- A VCI anti-corrosion agent (volatile corrosion inhibitors) is added to the lubricant.

Please note that this VCI anti-corrosion agent is only effective in a temperature range of -25 °C to +50 °C.

- The flange contact surfaces and shaft ends are also treated with an anti-corrosion agent.

Observe the storage conditions specified in the following table for extended storage.

#### 8.1.1 Storage conditions

Observe the storage conditions specified in the following table for extended storage:

Climate zone	Packaging <sup>1)</sup>	Storage <sup>2)</sup>	Storage duration
Temperate (Europe, USA, Canada, China and Russia, excluding tropical zones)	<ul style="list-style-type: none"> <li>• Packed in containers</li> <li>• With desiccant and moisture indicator sealed in the plastic wrap</li> </ul>	<ul style="list-style-type: none"> <li>• Roofed</li> <li>• Protected against rain and snow</li> <li>• Shock-free</li> </ul>	Up to 3 years with regular checks of the packaging and moisture indicator (rel. humidity < 50%)
	Open	<ul style="list-style-type: none"> <li>• Under roof and enclosed at constant temperature and atmospheric humidity (5 °C &lt; <math>\vartheta</math> &lt; 50 °C, &lt; 50% relative humidity)</li> <li>• No sudden temperature variations</li> <li>• Controlled ventilation with filter (free from dust and dirt)</li> <li>• No aggressive vapors</li> <li>• No shocks</li> </ul>	2 years or more with regular inspections <ul style="list-style-type: none"> <li>• Check for cleanness and mechanical damage during the inspection</li> <li>• Check corrosion protection</li> </ul>

Climate zone	Packaging <sup>1)</sup>	Storage <sup>2)</sup>	Storage duration
Tropical (Asia, Africa, Central and South America, Australia, New Zealand excluding temperate zones)	<ul style="list-style-type: none"> <li>• Packed in containers</li> <li>• With desiccant and moisture indicator sealed in the plastic wrap</li> <li>• Protected against insect damage and mildew by chemical treatment</li> </ul>	<ul style="list-style-type: none"> <li>• Roofed</li> <li>• Protected against rain and snow</li> <li>• Shock-free</li> </ul>	Up to 3 years with regular checks of the packaging and moisture indicator (rel. humidity < 50%)
	Open	<ul style="list-style-type: none"> <li>• Under roof and enclosed at constant temperature and atmospheric humidity (5 °C &lt; <math>\vartheta</math> &lt; 50 °C, &lt; 50% relative humidity)</li> <li>• No sudden temperature variations</li> <li>• Controlled ventilation with filter (free from dust and dirt)</li> <li>• No aggressive vapors</li> <li>• No shocks</li> <li>• Protected against insect damage</li> </ul>	2 years or more with regular inspections <ul style="list-style-type: none"> <li>• Check for cleanness and mechanical damage during the inspection</li> <li>• Check corrosion protection</li> </ul>

1) The packaging must be carried out by an experienced company using the packaging materials that have been explicitly specified for the particular application.



2) SEW-EURODRIVE recommends to store the gear units according to the mounting position.

## 8.2 Lubricants

Unless a special arrangement is made, SEW-EURODRIVE supplies the drives with a lubricant fill adapted for the specific gear unit and mounting position. The mounting position (M1 – M6, see chapter "Mounting positions (→ 110)") must be specified in the order. You must adapt the lubricant fill in case of any subsequent changes made to the mounting position, see chapter "Lubricant fill quantities (→ 151)".

### 8.2.1 Bearing greases

The gear unit rolling bearings are given a factory-fill with the greases listed below. SEW-EURODRIVE recommends re-greasing the rolling bearings with a grease filling at the same time as changing the oil.

	Ambient temperature	Manufacturer	Type
Gear unit rolling bearings	-40 °C to +80 °C	Fuchs	Renolit CX-TOM 15 <sup>1)</sup>
	-40 °C to +80 °C	Klüber	Petamo GHY 133 N
	-40 °C to +40 °C	Castrol	Castrol Optileb GR FS 2
	-20 °C to +40 °C	Fuchs	Plantogel 2S

1) Bearing grease based on semi-synthetic base oil.

## INFORMATION



The following grease quantities are required:

- **For fast-running bearings (gear unit input side):** Fill the cavities between the rolling elements one-third full with grease.
- **For slow-running bearings (gear unit output end):** Fill the cavities between the rolling elements two-thirds full with grease.

### 8.2.2 Lubricant table

The lubricant table on the following page shows the permitted lubricants for SEW-EURODRIVE gear units.

#### Key to lubricant table

CLP PG = Polyglycol (W gear units, conforms to USDA-H1)

CLP HC = Synthetic hydrocarbons

E = Ester oil (water hazard class 1 (German regulation – "WKG"))

HCE = Synthetic hydrocarbons + ester oil (USDA - H1 certification)

HLP = Hydraulic oil

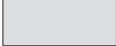
 = Synthetic lubricant (= synthetic roller bearing grease)

1) Helical-worm gear units with PG oil: please consult SEW-EURODRIVE

2) Special lubricant for SPIROPLAN® gear units only

3) Use SEW  $f_B \geq 1.2$

4) Pay attention to critical starting behavior at low temperatures.

5) Low-viscosity grease

6 Ambient temperature

7) Bold

 Lubricant for the food industry (food grade oil)

 Biodegradable oil (lubricant for agriculture, forestry, and fisheries)

Lubricant table

01 751 09 04

	6)	DIN (ISO)	ISO, NLGI	Mobil®	Shell	bp	ELMOR	TEXACO	Castrol	FUCHS	TOTAL
R. K37-187 (HK..) F..	Standard -15	CLP (CC)	VG 220	Mobilgear 600 XP 220	Shell Omala S2 G 220	BP Energol GR-XP 220	Küboroil GEM 1-220 N	Meropa 220	Tribol 1100/220	Renolin CLP 220	Carter EP 220
	+80	CLP PG	VG 220	Mobil Glygoyle 220	Shell Omala S4 WE 220	BP Enerlyn SG-XP 220	Kübersynth GH 6-220	Synlube CLP 220	Optiflex A 220	Renolin Unisyn CLP 220	Carter SY 220
	-20	CLP HC	VG 220	Mobil SHC 630	Shell Omala S4 GX 220		Küboroil GEM 4-220 N	Pinnacle EP 220	Optiflex X 220	Renolin Unisyn CLP 150	Carter SH 220
	-40	CLP HC	VG 150	Mobil SHC 629	Shell Omala S4 GX 150	BP Energol GR-XP 150	Kübersynth GEM 4-150 N	Pinnacle EP 150	Optiflex X 150	Renolin Unisyn CLP 150	Carter SH 150
K..19 - K..49	+25	CLP (CC)	VG 150	Mobilgear 600 XP 150	Shell Omala S2 G 150	BP Energol GR-XP 150	Küboroil GEM 1-150 N	Meropa 150	Tribol 1100/150	Renolin CLP 150	Carter EP 150
	+20	CLP HC	VG 68	Mobil SHC 626	Shell Omala S4 GX 68		Küboroil GEM 1-680 N			Renolin Unisyn CLP 68	
	+0	CLP HC	VG 32	Mobil SHC 624			Kübersynth HYSyn FG-32	Cetus PAO 46	Optiflex HY 32	Renolin Unisyn OL 32	Daenis SH 32
	Standard +60	CLP PG	VG 460				Kübersynth UH1 6-460				
K..49	-20	H1 PG	VG 460				Kübersynth UH1 6-460				
	+60	CLP (CC)	VG 680	Mobilgear 600 XP 680	Shell Omala S2 G 680	BP Energol GR-XP 680	Küboroil GEM 1-680 N	Meropa 680	Tribol 1100/680	Renolin SEW 680	Carter EP 680
	+80	CLP PG	VG 680	Mobil Glygoyle 680	Shell Omala S4 WE 680	BP Enerlyn SG-XP 680	Kübersynth GH 6-680	Synlube CLP 680	Optiflex A 680	Renolin PG 680	
	-20	CLP HC	VG 460	Mobil SHC 634	Shell Omala S4 GX 460		Kübersynth GEM 4-460 N	Pinnacle EP 460	Optiflex Synthetic X 460	Renolin Unisyn CLP 460	Carter SH 460
S..(HS..)	+30	CLP HC	VG 150	Mobil SHC 629	Shell Omala S4 GX 150		Kübersynth GEM 4-150 N	Pinnacle EP 150	Optiflex Synthetic X 150	Renolin Unisyn CLP 150	Carter SH 150
	+10	CLP (CC)	VG 150	Mobilgear 600 XP 150	Shell Omala S2 G 150	BP Energol GR-XP 150	Küboroil GEM 1-150 N	Meropa 150	Optiflex BM 150	Renolin CLP 150	Carter EP 150
	+40	CLP PG	VG 220	Mobil Glygoyle 220	Shell Omala S4 WE 220	BP Enerlyn SG-XP 220	Kübersynth GH 6-220	Synlube CLP 220	Optiflex A 220	Renolin PG 220	Carter SY 220
	-40	CLP HC	VG 68	Mobil SHC 626	Shell Omala S4 GX 68		Küboroil GEM 1-680 N			Renolin Unisyn CLP 68	
R.. K37-187 (HK..) F.. S..(HS..)	0	CLP HC	VG 32	Mobil SHC 624			Küboroil GEM 1-320 N	Cetus PAO 46	Alphasyn T32	Renolin Unisyn OL 32	Daenis SH 32
	-10	CLPHC NSF H1	VG 460				Küboroil 4UH1-460 N		Optiflex GT 460	Cassida Fluid GL 460	
	+30	CLP HC	VG 220	Mobil Synth 75 W90			Küboroil 4UH1-220 N		Optiflex GT 220	Cassida Fluid GL 220	
	0	CLP HC	VG 68				Küboroil 4UH1-68 N		Optiflex HY 68	Cassida Fluid HF 68	Plantogear 460 S
W..(HW..)	+40	CLP HC	VG 460	Mobil SHC 624			Küboroil CA2-460				
	-20	CLP HC	VG 460				Küboroil HT-460-5				
	+10	API GL5	SAE 75W90 (-VG 100)								
	+60	H1 PG	VG 460				Kübersynth UH1 6-460				
PS.F..	+60	CLP PG	VG 220	Mobilgear 600 XP 220			Kübersynth GH 6-220				
	-20	H1 PG	VG 460				Kübersynth UH1 6-460				
	+60	CLP HC	VG 32	Mobil SHC 624							
	Standard +40	CLP (CC)	VG 220								
P.S.C..	+40	DIN 51 818	NLGI 00	Mobilux EP 004							
	+40	DIN 51 818	NLGI 1				Kübersynth UH1 14-151				
	0	CLP HC	VG 32	Mobil SHC 624							
	Standard +60	CLP PG	VG 220				Kübersynth GH 6-220				
BS.F..	-20	H1 PG	VG 460				Kübersynth UH1 6-460				
	+60	CLP PG	VG 460								

54043198373448075

INFORMATION



This lubricant recommendation in no way represents a guarantee as to the quality of the lubricant delivered by each respective supplier. Each lubricant manufacturer is responsible for the quality of their product. Thus the lubricant table is not binding. It may be necessary to contact SEW-EURODRIVE.

21932786/EN – 05/2015

### 8.2.3 Lubricant fill quantities

## INFORMATION



The specified fill quantities are only given as a **guideline**. The precise values vary depending on the number of stages and gear ratio. When filling, it is essential to check the **oil level plug since it indicates the precise oil volume**.

The following tables show guide values for lubricant fill quantities in relation to the mounting position M1 – M6.

### Helical (R) gear units

R..., R..F

Gear unit	Fill quantity in liters					
	M1 <sup>1)</sup>	M2	M3	M4	M5	M6
R07	0.12	0.20				
R17	0.25	0.55	0.35	0.55	0.35	0.40
R27	0.25/0.40	0.70	0.50	0.70	0.50	
R37	0.30/0.95	0.85	0.95	1.05	0.75	0.95
R47	0.70/1.50	1.60	1.50	1.65	1.50	
R57	0.80/1.70	1.90	1.70	2.10	1.70	
R67	1.10/2.30	2.40	2.80	2.90	1.80	2.00
R77	1.20/3.00	3.30	3.60	3.80	2.50	3.40
R87	2.30/6.0	6.4	7.2		6.3	6.5
R97	4.60/9.8	11.7		13.4	11.3	11.7
R107	6.0/13.7	16.3	16.9	19.2	13.2	15.9
R137	10.0/25.0	28.0	29.5	31.5	25.0	
R147	15.4/40.0	46.5	48.0	52.0	39.5	41.0
R167	27.0/70.0	82.0	78.0	88.0	66.0	69.0

1) The larger gear unit of multi-stage gear units must be filled with the larger oil quantity.

RF..., RZ..

Gear unit	Fill quantity in liters					
	M1 <sup>1)</sup>	M2	M3	M4	M5	M6
RF07	0.12	0.20				
RF17	0.25	0.55	0.35	0.55	0.35	0.40
RF27	0.25/0.40	0.70	0.50	0.70	0.50	
RF37	0.35/0.95	0.90	0.95	1.05	0.75	0.95
RF47	0.65/1.50	1.60	1.50	1.65	1.50	
RF57	0.80/1.70	1.80	1.70	2.00	1.70	
RF67	1.20/2.50	2.50	2.70	2.80	1.90	2.10
RF77	1.20/2.60	3.10	3.30	3.60	2.40	3.00
RF87	2.40/6.0	6.4	7.1	7.2	6.3	6.4
RF97	5.1/10.2	11.9	11.2	14.0	11.2	11.8
RF107	6.3/14.9	15.9	17.0	19.2	13.1	15.9
RF137	9.5/25.0	27.0	29.0	32.5	25.0	
RF147	16.4/42.0	47.0	48.0	52.0	42.0	42.0
RF167	26.0/70.0	82.0	78.0	88.0	65.0	71.0

1) The larger gear unit of multi-stage gear units must be filled with the larger oil quantity.

## RX..

Gear unit	Fill quantity in liters					
	M1	M2	M3	M4	M5	M6
RX57	0.60	0.80	1.30		0.90	
RX67	0.80		1.70	1.90	1.10	
RX77	1.10	1.50	2.60	2.70	1.60	
RX87	1.70	2.50	4.80		2.90	
RX97	2.10	3.40	7.4	7.0	4.80	
RX107	3.90	5.6	11.6	11.9	7.7	

## RXF..

Gear unit	Fill quantity in liters					
	M1	M2	M3	M4	M5	M6
RXF57	0.50	0.80	1.10		0.70	
RXF67	0.70	0.80	1.50	1.40	1.00	
RXF77	0.90	1.30	2.40	2.00	1.60	
RXF87	1.60	1.95	4.90	3.95	2.90	
RXF97	2.10	3.70	7.1	6.3	4.80	
RXF107	3.10	5.7	11.2	9.3	7.2	

## Parallel-shaft helical (F) gear units

## F.., FA..B, FH..B, FV..B

Gear units	Fill quantity in liters					
	M1	M2	M3	M4	M5	M6
F..27	0.60	0.80	0.65	0.70	0.60	
F..37	0.95	1.25	0.70	1.25	1.00	1.10
F..47	1.50	1.80	1.10	1.90	1.50	1.70
F..57	2.60	3.50	2.10	3.50	2.80	2.90
F..67	2.70	3.80	1.90	3.80	2.90	3.20
F..77	5.9	7.3	4.30	8.0	6.0	6.3
F..87	10.8	13.0	7.7	13.8	10.8	11.0
F..97	18.5	22.5	12.6	25.2	18.5	20.0
F..107	24.5	32.0	19.5	37.5	27.0	
F..127	40.5	54.5	34.0	61.0	46.3	47.0
F..157	69.0	104.0	63.0	105.0	86.0	78.0

## FF..

Gear units	Fill quantity in liters					
	M1	M2	M3	M4	M5	M6
FF27	0.60	0.80	0.65	0.70	0.60	
FF37	1.00	1.25	0.70	1.30	1.00	
FF47	1.60	1.85	1.10	1.90	1.50	1.70
FF57	2.80	3.50	2.10	3.70	2.90	3.00
FF67	2.70	3.80	1.90	3.80	2.90	3.20
FF77	5.9	7.3	4.30	8.1	6.0	6.3
FF87	10.8	13.2	7.8	14.1	11.0	11.2
FF97	19.0	22.5	12.6	25.6	18.9	20.5
FF107	25.5	32.0	19.5	38.5	27.5	28.0
FF127	41.5	55.5	34.0	63.0	46.3	49.0
FF157	72.0	105.0	64.0	106.0	87.0	79.0



FA.., FH.., FV.., FAF.., FAZ.., FHF.., FZ.., FHZ.., FVF.., FVZ.., FT..

Gear units	Fill quantity in liters					
	M1	M2	M3	M4	M5	M6
F..27	0.60	0.80	0.65	0.70	0.60	
F..37	0.95	1.25	0.70	1.25	1.00	1.10
F..47	1.50	1.80	1.10	1.90	1.50	1.70
F..57	2.70	3.50	2.10	3.40	2.90	3.00
F..67	2.70	3.80	1.90	3.80	2.90	3.20
F..77	5.9	7.3	4.30	8.0	6.0	6.3
F..87	10.8	13.0	7.7	13.8	10.8	11.0
F..97	18.5	22.5	12.6	25.2	18.5	20.0
F..107	24.5	32.0	19.5	37.5	27.0	
F..127	39.0	54.5	34.0	61.0	45.0	46.5
F..157	68.0	103.0	62.0	104.0	85.0	79.5

### Helical-bevel (K) gear units

## INFORMATION



All K..9 gear have a universal mounting position, which means that K..9 gear units of the same design are filled with the same oil quantity independent of the mounting position. An exception to this is the M4 mounting position.

K.., KA..B, KH..B, KV..B

Gear unit	Fill quantity in liters					
	M1	M2	M3	M4	M5	M6
K..19	0.4			0.45	0.4	
K..29	0.7			0.85	0.7	
K..39	0.86	1.65	1.54	2.13	1.53	1.31
K..49	1.64	3.35	2.82	4.18	3.13	2.77
K..37	0.50	1.00		1.25	0.95	
K..47	0.80	1.30	1.50	2.00	1.60	
K..57	1.10	2.20		2.80	2.30	2.10
K..67	1.10	2.40	2.60	3.45	2.60	
K..77	2.20	4.10	4.40	5.8	4.20	4.40
K..87	3.70	8.0	8.7	10.9	8.0	
K..97	7.0	14.0	15.7	20.0	15.7	15.5
K..107	10.0	21.0	25.5	33.5	24.0	
K..127	21.0	41.5	44.0	54.0	40.0	41.0
K..157	31.0	62.0	65.0	90.0	58.0	62.0
K..167	33.0	95.0	105.0	123.0	85.0	84.0
K..187	53.0	152.0	167.0	200	143.0	

KF..

Gear unit	Fill quantity in liters					
	M1	M2	M3	M4	M5	M6
KF19		0.4		0.45		0.4
KF29		0.7		0.85		0.7
KF39	0.86	1.65	1.54	2.13	1.53	1.31
KF49	1.64	3.35	2.82	4.18	3.13	2.77
KF37	0.50	1.10		1.50	1.00	
KF47	0.80	1.30	1.70	2.20	1.60	
KF57	1.20	2.20	2.40	3.15	2.50	2.30
KF67	1.10	2.40	2.80	3.70	2.70	
KF77	2.10	4.10	4.40	5.9	4.50	
KF87	3.70	8.2	9.0	11.9	8.4	
KF97	7.0	14.7	17.3	21.5	15.7	16.5
KF107	10.0	21.8	25.8	35.1	25.2	
KF127	21.0	41.5	46.0	55.0	41.0	
KF157	31.0	66.0	69.0	92.0	62.0	

KA.., KH.., KV.., KAF.., KHF.., KVF.., KZ.., KAZ.., KHZ.., KVZ.., KT..

Gear unit	Fill quantity in liters					
	M1	M2	M3	M4	M5	M6
K..19		0.4		0.45		0.4
K..29		0.7		0.85		0.7
K..39	0.86	1.65	1.54	2.13	1.53	1.31
K..49	1.64	3.35	2.82	4.18	3.13	2.77
K..37	0.50	1.00		1.40	1.00	
K..47	0.80	1.30	1.60	2.15	1.60	
K..57	1.20	2.20	2.40	3.15	2.70	2.40
K..67	1.10	2.40	2.70	3.70	2.60	
K..77	2.10	4.10	4.60	5.9	4.40	
K..87	3.70	8.2	8.8	11.1	8.0	
K..97	7.0	14.7	15.7	20.0	15.7	
K..107	10.0	20.5	24.0	32.4	24.0	
K..127	21.0	41.5	43.0	52.0	40.0	
K..157	31.0	66.0	67.0	87.0	62.0	
K..167	33.0	95.0	105.0	123.0	85.0	84.0
K..187	53.0	152.0	167.0	200	143.0	

## Helical-worm (S) gear units

S..

Gear unit	Fill quantity in liters					
	M1	M2	M3 <sup>1)</sup>	M4	M5	M6
S37	0.25	0.40	0.50	0.55	0.40	
S47	0.35	0.80	0.70/0.90	1.00	0.80	
S57	0.50	1.20	1.00/1.20	1.45	1.30	
S67	1.00	2.00	2.20/3.10	3.10	2.60	2.60
S77	1.90	4.20	3.70/5.4	5.9	4.40	
S87	3.30	8.1	6.9/10.4	11.3	8.4	
S97	6.8	15.0	13.4/18.0	21.8	17.0	

1) The larger gear unit of multi-stage gear units must be filled with the larger oil quantity.

SF..

Gear unit	Fill quantity in liters					
	M1	M2	M3 <sup>1)</sup>	M4	M5	M6
SF37	0.25	0.40	0.50	0.55	0.40	
SF47	0.40	0.90	0.90/1.05	1.05	1.00	
SF57	0.50	1.20	1.00/1.50	1.55	1.40	
SF67	1.00	2.20	2.30/3.00	3.20	2.70	
SF77	1.90	4.10	3.90/5.8	6.5	4.90	
SF87	3.80	8.0	7.1/10.1	12.0	9.1	
SF97	7.4	15.0	13.8/18.8	22.6	18.0	

1) The larger gear unit of multi-stage gear units must be filled with the larger oil quantity.

SA.., SH.., SAF.., SHZ.., SAZ.., SHF.., ST..

Gear unit	Fill quantity in liters					
	M1	M2	M3 <sup>1)</sup>	M4	M5	M6
S..37	0.25	0.40	0.50		0.40	
S..47	0.40	0.80	0.70/0.90	1.00	0.80	
S..57	0.50	1.10	1.00/1.50	1.50	1.20	
S..67	1.00	2.00	1.80/2.60	2.90	2.50	
S..77	1.80	3.90	3.60/5.0	5.8	4.50	
S..87	3.80	7.4	6.0/8.7	10.8	8.0	
S..97	7.0	14.0	11.4/16.0	20.5	15.7	

1) The larger gear unit of multi-stage gear units must be filled with the larger oil quantity.

## SPIROPLAN® (W) gear units



### INFORMATION

SPIROPLAN® gear units W..10 to W..30 have a universal mounting position, which means that gear units of the same design are filled with the same amount of oil independent of the mounting position.

The oil fill quantity of SPIROPLAN® gear units W..37 and W..47 in mounting position M4 is different from that of the other mounting positions.

W.., WA..B, WH..B

Gear units	Fill quantity in liters					
	M1	M2	M3	M4	M5	M6
W..10	0.16					
W..20	0.24					
W..30	0.40					
W..37	0.50		0.70		0.50	
W..47	0.90		1.40		0.90	

WF..

Gear units	Fill quantity in liters					
	M1	M2	M3	M4	M5	M6
WF10	0.16					
WF20	0.24					
WF30	0.40					
WF37	0.50		0.70		0.50	
WF47	0.90		1.55		0.90	

WA.., WAF..,WH.., WT.., WHF..

Gear units	Fill quantity in liters					
	M1	M2	M3	M4	M5	M6
W..10	0.16					
W..20	0.24					
W..30	0.40					
W..37	0.50		0.70		0.50	
W..47	0.80		1.40		0.80	

## 9 Malfunctions



### ▲ WARNING

Risk of crushing if the drive starts up unintentionally.

Severe or fatal injuries.

- De-energize the motor before you start working on the unit.
- Secure the motor against unintended power-up.



### ▲ CAUTION

Risk of burns due to hot gear unit and hot gear unit oil.

Severe injuries.

- Let the gear unit cool down before you start working on it.
- Carefully remove the oil level plug and the oil drain plug.

### NOTICE

Damage to gear unit due to improper operation.

Damage to the gear unit/gearmotor.

- Repair works at SEW-EURODRIVE gear units may only be performed by qualified personnel. In the context of this documentation, qualified personnel are persons who are familiar with the "Technical regulations on operating safety" (TRBS).
- Drive and motor may only be disconnected by qualified personnel.
- Contact SEW-EURODRIVE.

## 9.1 Gear units

Fault	Possible cause	Measure
Unusual, regular running noise	<ul style="list-style-type: none"> <li>Meshing/grinding noise: Bearing damage</li> <li>Knocking noise: Irregularity in the gearing</li> <li>Deformation of the housing upon tightening</li> <li>Noise generated by insufficient stiffness of the gear unit foundation</li> </ul>	<ul style="list-style-type: none"> <li>Check oil consistency, change bearings</li> <li>Consult SEW-EURODRIVE</li> <li>Check the gear unit mounting for possible deformation and correct if necessary</li> <li>Reinforce the gear unit foundation</li> </ul>
Unusual, irregular running noises	<ul style="list-style-type: none"> <li>Foreign objects in the oil</li> </ul>	<ul style="list-style-type: none"> <li>Checking the oil consistency</li> <li>Stop the drive, contact SEW-EURODRIVE</li> </ul>
Oil leaking from inspection cover	<ul style="list-style-type: none"> <li>Seal of the inspection cover leaking</li> </ul>	<ul style="list-style-type: none"> <li>Tighten the screws of the inspection cover and observe the gear unit. Contact SEW-EURODRIVE if oil is still leaking.</li> </ul>
	<ul style="list-style-type: none"> <li>Seal defective</li> </ul>	<ul style="list-style-type: none"> <li>Contact SEW-EURODRIVE.</li> </ul>
Small amounts of oil leak from the oil seal during run-in phase.	<ul style="list-style-type: none"> <li>Function-related pseudo-leakage</li> </ul>	<ul style="list-style-type: none"> <li>There is no fault. Remove with soft, lint-free cloth and keep monitoring it.</li> </ul>
Film of moisture around the dust lip of the oil seal	<ul style="list-style-type: none"> <li>Function-related pseudo-leakage</li> </ul>	<ul style="list-style-type: none"> <li>There is no fault. Remove with soft, lint-free cloth and keep monitoring it.</li> </ul>
Oil leaking from the oil seal.	<ul style="list-style-type: none"> <li>Oil seal leaking/defective</li> </ul>	<ul style="list-style-type: none"> <li>Check sealing system. It may be necessary to contact SEW-EURODRIVE.</li> </ul>
Oil leaking from motor (e.g. terminal box or fan)	<ul style="list-style-type: none"> <li>Too much oil</li> </ul>	<ul style="list-style-type: none"> <li>Check oil level, correct if necessary</li> </ul>
	<ul style="list-style-type: none"> <li>Gear unit not ventilated</li> </ul>	<ul style="list-style-type: none"> <li>Vent gear unit</li> </ul>
	<ul style="list-style-type: none"> <li>Oil seal leaking/defective</li> </ul>	<ul style="list-style-type: none"> <li>Check sealing system. It may be necessary to contact SEW-EURODRIVE.</li> </ul>
Oil leaking from flange	<ul style="list-style-type: none"> <li>Flange gasket leaking/defective</li> </ul>	<ul style="list-style-type: none"> <li>Check sealing system. It may be necessary to contact SEW-EURODRIVE.</li> </ul>
	<ul style="list-style-type: none"> <li>Too much oil</li> </ul>	<ul style="list-style-type: none"> <li>Check oil level, correct if necessary</li> </ul>
	<ul style="list-style-type: none"> <li>Gear unit not ventilated</li> </ul>	<ul style="list-style-type: none"> <li>Vent gear unit</li> </ul>
Oil leaking from breather valve.	<ul style="list-style-type: none"> <li>Too much oil.</li> </ul>	<ul style="list-style-type: none"> <li>Check oil quantity, correct if necessary</li> </ul>
	<ul style="list-style-type: none"> <li>Function-related oil mist</li> </ul>	<ul style="list-style-type: none"> <li>There is no fault.</li> </ul>
	<ul style="list-style-type: none"> <li>Drive not installed in proper mounting position.</li> </ul>	<ul style="list-style-type: none"> <li>Install breather valve correctly and adjust the oil level.</li> </ul>
	<ul style="list-style-type: none"> <li>Frequent cold starts (oil foaming) and/or high oil level.</li> </ul>	<ul style="list-style-type: none"> <li>Install oil expansion tank.</li> </ul>
Output shaft does not turn although the motor is running or the input shaft is rotated.	<ul style="list-style-type: none"> <li>Shaft-hub connection in the gear unit interrupted.</li> </ul>	<ul style="list-style-type: none"> <li>Send in the gear unit/gearmotor for repair</li> </ul>

## 9.2 Adapters AM/AQ./AL/EWH

Fault	Possible cause	Measure
Unusual, regular running noise	<ul style="list-style-type: none"> <li>Meshing/grinding noise: Bearing damage</li> </ul>	<ul style="list-style-type: none"> <li>Contact SEW-EURODRIVE.</li> </ul>
Oil leaking.	<ul style="list-style-type: none"> <li>Seal defective</li> </ul>	<ul style="list-style-type: none"> <li>Contact SEW-EURODRIVE.</li> </ul>
Output shaft does not turn although the motor is running or the input shaft is rotated.	<ul style="list-style-type: none"> <li>Shaft-hub connection in the gear unit interrupted.</li> </ul>	<ul style="list-style-type: none"> <li>Send in the gear unit/gearmotor for repair.</li> </ul>
Change in running noise and/or vibrations	<ul style="list-style-type: none"> <li>Ring gear wear, short-term torque transmission through metal contact</li> </ul>	<ul style="list-style-type: none"> <li>Change the ring gear.</li> </ul>
	<ul style="list-style-type: none"> <li>Screws to secure hub axially are loose</li> </ul>	<ul style="list-style-type: none"> <li>Tighten the screws</li> </ul>
Premature wear in girth gear	<ul style="list-style-type: none"> <li>Contact with aggressive fluids/oils; ozone influence; excessive ambient temperatures, etc. that can change the physical properties of the ring gear.</li> </ul>	<ul style="list-style-type: none"> <li>Contact SEW-EURODRIVE.</li> </ul>
	<ul style="list-style-type: none"> <li>Impermissibly high ambient/contact temperature for the girth gear; maximum permitted temperature: -20 °C to +80 °C.</li> </ul>	<ul style="list-style-type: none"> <li>Contact SEW-EURODRIVE.</li> </ul>
	<ul style="list-style-type: none"> <li>Overload</li> </ul>	<ul style="list-style-type: none"> <li>Contact SEW-EURODRIVE.</li> </ul>

## 9.3 AD input shaft assembly

Fault	Possible cause	Measure
Unusual, regular running noise.	<ul style="list-style-type: none"> <li>Meshing/grinding noise: Bearing damage.</li> </ul>	<ul style="list-style-type: none"> <li>Contact SEW-EURODRIVE.</li> </ul>
Oil is leaking.	<ul style="list-style-type: none"> <li>Seal defective.</li> </ul>	<ul style="list-style-type: none"> <li>Contact SEW-EURODRIVE.</li> </ul>
Output shaft does not turn although the input shaft is rotated.	<ul style="list-style-type: none"> <li>Shaft-hub connection in gear unit or cover interrupted.</li> </ul>	<ul style="list-style-type: none"> <li>Send the gear unit to SEW-EURODRIVE for repair.</li> </ul>

#### 9.4 Customer service

If you require customer service, include the following information:

- Nameplate data (complete)
- Nature and extent of the problem
- Time the failure occurred and any accompanying circumstances
- Presumed cause
- A digital picture of the failure, if possible.

#### 9.5 Waste disposal

Dispose gear units in accordance with the material structure and the regulations in force:

- As steel scrap
  - Housing parts
  - Gears
  - Shafts
  - Rolling bearing
- Parts of the worm gears are made of non-ferrous metals. Dispose of the worm gears appropriately.
- Collect used oil and dispose of it according to the regulations in force.



## 10 Address list

<b>Algeria</b>			
Sales	Algiers	REDUCOM Sarl 16, rue des Frères Zaghroune Bellevue 16200 El Harrach Alger	Tel. +213 21 8214-91 Fax +213 21 8222-84 <a href="http://www.reducom-dz.com">http://www.reducom-dz.com</a> <a href="mailto:info@reducom-dz.com">info@reducom-dz.com</a>
<b>Argentina</b>			
Assembly Sales	Buenos Aires	SEW EURODRIVE ARGENTINA S.A. Ruta Panamericana Km 37.5, Lote 35 (B1619IEA) Centro Industrial Garín Prov. de Buenos Aires	Tel. +54 3327 4572-84 Fax +54 3327 4572-21 <a href="http://www.sew-eurodrive.com.ar">http://www.sew-eurodrive.com.ar</a> <a href="mailto:sewar@sew-eurodrive.com.ar">sewar@sew-eurodrive.com.ar</a>
<b>Australia</b>			
Assembly Sales Service	Melbourne	SEW-EURODRIVE PTY. LTD. 27 Beverage Drive Tullamarine, Victoria 3043	Tel. +61 3 9933-1000 Fax +61 3 9933-1003 <a href="http://www.sew-eurodrive.com.au">http://www.sew-eurodrive.com.au</a> <a href="mailto:enquires@sew-eurodrive.com.au">enquires@sew-eurodrive.com.au</a>
	Sydney	SEW-EURODRIVE PTY. LTD. 9, Sleigh Place, Wetherill Park New South Wales, 2164	Tel. +61 2 9725-9900 Fax +61 2 9725-9905 <a href="mailto:enquires@sew-eurodrive.com.au">enquires@sew-eurodrive.com.au</a>
<b>Austria</b>			
Assembly Sales Service	Vienna	SEW-EURODRIVE Ges.m.b.H. Richard-Strauss-Strasse 24 A-1230 Wien	Tel. +43 1 617 55 00-0 Fax +43 1 617 55 00-30 <a href="http://www.sew-eurodrive.at">http://www.sew-eurodrive.at</a> <a href="mailto:sew@sew-eurodrive.at">sew@sew-eurodrive.at</a>
<b>Bangladesh</b>			
Sales	Bangladesh	SEW-EURODRIVE INDIA PRIVATE LIMITED 345 DIT Road East Rampura Dhaka-1219, Bangladesh	Tel. +88 01729 097309 <a href="mailto:salesdhaka@seweurodrivebangladesh.com">salesdhaka@seweurodrivebangladesh.com</a>
<b>Belarus</b>			
Sales	Minsk	Foreign Enterprise Industrial Components RybalkoStr. 26 BY-220033 Minsk	Tel. +375 17 298 47 56 / 298 47 58 Fax +375 17 298 47 54 <a href="http://www.sew.by">http://www.sew.by</a> <a href="mailto:sales@sew.by">sales@sew.by</a>
<b>Belgium</b>			
Assembly Sales Service	Brussels	SEW-EURODRIVE n.v./s.a. Researchpark Haasrode 1060 Evenementenlaan 7 BE-3001 Leuven	Tel. +32 16 386-311 Fax +32 16 386-336 <a href="http://www.sew-eurodrive.be">http://www.sew-eurodrive.be</a> <a href="mailto:info@sew-eurodrive.be">info@sew-eurodrive.be</a>
Service Competence Center	Industrial Gears	SEW-EURODRIVE n.v./s.a. Rue de Parc Industriel, 31 BE-6900 Marche-en-Famenne	Tel. +32 84 219-878 Fax +32 84 219-879 <a href="http://www.sew-eurodrive.be">http://www.sew-eurodrive.be</a> <a href="mailto:service-wallonie@sew-eurodrive.be">service-wallonie@sew-eurodrive.be</a>
<b>Brazil</b>			
Production Sales Service	São Paulo	SEW-EURODRIVE Brasil Ltda. Estrada Municipal José Rubim, 205 – Rodovia Santos Dumont Km 49 Indaiatuba – 13347-510 – SP	Tel. +55 19 3835-8000 <a href="mailto:sew@sew.com.br">sew@sew.com.br</a>
Assembly Sales Service	Rio Claro	SEW-EURODRIVE Brasil Ltda. Rodovia Washington Luiz, Km 172 Condomínio Industrial Conpark Caixa Postal: 327 13501-600 – Rio Claro / SP	Tel. +55 19 3522-3100 Fax +55 19 3524-6653 <a href="mailto:montadora.rc@sew.com.br">montadora.rc@sew.com.br</a>
	Joinville	SEW-EURODRIVE Brasil Ltda. Rua Dona Francisca, 12.346 – Pirabeiraba 89239-270 – Joinville / SC	Tel. +55 47 3027-6886 Fax +55 47 3027-6888 <a href="mailto:filial.sc@sew.com.br">filial.sc@sew.com.br</a>
<b>Bulgaria</b>			
Sales	Sofia	BEVER-DRIVE GmbH Bogdanovetz Str.1 BG-1606 Sofia	Tel. +359 2 9151160 Fax +359 2 9151166 <a href="mailto:bever@bever.bg">bever@bever.bg</a>

## Cameroon

is supported by Germany.

## Canada

Assembly Sales Service	Toronto	SEW-EURODRIVE CO. OF CANADA LTD. 210 Walker Drive Bramalea, ON L6T 3W1	Tel. +1 905 791-1553 Fax +1 905 791-2999 <a href="http://www.sew-eurodrive.ca">http://www.sew-eurodrive.ca</a> l.watson@sew-eurodrive.ca
	Vancouver	SEW-EURODRIVE CO. OF CANADA LTD. Tilbury Industrial Park 7188 Honeyman Street Delta, BC V4G 1G1	Tel. +1 604 946-5535 Fax +1 604 946-2513 b.wake@sew-eurodrive.ca
	Montreal	SEW-EURODRIVE CO. OF CANADA LTD. 2555 Rue Leger Lasalle, PQ H8N 2V9	Tel. +1 514 367-1124 Fax +1 514 367-3677 a.peluso@sew-eurodrive.ca

## Chile

Assembly Sales Service	Santiago de Chile	SEW-EURODRIVE CHILE LTDA Las Encinas 1295 Parque Industrial Valle Grande LAMPA RCH-Santiago de Chile P.O. Box Casilla 23 Correo Quilicura - Santiago - Chile	Tel. +56 2 2757 7000 Fax +56 2 2757 7001 <a href="http://www.sew-eurodrive.cl">http://www.sew-eurodrive.cl</a> ventas@sew-eurodrive.cl
------------------------------	-------------------	--	---

## China

Production Assembly Sales Service	Tianjin	SEW-EURODRIVE (Tianjin) Co., Ltd. No. 78, 13th Avenue, TEDA Tianjin 300457	Tel. +86 22 25322612 Fax +86 22 25323273 <a href="http://www.sew-eurodrive.cn">http://www.sew-eurodrive.cn</a> info@sew-eurodrive.cn
	Suzhou	SEW-EURODRIVE (Suzhou) Co., Ltd. 333, Suhong Middle Road Suzhou Industrial Park Jiangsu Province, 215021	Tel. +86 512 62581781 Fax +86 512 62581783 suzhou@sew-eurodrive.cn
	Guangzhou	SEW-EURODRIVE (Guangzhou) Co., Ltd. No. 9, JunDa Road East Section of GETDD Guangzhou 510530	Tel. +86 20 82267890 Fax +86 20 82267922 guangzhou@sew-eurodrive.cn
Assembly Sales Service	Shenyang	SEW-EURODRIVE (Shenyang) Co., Ltd. 10A-2, 6th Road Shenyang Economic Technological Development Area Shenyang, 110141	Tel. +86 24 25382538 Fax +86 24 25382580 shenyang@sew-eurodrive.cn
	Taiyuan	SEW-EURODRIVE (Taiyuan) Co., Ltd. No.3, HuaZhang Street, TaiYuan Economic & Technical Development Zone ShanXi, 030032	Tel. +86-351-7117520 Fax +86-351-7117522 taiyuan@sew-eurodrive.cn
	Wuhan	SEW-EURODRIVE (Wuhan) Co., Ltd. 10A-2, 6th Road No. 59, the 4th Quanli Road, WEDA 430056 Wuhan	Tel. +86 27 84478388 Fax +86 27 84478389 wuhan@sew-eurodrive.cn
Sales Service	Xi'An	SEW-EURODRIVE (Xi'An) Co., Ltd. No. 12 Jinye 2nd Road Xi'An High-Technology Industrial Development Zone Xi'An 710065	Tel. +86 29 68686262 Fax +86 29 68686311 xian@sew-eurodrive.cn
	Hong Kong	SEW-EURODRIVE LTD. Unit No. 801-806, 8th Floor Hong Leong Industrial Complex No. 4, Wang Kwong Road Kowloon, Hong Kong	Tel. +852 36902200 Fax +852 36902211 contact@sew-eurodrive.hk

## Colombia

Assembly Sales Service	Bogota	SEW-EURODRIVE COLOMBIA LTDA. Calle 22 No. 132-60 Bodega 6, Manzana B Santafé de Bogotá	Tel. +57 1 54750-50 Fax +57 1 54750-44 <a href="http://www.sew-eurodrive.com.co">http://www.sew-eurodrive.com.co</a> sew@sew-eurodrive.com.co
------------------------------	--------	---	--

<b>Croatia</b>			
Sales Service	Zagreb	KOMPEKS d. o. o. Zeleni dol 10 HR 10 000 Zagreb	Tel. +385 1 4613-158 Fax +385 1 4613-158 kompeks@inet.hr
<b>Czech Republic</b>			
Assembly Sales Service	Hostivice	SEW-EURODRIVE CZ s.r.o. Floriánova 2459 253 01 Hostivice	Tel. +420 255 709 601 Fax +420 235 350 613 <a href="http://www.sew-eurodrive.cz">http://www.sew-eurodrive.cz</a> sew@sew-eurodrive.cz
	Drive Service Hotline / 24 Hour Service	+420 800 739 739 (800 SEW SEW)	Service Tel. +420 255 709 632 Fax +420 235 358 218 servis@sew-eurodrive.cz
<b>Denmark</b>			
Assembly Sales Service	Copenhagen	SEW-EURODRIVEA/S Geminivej 28-30 DK-2670 Greve	Tel. +45 43 95 8500 Fax +45 43 9585-09 <a href="http://www.sew-eurodrive.dk">http://www.sew-eurodrive.dk</a> sew@sew-eurodrive.dk
<b>Egypt</b>			
Sales Service	Cairo	Copam Egypt for Engineering & Agencies 33 El Hegaz ST Heliopolis, Cairo	Tel. +20 222566299 Fax +20 2 22594-757 <a href="http://www.copam-egypt.com">http://www.copam-egypt.com</a> copam@copam-egypt.com
<b>Estonia</b>			
Sales	Tallin	ALAS-KUUL AS Reti tee 4 EE-75301 Peetri küla, Rae vald, Harjumaa	Tel. +372 6593230 Fax +372 6593231 <a href="http://www.alas-kuul.ee">http://www.alas-kuul.ee</a> veiko.soots@alas-kuul.ee
<b>Finland</b>			
Assembly Sales Service	Hollola	SEW-EURODRIVE OY Vesimäentie 4 FIN-15860 Hollola 2	Tel. +358 201 589-300 Fax +358 3 780-6211 <a href="http://www.sew-eurodrive.fi">http://www.sew-eurodrive.fi</a> sew@sew.fi
Service	Hollola	SEW-EURODRIVE OY Keskikankaantie 21 FIN-15860 Hollola	Tel. +358 201 589-300 Fax +358 3 780-6211 <a href="http://www.sew-eurodrive.fi">http://www.sew-eurodrive.fi</a> sew@sew.fi
Production Assembly	Karkkila	SEW Industrial Gears Oy Santasalonkatu 6, PL 8 FI-03620 Karkkila, 03601 Karkkila	Tel. +358 201 589-300 Fax +358 201 589-310 <a href="http://www.sew-eurodrive.fi">http://www.sew-eurodrive.fi</a> sew@sew.fi
<b>France</b>			
Production Sales Service	Hagenau	SEW-USOCOME 48-54 route de Soufflenheim B. P. 20185 F-67506 Hagenau Cedex	Tel. +33 3 88 73 67 00 Fax +33 3 88 73 66 00 <a href="http://www.usocome.com">http://www.usocome.com</a> sew@usocome.com
Production	Forbach	SEW-USOCOME Zone industrielle Technopôle Forbach Sud B. P. 30269 F-57604 Forbach Cedex	Tel. +33 3 87 29 38 00
	Brumath	SEW-USOCOME 1 rue de Bruxelles F-67670 Mommenheim	Tel. +33 3 88 37 48 48
Assembly Sales Service	Bordeaux	SEW-USOCOME Parc d'activités de Magellan 62 avenue de Magellan – B. P. 182 F-33607 Pessac Cedex	Tel. +33 5 57 26 39 00 Fax +33 5 57 26 39 09
	Lyon	SEW-USOCOME Parc d'affaires Roosevelt Rue Jacques Tati F-69120 Vaulx en Velin	Tel. +33 4 72 15 37 00 Fax +33 4 72 15 37 15

## France

Nantes	SEW-USOCOME Parc d'activités de la forêt 4 rue des Fontenelles F-44140 Le Bignon	Tel. +33 2 40 78 42 00 Fax +33 2 40 78 42 20
Paris	SEW-USOCOME Zone industrielle 2 rue Denis Papin F-77390 Verneuil l'Étang	Tel. +33 1 64 42 40 80 Fax +33 1 64 42 40 88

## Gabon

is supported by Germany.

## Germany

Headquarters Production Sales	Bruchsal	SEW-EURODRIVE GmbH & Co KG Ernst-Blickle-Straße 42 D-76646 Bruchsal P.O. Box Postfach 3023 – D-76642 Bruchsal	Tel. +49 7251 75-0 Fax +49 7251 75-1970 <a href="http://www.sew-eurodrive.de">http://www.sew-eurodrive.de</a> <a href="mailto:sew@sew-eurodrive.de">sew@sew-eurodrive.de</a>
Production / Industrial Gears	Bruchsal	SEW-EURODRIVE GmbH & Co KG Christian-Pähr-Str. 10 D-76646 Bruchsal	Tel. +49 7251 75-0 Fax +49 7251 75-2970
Production	Graben	SEW-EURODRIVE GmbH & Co KG Ernst-Blickle-Straße 1 D-76676 Graben-Neudorf P.O. Box Postfach 1220 – D-76671 Graben-Neudorf	Tel. +49 7251 75-0 Fax +49 7251-2970
	Östringen	SEW-EURODRIVE GmbH & Co KG, Werk Östringen Franz-Gurk-Straße 2 D-76684 Östringen	Tel. +49 7253 9254-0 Fax +49 7253 9254-90 <a href="mailto:oestringen@sew-eurodrive.de">oestringen@sew-eurodrive.de</a>
Service Competence Center	Mechanics / Mechatronics	SEW-EURODRIVE GmbH & Co KG Ernst-Blickle-Straße 1 D-76676 Graben-Neudorf	Tel. +49 7251 75-1710 Fax +49 7251 75-1711 <a href="mailto:scc-mechanik@sew-eurodrive.de">scc-mechanik@sew-eurodrive.de</a>
	Electronics	SEW-EURODRIVE GmbH & Co KG Ernst-Blickle-Straße 42 D-76646 Bruchsal	Tel. +49 7251 75-1780 Fax +49 7251 75-1769 <a href="mailto:scc-elektronik@sew-eurodrive.de">scc-elektronik@sew-eurodrive.de</a>
Drive Technology Center	North	SEW-EURODRIVE GmbH & Co KG Alte Ricklinger Straße 40-42 D-30823 Garbsen (Hannover)	Tel. +49 5137 8798-30 Fax +49 5137 8798-55 <a href="mailto:dtc-nord@sew-eurodrive.de">dtc-nord@sew-eurodrive.de</a>
	East	SEW-EURODRIVE GmbH & Co KG Dänkritzter Weg 1 D-08393 Meerane (Zwickau)	Tel. +49 3764 7606-0 Fax +49 3764 7606-30 <a href="mailto:dtc-ost@sew-eurodrive.de">dtc-ost@sew-eurodrive.de</a>
	South	SEW-EURODRIVE GmbH & Co KG Domagkstraße 5 D-85551 Kirchheim (München)	Tel. +49 89 909552-10 Fax +49 89 909552-50 <a href="mailto:dtc-sued@sew-eurodrive.de">dtc-sued@sew-eurodrive.de</a>
	West	SEW-EURODRIVE GmbH & Co KG Siemensstraße 1 D-40764 Langenfeld (Düsseldorf)	Tel. +49 2173 8507-30 Fax +49 2173 8507-55 <a href="mailto:dtc-west@sew-eurodrive.de">dtc-west@sew-eurodrive.de</a>
Drive Center	Berlin	SEW-EURODRIVE GmbH & Co KG Alexander-Meißner-Straße 44 D-12526 Berlin	Tel. +49 306331131-30 Fax +49 306331131-36 <a href="mailto:dc-berlin@sew-eurodrive.de">dc-berlin@sew-eurodrive.de</a>
	Ludwigshafen	SEW-EURODRIVE GmbH & Co KG c/o BASF SE Gebäude W130 Raum 101 D-67056 Ludwigshafen	Tel. +49 7251 75 3759 Fax +49 7251 75 503759 <a href="mailto:dc-ludwigshafen@sew-eurodrive.de">dc-ludwigshafen@sew-eurodrive.de</a>
	Saarland	SEW-EURODRIVE GmbH & Co KG Gottlieb-Daimler-Straße 4 D-66773 Schwalbach Saar – Hülzweiler	Tel. +49 6831 48946 10 Fax +49 6831 48946 13 <a href="mailto:dc-saarland@sew-eurodrive.de">dc-saarland@sew-eurodrive.de</a>
	Ulm	SEW-EURODRIVE GmbH & Co KG Dieselstraße 18 D-89160 Dornstadt	Tel. +49 7348 9885-0 Fax +49 7348 9885-90 <a href="mailto:dc-ulm@sew-eurodrive.de">dc-ulm@sew-eurodrive.de</a>
	Würzburg	SEW-EURODRIVE GmbH & Co KG Nürnbergerstraße 118 D-97076 Würzburg-Lengfeld	Tel. +49 931 27886-60 Fax +49 931 27886-66 <a href="mailto:dc-wuerzburg@sew-eurodrive.de">dc-wuerzburg@sew-eurodrive.de</a>
Drive Service Hotline / 24 Hour Service			+49 800 SEWHELP +49 800 7394357

<b>Great Britain</b>			
Assembly Sales Service	Normanton	SEW-EURODRIVE Ltd. DeVilliers Way Trident Park Normanton West Yorkshire WF6 1GX	Tel. +44 1924 893-855 Fax +44 1924 893-702 <a href="http://www.sew-eurodrive.co.uk">http://www.sew-eurodrive.co.uk</a> <a href="mailto:info@sew-eurodrive.co.uk">info@sew-eurodrive.co.uk</a>
		Drive Service Hotline / 24 Hour Service	Tel. 01924 896911
<b>Greece</b>			
Sales	Athens	Christ. Boznos & Son S.A. 12, K. Mavromichali Street P.O. Box 80136 GR-18545 Piraeus	Tel. +30 2 1042 251-34 Fax +30 2 1042 251-59 <a href="http://www.boznos.gr">http://www.boznos.gr</a> <a href="mailto:info@boznos.gr">info@boznos.gr</a>
<b>Hungary</b>			
Sales Service	Budapest	SEW-EURODRIVE Kft. Csillaghegyi út 13. H-1037 Budapest	Tel. +36 1 437 06-58 Fax +36 1 437 06-50 <a href="http://www.sew-eurodrive.hu">http://www.sew-eurodrive.hu</a> <a href="mailto:office@sew-eurodrive.hu">office@sew-eurodrive.hu</a>
<b>Iceland</b>			
Sales	Reykjavik	Varma & Vélaverk ehf. Knarrarvogi 4 IS-104 Reykjavik	Tel. +354 585 1070 Fax +354 585)1071 <a href="http://www.varmaverk.is">http://www.varmaverk.is</a> <a href="mailto:vov@vov.is">vov@vov.is</a>
<b>India</b>			
Registered Office Assembly Sales Service	Vadodara	SEW-EURODRIVE India Private Limited Plot No. 4, GIDC POR Ramangamdi • Vadodara - 391 243 Gujarat	Tel. +91 265 3045200 Fax +91 265 3045300 <a href="http://www.seweurodriveindia.com">http://www.seweurodriveindia.com</a> <a href="mailto:salesvadodara@seweurodriveindia.com">salesvadodara@seweurodriveindia.com</a>
Assembly Sales Service	Chennai	SEW-EURODRIVE India Private Limited Plot No. K3/1, Sipcot Industrial Park Phase II Mambakkam Village Sriperumbudur - 602105 Kancheepuram Dist, Tamil Nadu	Tel. +91 44 37188888 Fax +91 44 37188811 <a href="mailto:saleschennai@seweurodriveindia.com">saleschennai@seweurodriveindia.com</a>
	Pune	SEW-EURODRIVE India Private Limited Plant: Plot No. D236/1, Chakan Industrial Area Phase- II, Warale, Tal- Khed, Pune-410501, Maharashtra	Tel. +91 21 35301400 <a href="mailto:salespune@seweurodriveindia.com">salespune@seweurodriveindia.com</a>
<b>Indonesia</b>			
Sales	Jakarta	PT. Cahaya Sukses Abadi Komplek Rukan Puri Mutiara Blok A no 99, Sunter Jakarta 14350	Tel. +62 21 65310599 Fax +62 21 65310600 <a href="mailto:csajkt@cbn.net.id">csajkt@cbn.net.id</a>
	Jakarta	PT. Agrindo Putra Lestari JL.Pantai Indah Selatan, Komplek Sentra Industri Terpadu, Pantai indah Kapuk Tahap III, Blok E No. 27 Jakarta 14470	Tel. +62 21 2921-8899 Fax +62 21 2921-8988 <a href="mailto:aplindo@indosat.net.id">aplindo@indosat.net.id</a> <a href="http://www.aplindo.com">http://www.aplindo.com</a>
	Medan	PT. Serumpun Indah Lestari Jl.Pulau Solor no. 8, Kawasan Industri Medan II Medan 20252	Tel. +62 61 687 1221 Fax +62 61 6871429 / +62 61 6871458 / +62 61 30008041 <a href="mailto:sil@serumpunindah.com">sil@serumpunindah.com</a> <a href="mailto:serumpunindah@yahoo.com">serumpunindah@yahoo.com</a> <a href="http://www.serumpunindah.com">http://www.serumpunindah.com</a>
	Surabaya	PT. TRIAGRI JAYA ABADI Jl. Sukosemolo No. 63, Galaxi Bumi Permai G6 No. 11 Surabaya 60111	Tel. +62 31 5990128 Fax +62 31 5962666 <a href="mailto:sales@triagri.co.id">sales@triagri.co.id</a> <a href="http://www.triagri.co.id">http://www.triagri.co.id</a>
	Surabaya	CV. Multi Mas Jl. Raden Saleh 43A Kav. 18 Surabaya 60174	Tel. +62 31 5458589 Fax +62 31 5317220 <a href="mailto:sianhwa@sby.centrin.net.id">sianhwa@sby.centrin.net.id</a> <a href="http://www.cvmultimas.com">http://www.cvmultimas.com</a>

## Ireland

Sales Service	Dublin	Alperton Engineering Ltd. 48 Moyle Road Dublin Industrial Estate Glasnevin, Dublin 11	Tel. +353 1 830-6277 Fax +353 1 830-6458 <a href="http://www.alperton.ie">http://www.alperton.ie</a> info@alperton.ie
------------------	--------	--	--

## Israel

Sales	Tel Aviv	Liraz Handasa Ltd. Ahofer Str 34B / 228 58858 Holon	Tel. +972 3 5599511 Fax +972 3 5599512 <a href="http://www.liraz-handasa.co.il">http://www.liraz-handasa.co.il</a> office@liraz-handasa.co.il
-------	----------	---	--

## Italy

Assembly Sales Service	Solaro	SEW-EURODRIVE di R. Blicke & Co.s.a.s. Via Bernini, 14 I-20020 Solaro (Milano)	Tel. +39 02 96 9801 Fax +39 02 96 79 97 81 <a href="http://www.sew-eurodrive.it">http://www.sew-eurodrive.it</a> sewit@sew-eurodrive.it
------------------------------	--------	--	--

## Ivory Coast

Sales	Abidjan	SEW-EURODRIVE SARL Ivory Coast Rue des Pêcheurs, Zone 3 26 BP 916 Abidjan 26	Tel. +225 21 21 81 05 Fax +225 21 25 30 47 info@sew-eurodrive.ci <a href="http://www.sew-eurodrive.ci">http://www.sew-eurodrive.ci</a>
-------	---------	---	---

## Japan

Assembly Sales Service	Iwata	SEW-EURODRIVE JAPAN CO., LTD 250-1, Shimoman-no, Iwata Shizuoka 438-0818	Tel. +81 538 373811 Fax +81 538 373814 <a href="http://www.sew-eurodrive.co.jp">http://www.sew-eurodrive.co.jp</a> sewjapan@sew-eurodrive.co.jp hamamatsu@sew-eurodrive.co.jp
------------------------------	-------	---	---

## Kazakhstan

Sales	Almaty	SEW-EURODRIVE LLP 291-291A, Tole bi street 050031, Almaty	Tel. +7 (727) 350 5156 Fax +7 (727) 350 5156 <a href="http://www.sew-eurodrive.kz">http://www.sew-eurodrive.kz</a> sew@sew-eurodrive.kz
	Tashkent	SEW-EURODRIVE LLP Representative office in Uzbekistan 96A, Sharaf Rashidov street, Tashkent, 100084	Tel. +998 71 2359411 Fax +998 71 2359412 <a href="http://www.sew-eurodrive.uz">http://www.sew-eurodrive.uz</a> sew@sew-eurodrive.uz
	Ulaanbaatar	SEW-EURODRIVE LLP Representative office in Mongolia Suite 407, Tushig Centre Seoul street 23, Sukhbaatar district, Ulaanbaatar 14250	Tel. +976-77109997 Fax +976-77109997 <a href="http://www.sew-eurodrive.mn">http://www.sew-eurodrive.mn</a> sew@sew-eurodrive.mn

## Kenya

is supported by Tanzania.

## Latvia

Sales	Riga	SIA Alas-Kuul Kattakalna 11C LV-1073 Riga	Tel. +371 6 7139253 Fax +371 6 7139386 <a href="http://www.alas-kuul.lv">http://www.alas-kuul.lv</a> info@alas-kuul.com
-------	------	---	--

## Lebanon

Sales Lebanon	Beirut	Gabriel Acar & Fils sarl B. P. 80484 Bourj Hammoud, Beirut	Tel. +961 1 510 532 Fax +961 1 494 971 ssacar@inco.com.lb
Sales / Jordan / Ku- wait / Saudi Arabia / Syria	Beirut	Middle East Drives S.A.L. (offshore) Sin El Fil. B. P. 55-378 Beirut	Tel. +961 1 494 786 Fax +961 1 494 971 <a href="http://www.medrives.com">http://www.medrives.com</a> info@medrives.com

<b>Lithuania</b>			
Sales	Alytus	UAB Irseva Statybininku 106C LT-63431 Alytus	Tel. +370 315 79204 Fax +370 315 56175 <a href="http://www.sew-eurodrive.lt">http://www.sew-eurodrive.lt</a> irmantas@irseva.lt
<b>Luxembourg</b>			
Assembly Sales Service	Brussels	SEW-EURODRIVE n.v./s.a. Researchpark Haasrode 1060 Evenementenlaan 7 BE-3001 Leuven	Tel. +32 16 386-311 Fax +32 16 386-336 <a href="http://www.sew-eurodrive.lu">http://www.sew-eurodrive.lu</a> info@sew-eurodrive.be
<b>Macedonia</b>			
Sales	Skopje	Boznos DOOEL Dime Anicin 2A/7A 1000 Skopje	Tel. +389 23256553 Fax +389 23256554 <a href="http://www.boznos.mk">http://www.boznos.mk</a>
<b>Madagascar</b>			
Sales	Antananarivo	Ocean Trade BP21bis. Andraharo Antananarivo 101 Madagascar	Tel. +261 20 2330303 Fax +261 20 2330330 oceantrabp@moov.mg
<b>Malaysia</b>			
Assembly Sales Service	Johor	SEW-EURODRIVE SDN BHD No. 95, Jalan Seroja 39, Taman Johor Jaya 81000 Johor Bahru, Johor West Malaysia	Tel. +60 7 3549409 Fax +60 7 3541404 sales@sew-eurodrive.com.my
<b>Mexiko</b>			
Assembly Sales Service	Quéretaro	SEW-EURODRIVE MEXICO SA DE CV SEM-981118-M93 Tequisquiapan No. 102 Parque Industrial Quéretaro C.P. 76220 Quéretaro, México	Tel. +52 442 1030-300 Fax +52 442 1030-301 <a href="http://www.sew-eurodrive.com.mx">http://www.sew-eurodrive.com.mx</a> scmexico@seweurodrive.com.mx
<b>Mongolia</b>			
Technical Office	Ulaanbaatar	SEW-EURODRIVE LLP Representative office in Mongolia Suite 407, Tushig Centre Seoul street 23, Sukhbaatar district, Ulaanbaatar 14250	Tel. +976-77109997 Fax +976-77109997 <a href="http://www.sew-eurodrive.mn">http://www.sew-eurodrive.mn</a> sew@sew-eurodrive.mn
<b>Morocco</b>			
Sales Service	Mohammedia	SEW-EURODRIVE SARL 2 bis, Rue Al Jahid 28810 Mohammedia	Tel. +212 523 32 27 80/81 Fax +212 523 32 27 89 <a href="http://www.sew-eurodrive.ma">http://www.sew-eurodrive.ma</a> sew@sew-eurodrive.ma
<b>Namibia</b>			
Sales	Swakopmund	DB Mining & Industrial Services Einstein Street Strauss Industrial Park Unit1 Swakopmund	Tel. +264 64 462 738 Fax +264 64 462 734 anton@dbminingnam.com
<b>Netherlands</b>			
Assembly Sales Service	Rotterdam	SEW-EURODRIVE B.V. Industrieweg 175 NL-3044 AS Rotterdam Postbus 10085 NL-3004 AB Rotterdam	Tel. +31 10 4463-700 Fax +31 10 4155-552 Service: 0800-SEWHELP <a href="http://www.sew-eurodrive.nl">http://www.sew-eurodrive.nl</a> info@sew-eurodrive.nl
<b>New Zealand</b>			
Assembly Sales Service	Auckland	SEW-EURODRIVE NEW ZEALAND LTD. P.O. Box 58-428 82 Greenmount drive East Tamaki Auckland	Tel. +64 9 2745627 Fax +64 9 2740165 <a href="http://www.sew-eurodrive.co.nz">http://www.sew-eurodrive.co.nz</a> sales@sew-eurodrive.co.nz

<b>New Zealand</b>			
	Christchurch	SEW-EURODRIVE NEW ZEALAND LTD. 30 Lodestar Avenue, Wigram Christchurch	Tel. +64 3 384-6251 Fax +64 3 384-6455 sales@sew-eurodrive.co.nz
<b>Nigeria</b>			
Sales	Lagos	EISNL Engineering Solutions and Drives Ltd Plot 9, Block A, Ikeja Industrial Estate ( Ogba Scheme) Adeniyi Jones St. End Off ACME Road, Ogba, Ikeja, Lagos	Tel. +234 1 217 4332 http://www.eisnl.com team.sew@eisnl.com
<b>Norway</b>			
Assembly Sales Service	Moss	SEW-EURODRIVE A/S Solgaard skog 71 N-1599 Moss	Tel. +47 69 24 10 20 Fax +47 69 24 10 40 http://www.sew-eurodrive.no sew@sew-eurodrive.no
<b>Pakistan</b>			
Sales	Karachi	Industrial Power Drives Al-Fatah Chamber A/3, 1st Floor Central Commercial Area, Sultan Ahmed Shah Road, Block 7/8, Karachi	Tel. +92 21 452 9369 Fax +92-21-454 7365 seweurodrive@cyber.net.pk
<b>Paraguay</b>			
Sales	Fernando de la Mora	SEW-EURODRIVE PARAGUAY S.R.L De la Victoria 112, Esquina nueva Asunción Departamento Central Fernando de la Mora, Barrio Bernardino	Tel. +595 991 519695 Fax +595 21 3285539 sewpy@sew-eurodrive.com.py
<b>Peru</b>			
Assembly Sales Service	Lima	SEW EURODRIVE DEL PERU S.A.C. Los Calderos, 120-124 Urbanizacion Industrial Vulcano, ATE, Lima	Tel. +51 1 3495280 Fax +51 1 3493002 http://www.sew-eurodrive.com.pe sewperu@sew-eurodrive.com.pe
<b>Philippines</b>			
Sales	Makati	P.T. Cerna Corporation 4137 Ponte St., Brgy. Sta. Cruz Makati City 1205	Tel. +63 2 519 6214 Fax +63 2 890 2802 mech_drive_sys@ptcerna.com http://www.ptcerna.com
<b>Poland</b>			
Assembly Sales Service	Łódź	SEW-EURODRIVE Polska Sp.z.o.o. ul. Techniczna 5 PL-92-518 Łódź	Tel. +48 42 293 00 00 Fax +48 42 293 00 49 http://www.sew-eurodrive.pl sew@sew-eurodrive.pl
	Service	Tel. +48 42 293 0030 Fax +48 42 293 0043	24 Hour Service Tel. +48 602 739 739 (+48 602 SEW SEW) serwis@sew-eurodrive.pl
<b>Portugal</b>			
Assembly Sales Service	Coimbra	SEW-EURODRIVE, LDA. Av. da Fonte Nova, n.º 86 P-3050-379 Mealhada	Tel. +351 231 20 9670 Fax +351 231 20 3685 http://www.sew-eurodrive.pt infosew@sew-eurodrive.pt
<b>Romania</b>			
Sales Service	Bucharest	Sialco Trading SRL str. Brazilia nr. 36 011783 Bucuresti	Tel. +40 21 230-1328 Fax +40 21 230-7170 sialco@sialco.ro
<b>Russia</b>			
Assembly Sales Service	St. Petersburg	ZAO SEW-EURODRIVE P.O. Box 36 RUS-195220 St. Petersburg	Tel. +7 812 3332522 / +7 812 5357142 Fax +7 812 3332523 http://www.sew-eurodrive.ru sew@sew-eurodrive.ru



**Sambia**

is supported by South Africa.

**Senegal**

Sales	Dakar	SENEMECA Mécanique Générale Km 8, Route de Rufisque B.P. 3251, Dakar	Tel. +221 338 494 770 Fax +221 338 494 771 <a href="http://www.senemeca.com">http://www.senemeca.com</a> senemeca@senemeca.sn
-------	-------	---	--

**Serbia**

Sales	Belgrade	DIPAR d.o.o. Ustanička 128a PC Košum, IV floor SRB-11000 Beograd	Tel. +381 11 347 3244 / +381 11 288 0393 Fax +381 11 347 1337 office@dipar.rs
-------	----------	---	--

**Singapore**

Assembly Sales Service	Singapore	SEW-EURODRIVE PTE. LTD. No 9, Tuas Drive 2 Jurong Industrial Estate Singapore 638644	Tel. +65 68621701 Fax +65 68612827 <a href="http://www.sew-eurodrive.com.sg">http://www.sew-eurodrive.com.sg</a> sewsingapore@sew-eurodrive.com
------------------------------	-----------	---	--

**Slovakia**

Sales	Bratislava	SEW-Eurodrive SK s.r.o. Rybničná 40 SK-831 06 Bratislava	Tel. +421 2 33595 202, 217, 201 Fax +421 2 33595 200 <a href="http://www.sew-eurodrive.sk">http://www.sew-eurodrive.sk</a> sew@sew-eurodrive.sk
	Košice	SEW-Eurodrive SK s.r.o. Slovenská ulica 26 SK-040 01 Košice	Tel. +421 55 671 2245 Fax +421 55 671 2254 Mobile +421 907 671 976 sew@sew-eurodrive.sk

**Slovenia**

Sales Service	Celje	Pakman - Pogonska Tehnika d.o.o. Ul. XIV. divizije 14 SLO - 3000 Celje	Tel. +386 3 490 83-20 Fax +386 3 490 83-21 pakman@siol.net
------------------	-------	--	--

**South Africa**

Assembly Sales Service	Johannesburg	SEW-EURODRIVE (PROPRIETARY) LIMITED Eurodrive House Cnr. Adcock Ingram and Aerodrome Roads Aeroton Ext. 2 Johannesburg 2013 P.O.Box 90004 Bertsham 2013	Tel. +27 11 248-7000 Fax +27 11 248-7289 <a href="http://www.sew.co.za">http://www.sew.co.za</a> info@sew.co.za
	Cape Town	SEW-EURODRIVE (PROPRIETARY) LIMITED Rainbow Park Cnr. Racecourse & Omuramba Road Montague Gardens Cape Town P.O.Box 36556 Chempet 7442	Tel. +27 21 552-9820 Fax +27 21 552-9830 Telex 576 062 bgriffiths@sew.co.za
	Durban	SEW-EURODRIVE (PROPRIETARY) LIMITED 48 Prospecton Road Isipingo Durban P.O. Box 10433, Ashwood 3605	Tel. +27 31 902 3815 Fax +27 31 902 3826 cdejager@sew.co.za
	Nelspruit	SEW-EURODRIVE (PROPRIETARY) LIMITED 7 Christie Crescent Vintonia P.O.Box 1942 Nelspruit 1200	Tel. +27 13 752-8007 Fax +27 13 752-8008 robermeyer@sew.co.za

**South Korea**

Assembly Sales Service	Ansan	SEW-EURODRIVE KOREA CO., LTD. 7, Dangjaengi-ro, Danwon-gu, Ansan-si, Gyeonggi-do, Zip 425-839	Tel. +82 31 492-8051 Fax +82 31 492-8056 <a href="http://www.sew-eurodrive.kr">http://www.sew-eurodrive.kr</a> master.korea@sew-eurodrive.com
------------------------------	-------	--	--

South Korea			
	Busan	SEW-EURODRIVE KOREA CO., LTD. 28, Noksansandan 262-ro 50beon-gil, Gangseo-gu, Busan, Zip 618-820	Tel. +82 51 832-0204 Fax +82 51 832-0230
Spain			
Assembly Sales Service	Bilbao	SEW-EURODRIVE ESPAÑA, S.L. Parque Tecnológico, Edificio, 302 E-48170 Zamudio (Vizcaya)	Tel. +34 94 43184-70 Fax +34 94 43184-71 <a href="http://www.sew-eurodrive.es">http://www.sew-eurodrive.es</a> <a href="mailto:sew.spain@sew-eurodrive.es">sew.spain@sew-eurodrive.es</a>
Sri Lanka			
Sales	Colombo	SM International (Pte) Ltd 254, Galle Raod Colombo 4, Sri Lanka	Tel. +94 1 2584887 Fax +94 1 2582981
Swaziland			
Sales	Manzini	C G Trading Co. (Pty) Ltd PO Box 2960 Manzini M200	Tel. +268 2 518 6343 Fax +268 2 518 5033 <a href="mailto:engineering@cgtrading.co.sz">engineering@cgtrading.co.sz</a>
Sweden			
Assembly Sales Service	Jönköping	SEW-EURODRIVE AB Gnejsvägen 6-8 S-55 303 Jönköping Box 3100 S-55 003 Jönköping	Tel. +46 36 34 42 00 Fax +46 36 34 42 80 <a href="http://www.sew-eurodrive.se">http://www.sew-eurodrive.se</a> <a href="mailto:jonkoping@sew.se">jonkoping@sew.se</a>
Switzerland			
Assembly Sales Service	Basel	Alfred Imhof A.G. Jurastrasse 10 CH-4142 Münchenstein bei Basel	Tel. +41 61 417 1717 Fax +41 61 417 1700 <a href="http://www.imhof-sew.ch">http://www.imhof-sew.ch</a> <a href="mailto:info@imhof-sew.ch">info@imhof-sew.ch</a>
Taiwan			
Sales	Taipei	Ting Shou Trading Co., Ltd. 6F-3, No. 267, Sec. 2 Tung Huw S. Road Taipei	Tel. +886 2 27383535 Fax +886 2 27368268 Telex 27 245 <a href="mailto:sewtwn@ms63.hinet.net">sewtwn@ms63.hinet.net</a> <a href="http://www.tingshou.com.tw">http://www.tingshou.com.tw</a>
	Nan Tou	Ting Shou Trading Co., Ltd. No. 55 Kung Yeh N. Road Industrial District Nan Tou 540	Tel. +886 49 255353 Fax +886 49 257878 <a href="mailto:sewtwn@ms63.hinet.net">sewtwn@ms63.hinet.net</a> <a href="http://www.tingshou.com.tw">http://www.tingshou.com.tw</a>
Tanzania			
Sales	Daressalam	SEW-EURODRIVE PTY LIMITED TANZANIA Plot 52, Regent Estate PO Box 106274 Dar Es Salaam	Tel. +255 0 22 277 5780 Fax +255 0 22 277 5788 <a href="http://www.sew-eurodrive.co.tz">http://www.sew-eurodrive.co.tz</a> <a href="mailto:central.mailbox@sew.co.tz">central.mailbox@sew.co.tz</a>
Thailand			
Assembly Sales Service	Chonburi	SEW-EURODRIVE (Thailand) Ltd. 700/456, Moo.7, Donhuaroh Muang Chonburi 20000	Tel. +66 38 454281 Fax +66 38 454288 <a href="mailto:sewthailand@sew-eurodrive.com">sewthailand@sew-eurodrive.com</a>
Tunisia			
Sales	Tunis	T. M.S. Technic Marketing Service Zone Industrielle Mghira 2 Lot No. 39 2082 Fouchana	Tel. +216 79 40 88 77 Fax +216 79 40 88 66 <a href="http://www.tms.com.tn">http://www.tms.com.tn</a> <a href="mailto:tms@tms.com.tn">tms@tms.com.tn</a>
Turkey			
Assembly Sales Service	Kocaeli-Gebze	SEW-EURODRIVE Hareket Sistemleri San. Ve TIC. Ltd. Sti Gebze Organize Sanayi Böl. 400 Sok No. 401 41480 Gebze Kocaeli	Tel. +90 262 9991000 04 Fax +90 262 9991009 <a href="http://www.sew-eurodrive.com.tr">http://www.sew-eurodrive.com.tr</a> <a href="mailto:sew@sew-eurodrive.com.tr">sew@sew-eurodrive.com.tr</a>

**Ukraine**

Assembly Sales Service	Dnipropetrovsk	ООО «СЕВ-Евродрайв» ул.Рабочая, 23-В, офис 409 49008 Днепропетровск	Tel. +380 56 370 3211 Fax +380 56 372 2078 <a href="http://www.sew-eurodrive.ua">http://www.sew-eurodrive.ua</a> <a href="mailto:sew@sew-eurodrive.ua">sew@sew-eurodrive.ua</a>
------------------------------	----------------	---	--

**United Arab Emirates**

Sales Service	Sharjah	Copam Middle East (FZC) Sharjah Airport International Free Zone P.O. Box 120709 Sharjah	Tel. +971 6 5578-488 Fax +971 6 5578-499 <a href="mailto:copam_me@eim.ae">copam_me@eim.ae</a>
------------------	---------	--	---

**Uruguay**

Assembly Sales	Montevideo	SEW-EURODRIVE Uruguay, S. A. Jose Serrato 3569 Esqina Corumbe CP 12000 Montevideo	Tel. +598 2 21181-89 Fax +598 2 21181-90 <a href="mailto:sewuy@sew-eurodrive.com.uy">sewuy@sew-eurodrive.com.uy</a>
-------------------	------------	---	---

**USA**

Production Assembly Sales Service	Southeast Region	SEW-EURODRIVE INC. 1295 Old Spartanburg Highway P.O. Box 518 Lyman, S.C. 29365	Tel. +1 864 439-7537 Fax Sales +1 864 439-7830 Fax Production +1 864 439-9948 Fax Assembly +1 864 439-0566 Fax Confidential/HR +1 864 949-5557 <a href="http://www.seweurodrive.com">http://www.seweurodrive.com</a> <a href="mailto:cslyman@seweurodrive.com">cslyman@seweurodrive.com</a>
Assembly Sales Service	Northeast Region	SEW-EURODRIVE INC. Pureland Ind. Complex 2107 High Hill Road, P.O. Box 481 Bridgeport, New Jersey 08014	Tel. +1 856 467-2277 Fax +1 856 845-3179 <a href="mailto:csbridgeport@seweurodrive.com">csbridgeport@seweurodrive.com</a>
	Midwest Region	SEW-EURODRIVE INC. 2001 West Main Street Troy, Ohio 45373	Tel. +1 937 335-0036 Fax +1 937 332-0038 <a href="mailto:cstroy@seweurodrive.com">cstroy@seweurodrive.com</a>
	Southwest Region	SEW-EURODRIVE INC. 3950 Platinum Way Dallas, Texas 75237	Tel. +1 214 330-4824 Fax +1 214 330-4724 <a href="mailto:csdallas@seweurodrive.com">csdallas@seweurodrive.com</a>
	Western Region	SEW-EURODRIVE INC. 30599 San Antonio St. Hayward, CA 94544	Tel. +1 510 487-3560 Fax +1 510 487-6433 <a href="mailto:cshayward@seweurodrive.com">cshayward@seweurodrive.com</a>

Additional addresses for service in USA provided on request!

**Uzbekistan**

Technical Office	Tashkent	SEW-EURODRIVE LLP Representative office in Uzbekistan 96A, Sharaf Rashidov street, Tashkent, 100084	Tel. +998 71 2359411 Fax +998 71 2359412 <a href="http://www.sew-eurodrive.uz">http://www.sew-eurodrive.uz</a> <a href="mailto:sew@sew-eurodrive.uz">sew@sew-eurodrive.uz</a>
------------------	----------	--	--

**Venezuela**

Assembly Sales Service	Valencia	SEW-EURODRIVE Venezuela S.A. Av. Norte Sur No. 3, Galpon 84-319 Zona Industrial Municipal Norte Valencia, Estado Carabobo	Tel. +58 241 832-9804 Fax +58 241 838-6275 <a href="http://www.sew-eurodrive.com.ve">http://www.sew-eurodrive.com.ve</a> <a href="mailto:ventas@sew-eurodrive.com.ve">ventas@sew-eurodrive.com.ve</a> <a href="mailto:sewfinanzas@cantv.net">sewfinanzas@cantv.net</a>
------------------------------	----------	--	--

**Vietnam**

Sales	Ho Chi Minh City	Nam Trung Co., Ltd Huế - South Vietnam / Construction Materials 250 Binh Duong Avenue, Thu Dau Mot Town, Binh Duong Province HCM office: 91 Tran Minh Quyen Street District 10, Ho Chi Minh City	Tel. +84 8 8301026 Fax +84 8 8392223 <a href="mailto:khanh-nguyen@namtrung.com.vn">khanh-nguyen@namtrung.com.vn</a> <a href="http://www.namtrung.com.vn">http://www.namtrung.com.vn</a>
	Hanoi	MICO LTD Quảng Trị - North Vietnam / All sectors except Construction Materials 8th Floor, Ocean Park Building, 01 Dao Duy Anh St, Ha Noi, Viet Nam	Tel. +84 4 39386666 Fax +84 4 3938 6888 <a href="mailto:nam_ph@micogroup.com.vn">nam_ph@micogroup.com.vn</a> <a href="http://www.micogroup.com.vn">http://www.micogroup.com.vn</a>

## Index

**A**

AD Input shaft assembly .....	70
Adapter EWH .....	68
Adjustment in mounting position .....	25
AM adapter.....	61
AM IEC adapter.....	61
AM NEMA adapter .....	61
Ambient conditions.....	86
Amount of oil .....	151
AQ adapter.....	65
Permitted loads .....	66
Setting standards and tightening torques .....	66
AQ adapter coupling .....	65
AR.. slip clutch .....	74
AT.. start-up coupling.....	74

**B**

Backstop .....	86
Bearing greases .....	148
Breather valve .....	25

**C**

Change in mounting position.....	25
Changing the mounting position.....	148
Checking the oil level .....	83, 95
At the breather plug .....	102
At the breather plug .....	107
At the cover plate .....	98
At the oil level plug.....	96
At the oil level plug.....	105, 106, 108
Copyright notice .....	7
Coupling of AM adapter .....	61
Coupling, rigid flange coupling .....	78
Cover AD.....	70
Customer service .....	160

**D**

Designated use .....	9
Diagnostic unit	
DUO .....	76
DUV .....	75
DUO, diagnostic unit .....	76
DUV, diagnostic unit.....	75

**E**

Efficiency.....	85
Elastomers .....	86
Embedded safety notes .....	6
EWH adapter.....	68
Exclusion of liability .....	7
Extended storage .....	146

**F**

Failure	
Running noise .....	158, 159
Failures .....	157
Features .....	74
Flatness defect.....	25
Fluid couplings .....	74
Fluorocarbon rubber.....	86
Föttinger principle.....	74

**G**

Gaskets .....	0
Gear unit heating.....	77
Gear unit mounting.....	27
Gear unit painting.....	30
Gear unit structure .....	11
Helical gear units .....	11
Helical-bevel gear units K..7 .....	15
Helical-bevel gear units K..9 .....	13, 14
Helical-worm gear units .....	16
Parallel-shaft helical gear units .....	12
SPIROPLAN® gear units W..10 – W..30 .....	17
SPIROPLAN® gear units W..37 – W..47 .....	18
Gear unit venting.....	28
Gear unit with solid shaft.....	31
General safety notes .....	8
Grease filling .....	148

**H**

Hazard symbols	
Meaning .....	6
Heater .....	77
Helical gear units.....	11
Helical gearmotors	
Mounting positions .....	113
Helical-bevel gear units.....	13, 14

Helical-bevel gear units K..7 .....	15	Checking the oil level .....	95
Helical-bevel gearmotors		Gear unit .....	95
Mounting positions .....	121	Oil change .....	95
Helical-worm gear units .....	16	Malfunctions .....	157
Helical-worm gearmotors		AD Input shaft assembly .....	159
Mounting positions .....	134	Adapters AM/AQ. /AL/EWH .....	159
<b>I</b>		Gear unit .....	158
Input and output elements		Mechanical installation .....	22
High overhung loads .....	32	Mounting position	
Mounting .....	31	M0 .....	111
Using a mounting device .....	31	MX .....	111
Inspection .....	88	Mounting position sheets .....	110
Inspection intervals		Mounting positions .....	110
Gear unit .....	92	Designation .....	110
Inspection work		For SPIROPLAN® gear units .....	112
AD Input shaft assembly .....	94	Helical gearmotors .....	113
AL/AM/AQ./EWH adapter .....	93	Helical-bevel gearmotors .....	121
Checking the oil .....	95	Helical-worm gearmotors .....	134
Checking the oil level .....	95	Icons .....	112
Gear unit .....	95	Key .....	112
Oil change .....	95	Parallel-shaft helical gearmotors .....	118
Installation		SPIROPLAN® gearmotors .....	140
Couplings .....	32	MX mounting position .....	111
Input and output elements .....	31	<b>N</b>	
Mechanical .....	22	Nameplate .....	19
Installation of the gear unit .....	24	Notes	
Installation tolerances .....	23	Designation in the documentation .....	5
Installing the gear unit .....	24	Meaning of the hazard symbols .....	6
<b>L</b>		<b>O</b>	
Labyrinth seal .....	79	Oil change .....	95
Leakage .....	0	Oil check .....	95
Lubricant fill quantities .....	151	Oil drain valve .....	81
Lubricant table .....	149, 150	Oil expansion tank .....	81
Lubricants .....	148	Oil seals .....	22
<b>M</b>		Oil sight glass .....	83
M0 universal mounting position .....	111	Optional equipment .....	74
Maintenance .....	88	Options .....	74
Maintenance intervals		<b>P</b>	
Gear unit .....	92	Painting the gear unit .....	30, 109
Maintenance works		Parallel-shaft helical gear units .....	12
AD Input shaft assembly .....	94	Parallel-shaft helical gearmotors	
AL/AM/AQ./EWH adapter .....	93	Mounting positions .....	118
Checking the oil .....	95	Performance data .....	19

Product names ..... 7  
 Pseudo-leakage ..... 0

**R**

Relubrication ..... 79  
 Repair ..... 160  
 Resources ..... 22  
 Rights to claim under limited warranty ..... 6  
 Rigid flange coupling ..... 78  
 Run-in period ..... 85

**S**

Safety notes  
     Designated use ..... 9  
     Designation in the documentation ..... 5  
     General ..... 8  
     Meaning of the hazard symbols ..... 6  
     Preliminary information ..... 8  
     Structure of embedded ..... 6  
     Structure of the section-related ..... 5  
     Transport ..... 9  
 Screw quality ..... 25  
 Section-related safety notes ..... 5  
 Service ..... 160  
 Shaft-mounted gear units ..... 33  
     Keyway ..... 38  
     Shrink disk ..... 44  
     Splined hollow shaft ..... 38  
     TorqLOC® ..... 47  
 Signal words in the safety notes ..... 5  
 Solid shaft ..... 31  
 SPIROPLAN® gear units  
     Mounting positions ..... 112  
 SPIROPLAN® gear units W..10 – W..30 ..... 17  
 SPIROPLAN® gear units W..37 – W..47 ..... 18  
 SPIROPLAN® gearmotors  
     Mounting positions ..... 140  
 Startup ..... 83  
 Start-up coupling, AT ..... 74  
 Storage conditions ..... 146  
 Structure  
     Helical gear units ..... 11  
     Helical-bevel gear units K..7 ..... 15  
     Helical-bevel gear units K..9 ..... 13, 14  
     Helical-worm gear units ..... 16  
     Parallel-shaft helical gear units ..... 12

SPIROPLAN® gear units W..10 – W..30 ..... 17  
 SPIROPLAN® gear units W..37 – W..47 ..... 18

**T**

Technical data ..... 146  
 Tightening torques ..... 26  
 Tools ..... 22  
 TorqLOC® ..... 47  
 Torque arms ..... 33  
 Torque arms for shaft-mounted gear units ..... 33  
     Helical-bevel gear units K..37 – K..157 ..... 35  
     Helical-worm gear units ..... 36  
     Parallel-shaft helical gear units ..... 33  
     SPIROPLAN® W gear units ..... 37  
 Trademarks ..... 7  
 Transport ..... 9  
 Type designation ..... 19, 21

**U**

Universal mounting position M0 ..... 111  
 Using a mounting device ..... 31

**V**

Ventilation ..... 28  
 Venting ..... 28

**W**

Waste disposal ..... 160

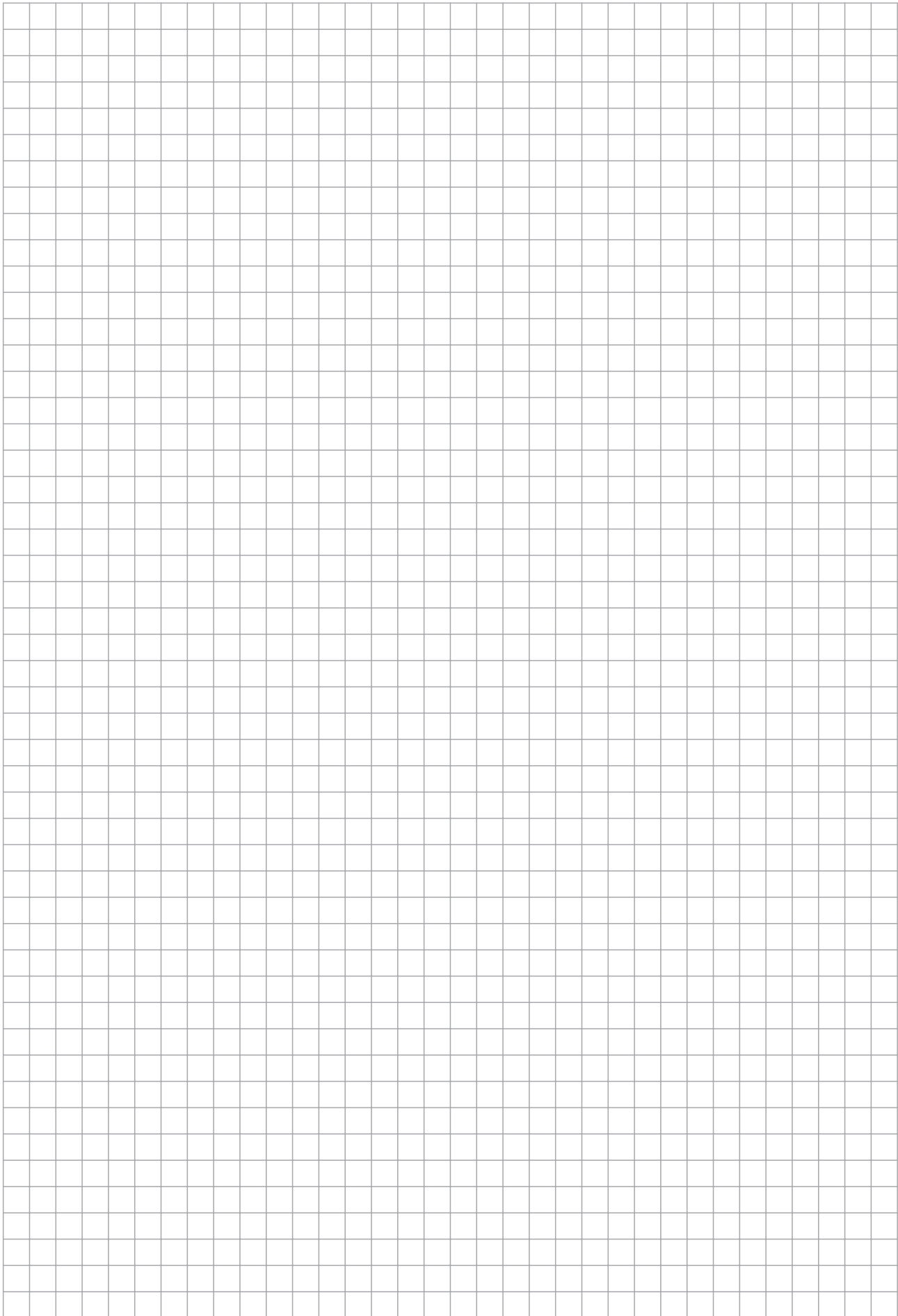

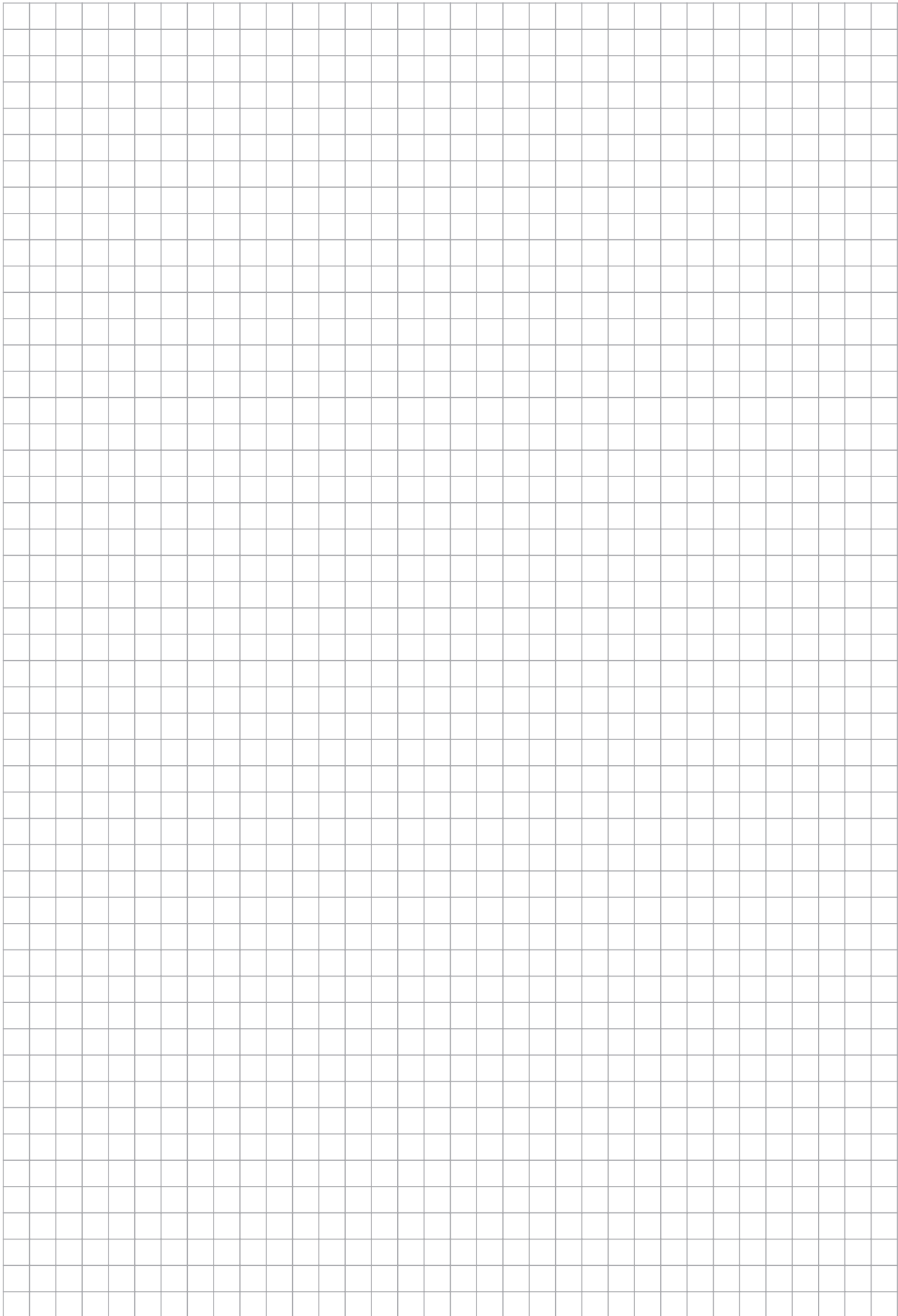



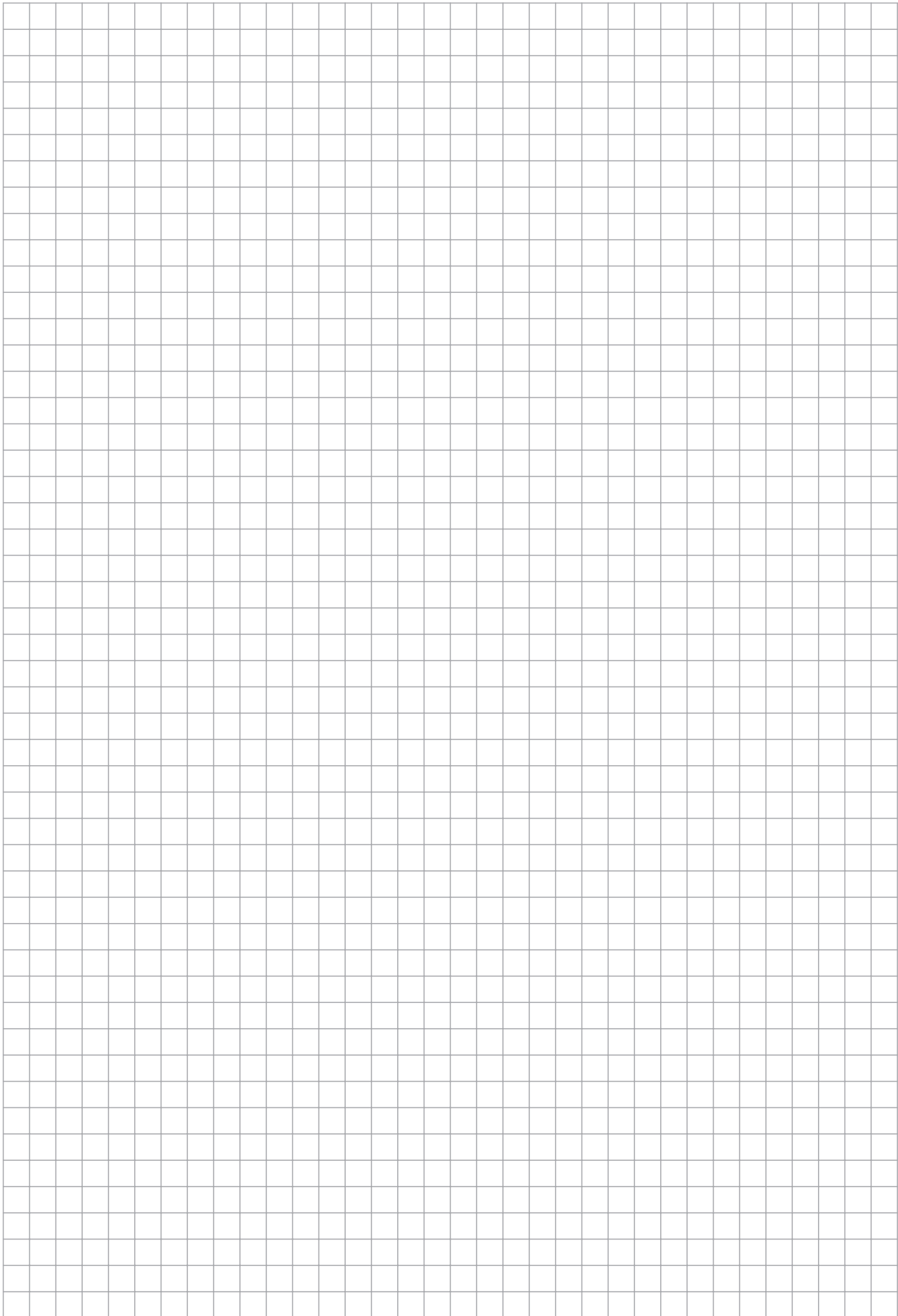

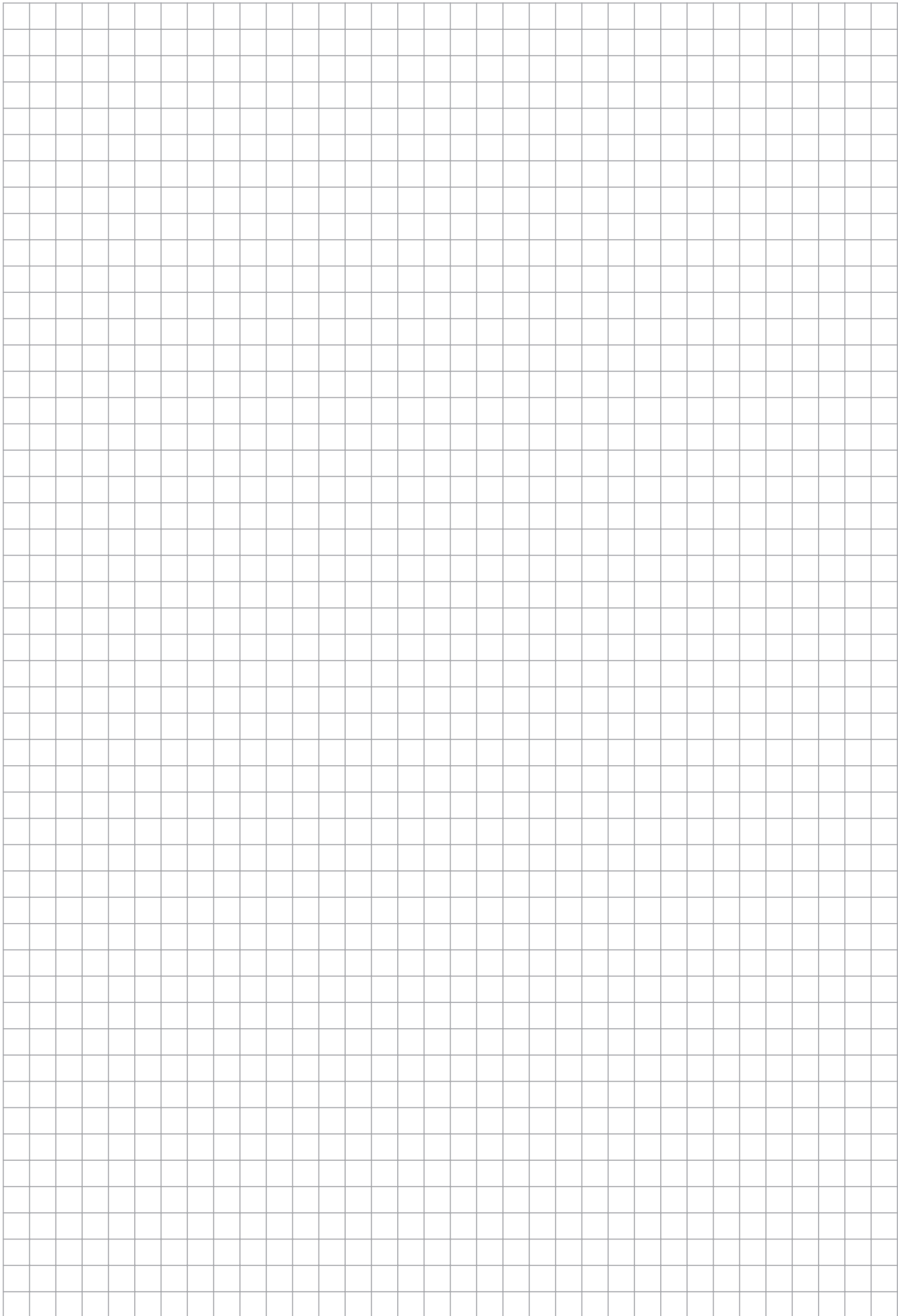

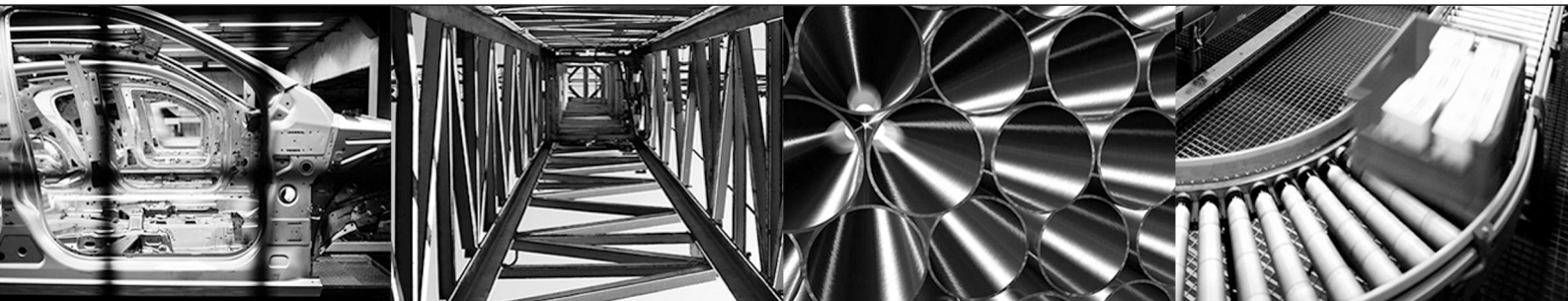

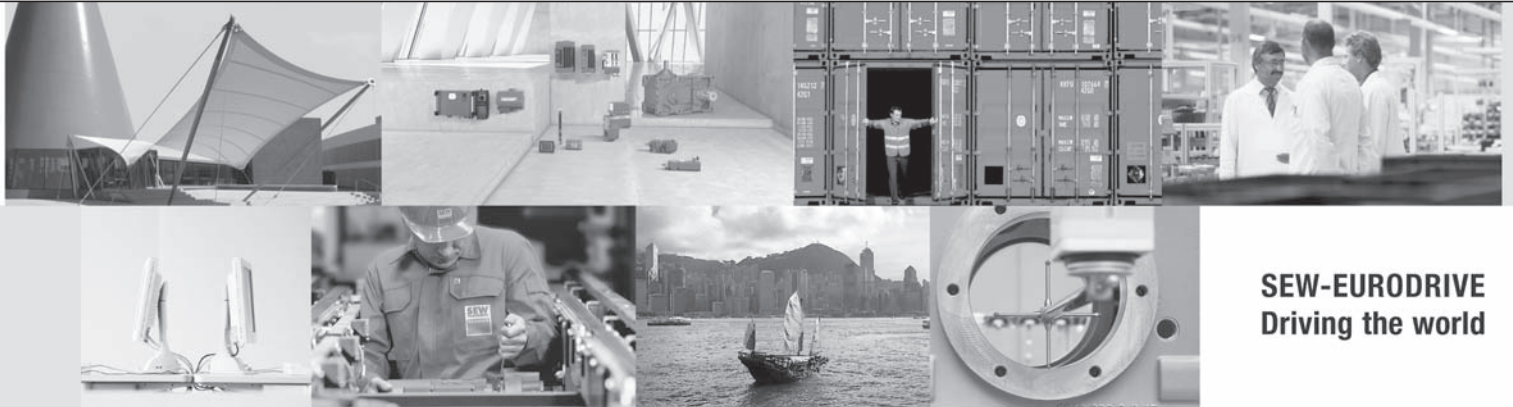

**SEW-EURODRIVE**  
Driving the world

**SEW**  
**EURODRIVE**

SEW-EURODRIVE GmbH & Co KG  
Ernst-Blickle-Str. 42  
76646 BRUCHSAL  
GERMANY  
Tel. +49 7251 75-0  
Fax +49 7251 75-1970  
sew@sew-eurodrive.com  
→ [www.sew-eurodrive.com](http://www.sew-eurodrive.com)