

ERH SERIES

The ERH series is a compact, robust cycloidal reducer designed for servo applications. This product features high reduction ratios in a compact form factor. Its key advantage is exceptional shock load capacity, which eliminates the need to oversize the reducer for that requirement. The dual pin housing of the ERH cycloidal provides the ability to adjust one wheel against the other, allowing us to reduce the output shaft backlash to less than 6 arc-minutes. Rolling contact contributes to minimal friction and high efficiency. Torque transmission elements experience compression—they do not shear. The long output shaft bearing span provides solid overhung load capability.

The ERH is ideal for applications operating in heavier industrial environments, but requiring servomotor mounting and good accuracy. Its compactness offers advantages against helical gearing, which requires additional stages to achieve higher reduction ratios. Its high efficiency against worm gears allows our customers to downsize and still enjoy larger output power. The end result is longer service life and tremendous energy saving.

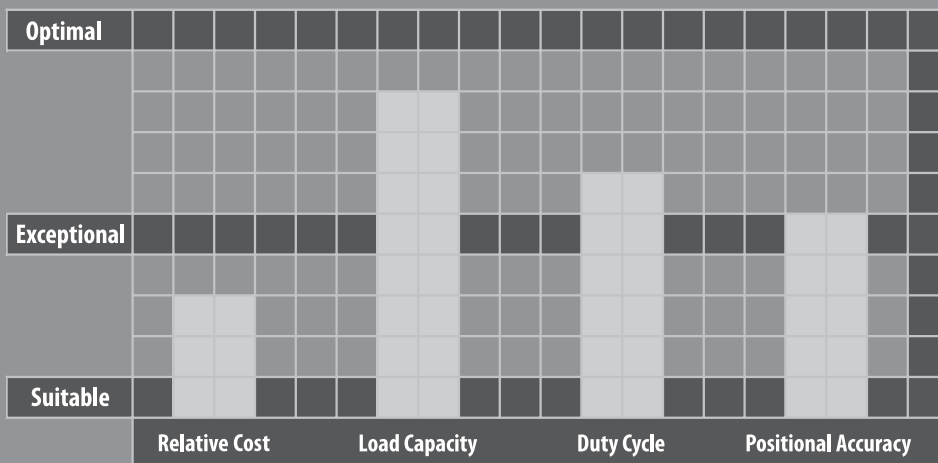

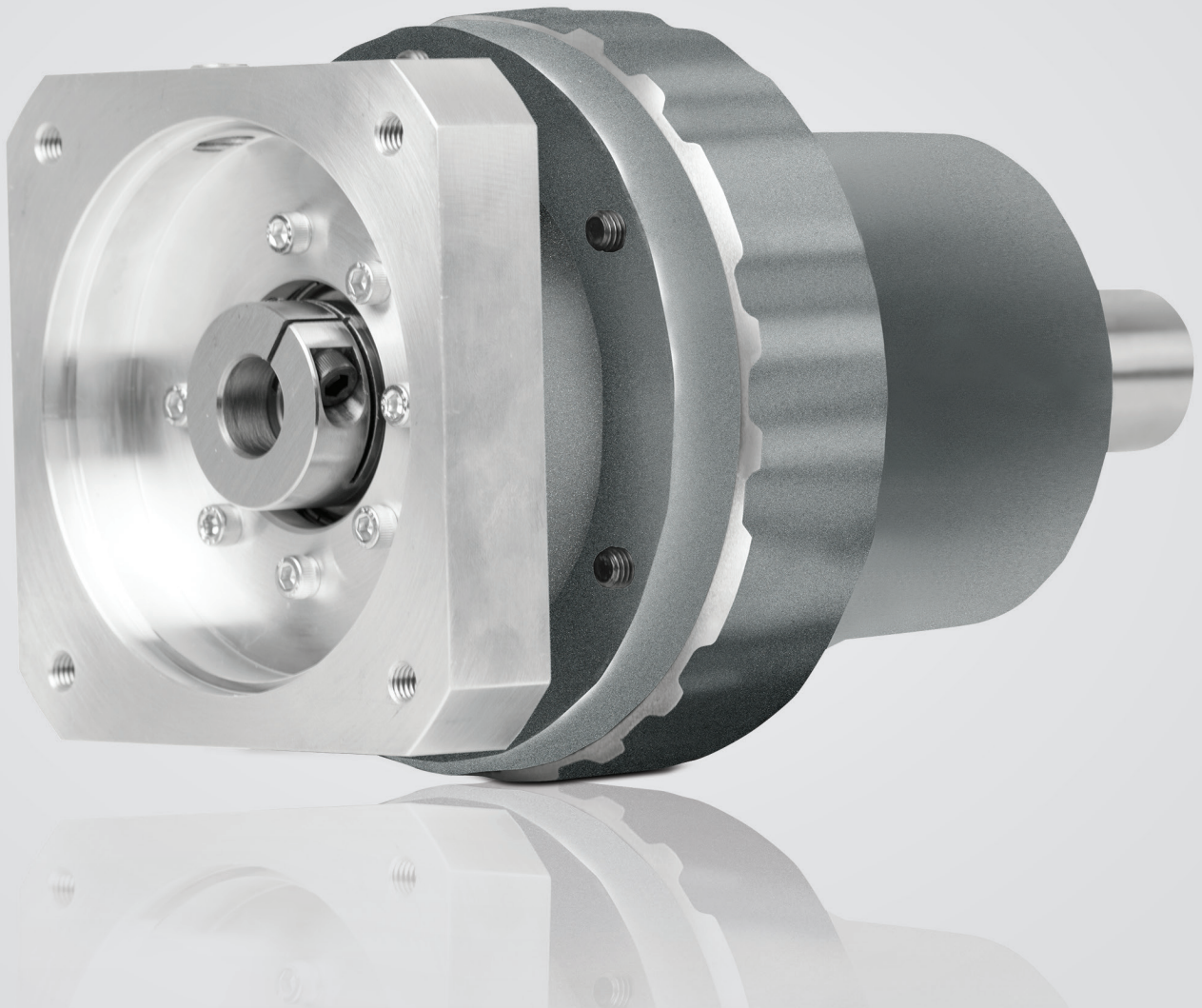

ERH SERIES

- High efficiency cycloidal reducer design
- Exceptional shock load capacity
- Various mounting options: Base, Flange, Ring, Hollow
- Reduction ratios up to 71:1 offered in a single stage
- Assembled in the USA

ERH SERIES Cycloidal Reducer

ERH Series Features

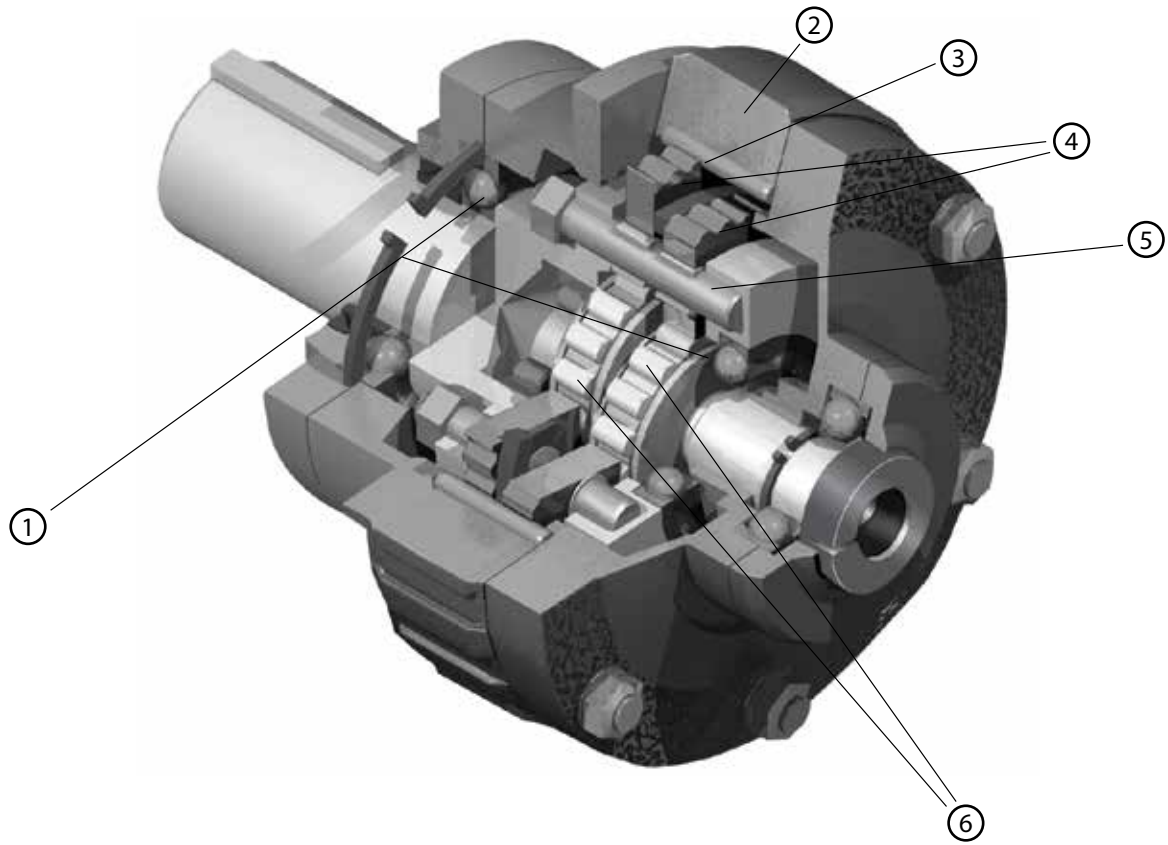

- ① Output shaft bearings
- ② Internal pin housing
- ③ Internal pins
- ④ Wheels
- ⑤ Carrier pins
- ⑥ Eccentric roller bearings

ERH Series Model Code

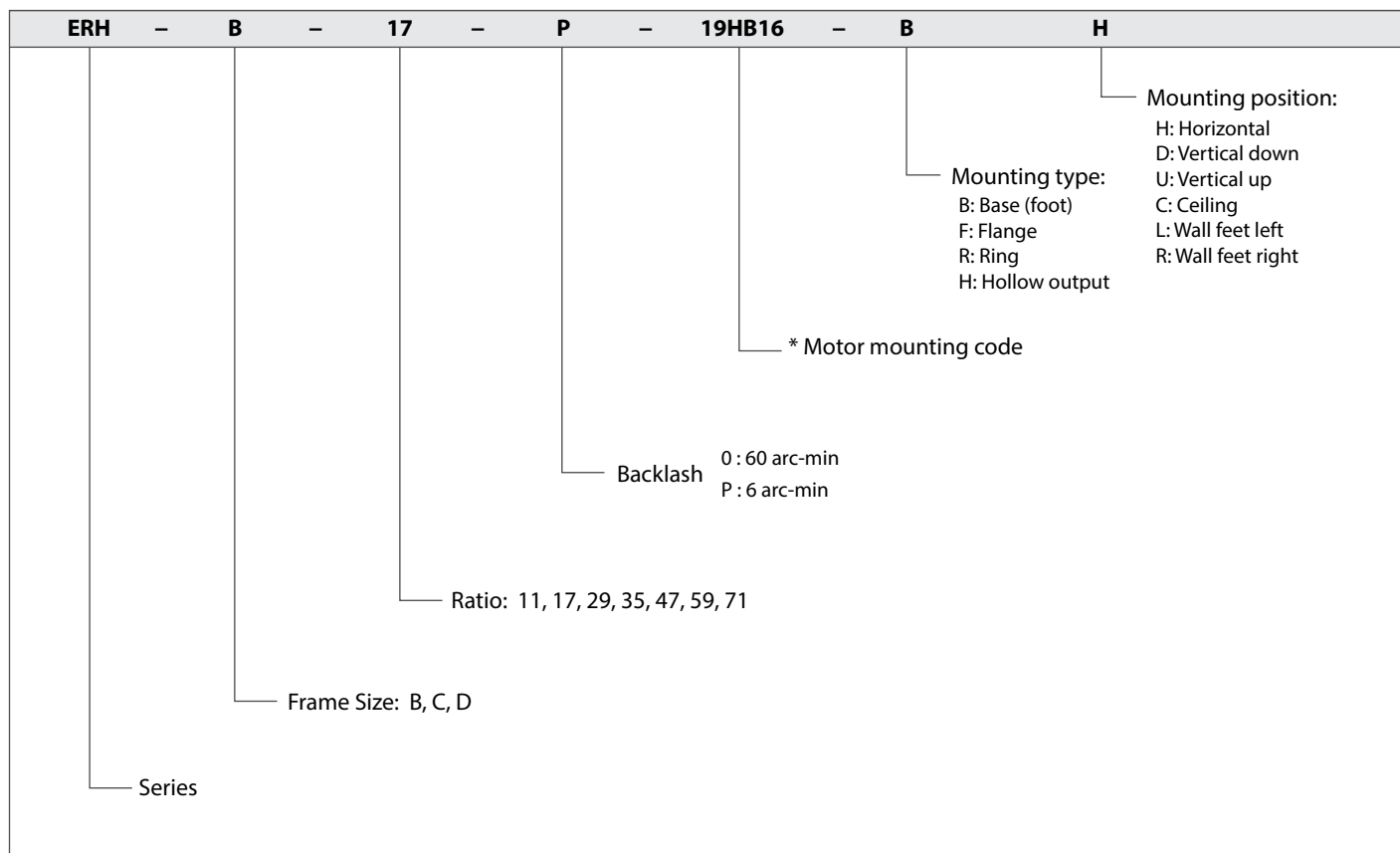

* Please contact us to assign mounting code for your motor.

ERH SERIES Cycloidal Reducer

ERH B Specifications

Frame Size	B										
Stage	Single Stage										
Ratio	Units	Note	11	17	29	35	47	59	71		
Nominal Output Torque	[Nm]	*1	80	87	105	101	107	105	102		
Maximum Acceleration Torque	[Nm]	*2	120	131	158	152	161	158	153		
Emergency Stop Torque	[Nm]	*3	200	218	263	251	267	261	254		
Nominal Output Torque (Precision)	[Nm]	*1	60	75	79	75	78	80	76		
Maximum Acceleration Torque (Precision)	[Nm]	*2	90	113	118	113	117	120	114		
Emergency Stop Torque (Precision)	[Nm]	*3	150	188	197	189	196	200	190		
Nominal Input Speed	[rpm]	*4	3000								
Maximum Input Speed	[rpm]	*5	4000								
No Load Running Torque	[Nm]	*6	0.4								
Permitted Radial Load	[N]	*7	4150	4750	5650	5690	5690	5690	5690		
Permitted Axial Load	[N]	*8	2070	2380	2820	2840	2840	2840	2840		
Maximum Radial Load	[N]	*9	5690								
Maximum Axial Load	[N]	*10	2840								
Moment of Inertia ($\leq \emptyset 19$)	[kgcm ²]	--	0.705	0.958	0.916	0.916	0.916	0.916	0.916		
Efficiency	[%]	*11	90								
Torsional Rigidity	[Nm/arcmin]	*12	3.0	4.7	5.0	5.4	5.4	5.4	5.4		
Backlash (Standard)	[Arc-min]	--	≤ 60								
Backlash (Precision)	[Arc-min]	--	≤ 6								
Noise Level	[dB]	*13	≤ 71								
Protection Class	--	*14	IP41 (IP65)								
Ambient Temperature	[°C]	--	0-40								
Permitted Housing Temperature	[°C]	--	90								
Lubrication	--	--	Oil (≥ 2000 rpm & Precision) / Grease (< 2000 rpm)								
Weight	[kg]	*15	19								

*1) At nominal input speed, service life is 10,000 hours

*2) The maximum torque when starting or stopping operation

*3) The maximum torque allowed under a stress situation (Permitted 1,000 times during service life)

*4) The average input speed

*5) The maximum intermittent input speed

*6) Torque at no load applied to the input shaft at nominal input speed

*7) At this load and nominal input speed, service life will be 20,000 hours. (The radial load applied to the output side shaft center)

*8) At this load and nominal input speed, service life will be 20,000 hours. (The axial load applied to the output side bearing)

*9) The maximum radial load that the gearbox can accept

*10) The maximum axial load that the gearbox can accept

*11) The efficiency at the nominal output torque rating

*12) This does not include lost motion

*13) Contact NIDEC-SHIMPO for the testing conditions and environment

*14) IP65 (wash-down) is available as an option. Contact NIDEC-SHIMPO for more details

*15) The weight may vary slightly between models

ERH B Dimensions

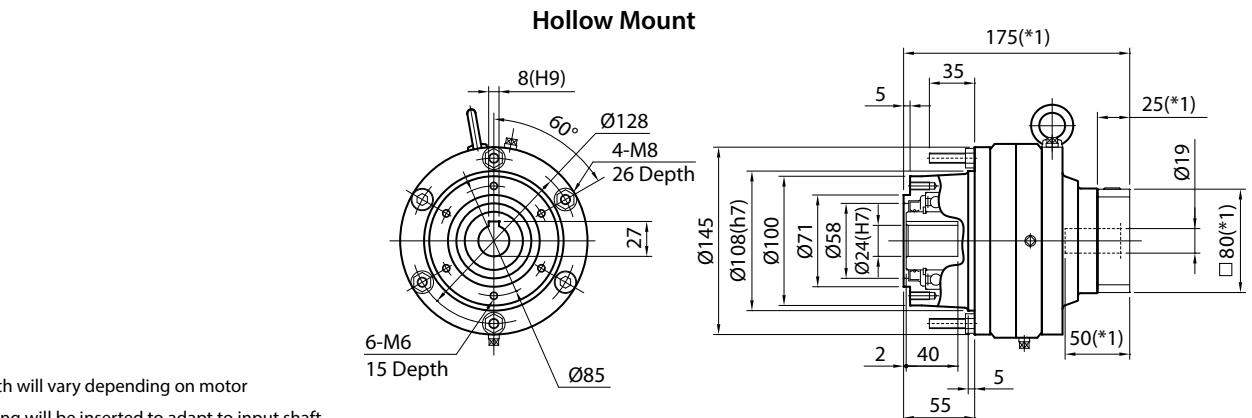
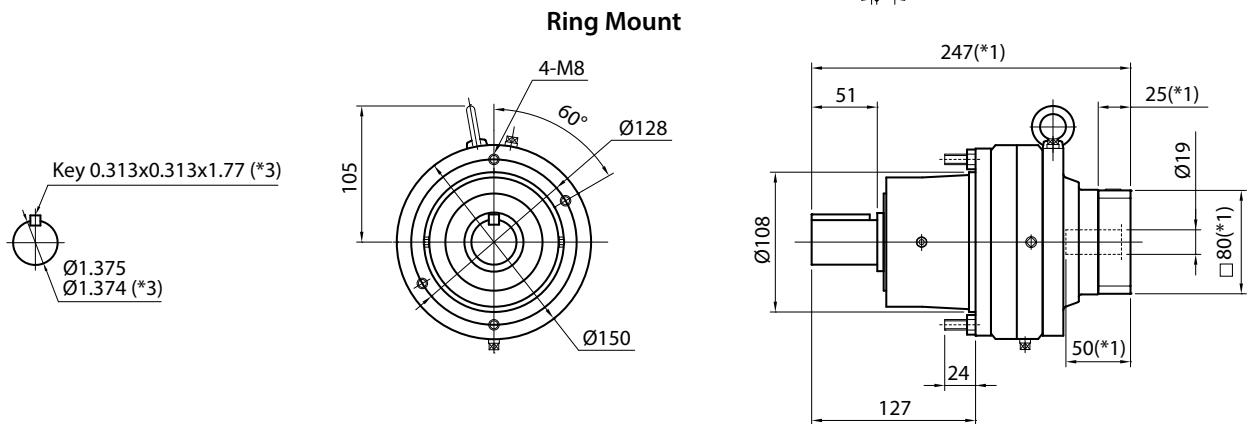
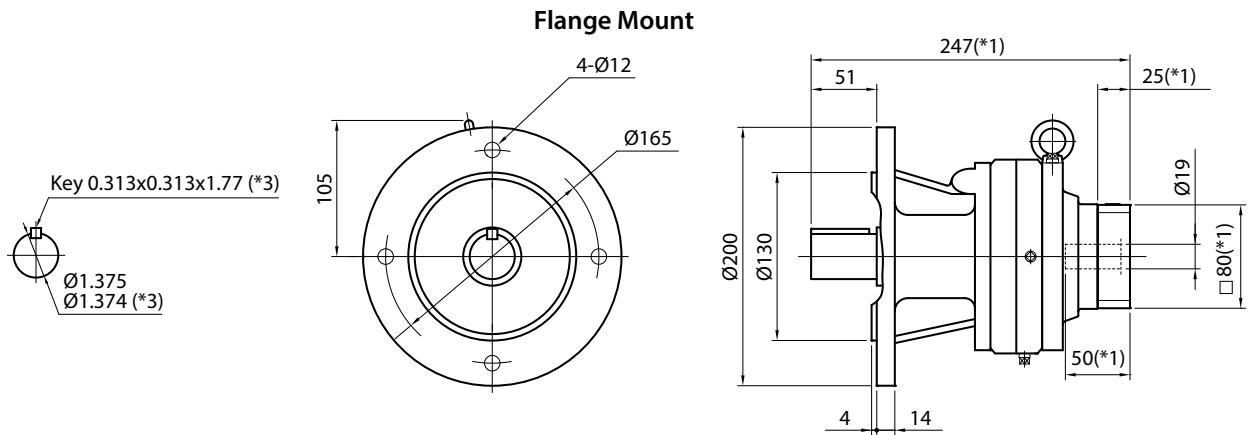
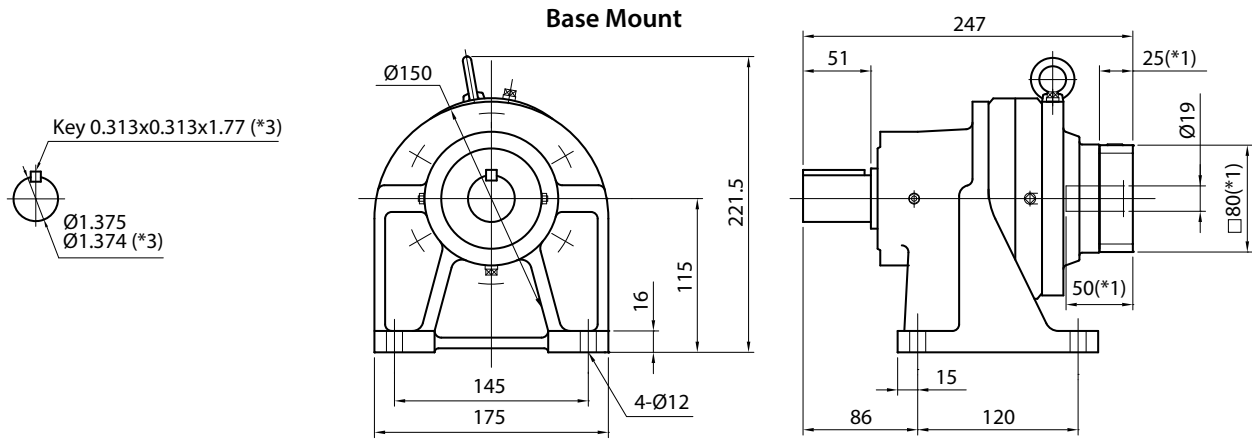

- *1) Length will vary depending on motor
- *2) Bushing will be inserted to adapt to input shaft
- *3) Unit is in inches of measurement

ERH SERIES Cycloidal Reducer

ERH C Specifications

Frame Size	C										
Stage	Single Stage										
Ratio	Units	Note	11	17	29	35	47	59	71		
Nominal Output Torque	[Nm]	*1	173	233	249	276	286	286	285		
Maximum Acceleration Torque	[Nm]	*2	260	350	374	414	429	429	428		
Emergency Stop Torque	[Nm]	*3	434	583	622	690	715	715	713		
Nominal Output Torque (Precision)	[Nm]	*1	122	175	187	207	214	214	214		
Maximum Acceleration Torque (Precision)	[Nm]	*2	183	263	281	311	321	321	321		
Emergency Stop Torque (Precision)	[Nm]	*3	306	437	467	517	536	536	535		
Nominal Input Speed	[rpm]	*4	3000								
Maximum Input Speed	[rpm]	*5	4000								
No Load Running Torque	[Nm]	*6	0.9								
Permitted Radial Load	[N]	*7	6270	7690	8670	9380	10140	10850	11560		
Permitted Axial Load	[N]	*8	3130	3840	4330	4690	5070	5420	5780		
Maximum Radial Load	[N]	*9	12270								
Maximum Axial Load	[N]	*10	6130								
Moment of Inertia ($\leq \varnothing 28$)	[kgcm ²]	--	3.733	4.027	4.786	4.744	4.701	4.701	4.701		
Efficiency	[%]	*11	90								
Torsional Rigidity	[Nm/arcmin]	*12	6.2	11.2	11.9	12.6	12.6	12.6	12.6		
Backlash (Standard)	[Arc-min]	--	≤ 60								
Backlash (Precision)	[Arc-min]	--	≤ 6								
Noise Level	[dB]	*13	≤ 75								
Protection Class	--	*14	IP41 (IP65)								
Ambient Temperature	[°C]	--	0-40								
Permitted Housing Temperature	[°C]	--	90								
Lubrication	--	--	Oil (\Rightarrow 2000rpm & Precision) / Grease ($<$ 2000rpm)								
Weight	[kg]	*15	43								

*1) At nominal input speed, service life is 10,000 hours

*2) The maximum torque when starting or stopping operation

*3) The maximum torque allowed under a stress situation (Permitted 1,000 times during service life)

*4) The average input speed

*5) The maximum intermittent input speed

*6) Torque at no load applied to the input shaft at nominal input speed

*7) At this load and nominal input speed, service life will be 20,000 hours. (The radial load applied to the output side shaft center)

*8) At this load and nominal input speed, service life will be 20,000 hours. (The axial load applied to the output side bearing)

*9) The maximum radial load that the gearbox can accept

*10) The maximum axial load that the gearbox can accept

*11) The efficiency at the nominal output torque rating

*12) This does not include lost motion

*13) Contact NIDEC-SHIMPO for the testing conditions and environment

*14) IP65 (wash-down) is available as an option. Contact NIDEC-SHIMPO for more details

*15) The weight may vary slightly between models

ERH C Dimensions

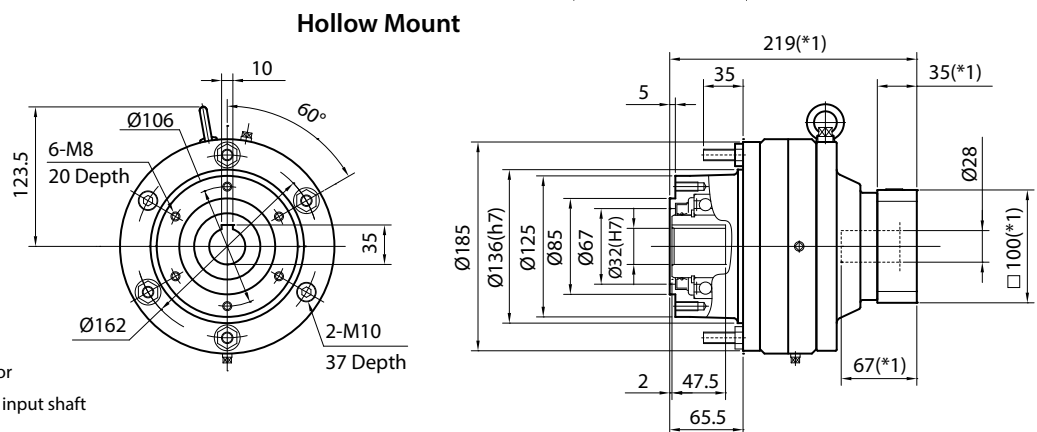
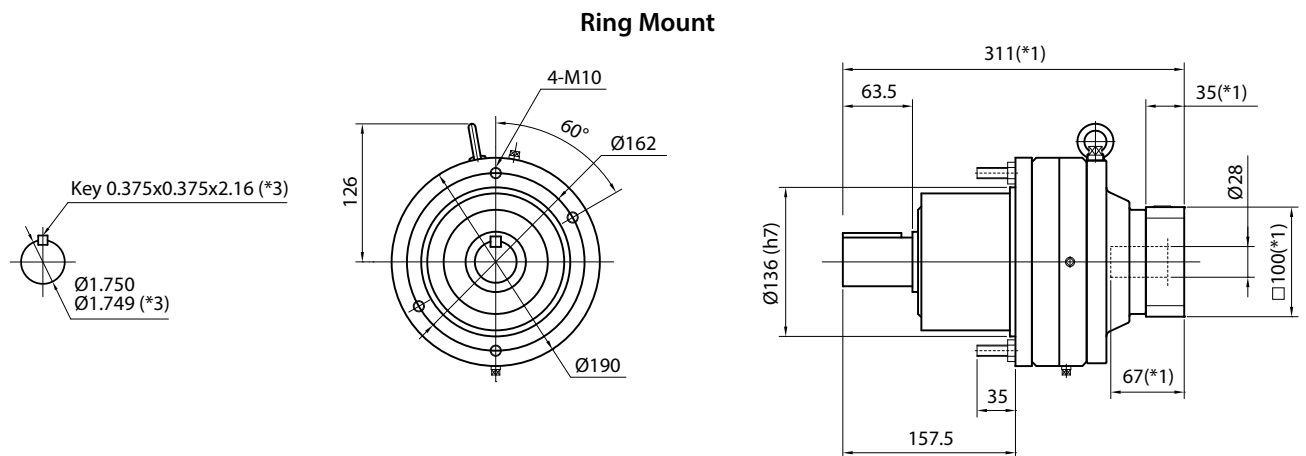
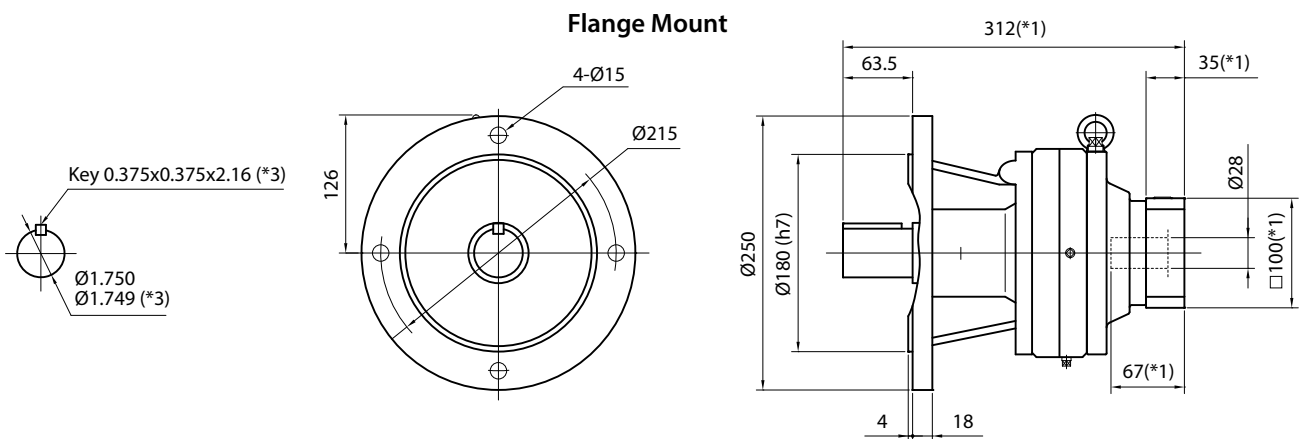
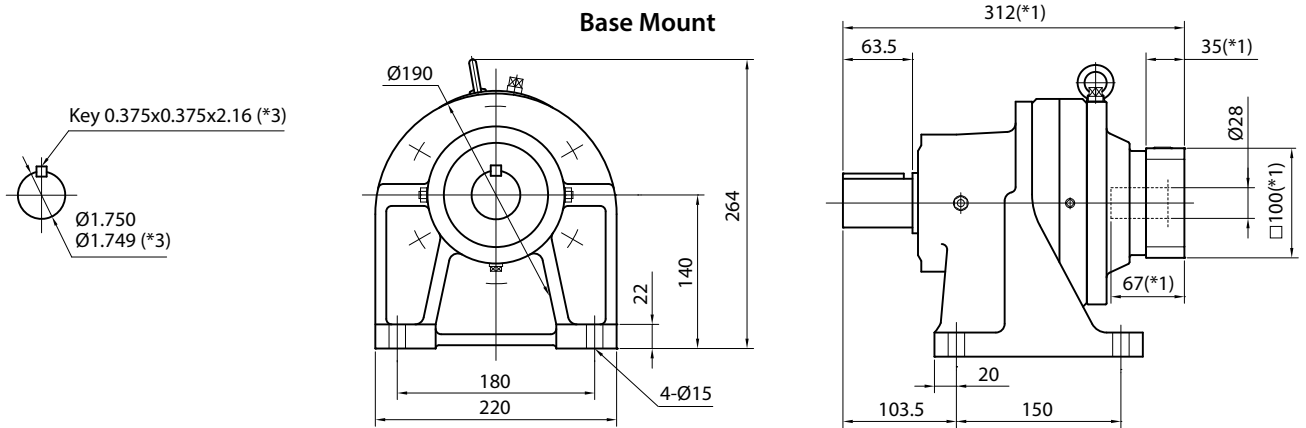

- *1) Length will vary depending on motor
- *2) Bushing will be inserted to adapt to input shaft
- *3) Unit is in inches of measurement

ERH SERIES Cycloidal Reducer

ERH D Specifications

Frame Size	D										
Stage	Single Stage										
Ratio	Units	Note	11	17	29	35	47	59	71		
Nominal Output Torque	[Nm]	*1	383	495	533	570	633	609	582		
Maximum Acceleration Torque	[Nm]	*2	575	743	800	855	950	914	873		
Emergency Stop Torque	[Nm]	*3	957	1,240	1,330	1,420	1,580	1,520	1,460		
Nominal Output Torque (Precision)	[Nm]	*1	287	349	376	402	447	430	411		
Maximum Acceleration Torque (Precision)	[Nm]	*2	431	524	564	603	671	645	617		
Emergency Stop Torque (Precision)	[Nm]	*3	718	872	940	1,010	1,120	1,070	1,030		
Nominal Input Speed	[rpm]	*4	3000								
Maximum Input Speed	[rpm]	*5	4000								
No Load Running Torque	[Nm]	*6	1.9								
Permitted Radial Load	[N]	*7	11960	13740	15920	16630	18060	20240	20950		
Permitted Axial Load	[N]	*8	5980	6870	7960	8310	9030	10120	10470		
Maximum Radial Load	[N]	*9	22420								
Maximum Axial Load	[N]	*10	11210								
Moment of Inertia ($\leq \varnothing 28$)	[kgcm ²]	--	5.08	7.21	7.88	7.71	7.71	7.71	7.54		
Moment of Inertia ($\leq \varnothing 38$)	[kgcm ²]	--	7.75	11.00	12.01	11.75	11.75	11.75	11.50		
Efficiency	[%]	*11	90								
Torsional Rigidity	[Nm/arcmin]	*12	17.8	23.0	25.2	27.4	27.4	27.4	27.4		
Backlash (Standard)	[Arc-min]	--	≤ 60								
Backlash (Precision)	[Arc-min]	--	≤ 6								
Noise Level	[dB]	*13	≤ 78								
Protection Class	--	*14	IP41 (IP65)								
Ambient Temperature	[°C]	--	0-40								
Permitted Housing Temperature	[°C]	--	90								
Lubrication	--	--	Oil								
Weight	[kg]	*15	68								

*1) At nominal input speed, service life is 10,000 hours

*2) The maximum torque when starting or stopping operation

*3) The maximum torque allowed under a stress situation (Permitted 1,000 times during service life)

*4) The average input speed

*5) The maximum intermittent input speed

*6) Torque at no load applied to the input shaft at nominal input speed

*7) At this load and nominal input speed, service life will be 20,000 hours. (The radial load applied to the output side shaft center)

*8) At this load and nominal input speed, service life will be 20,000 hours. (The axial load applied to the output side bearing)

*9) The maximum radial load that the gearbox can accept

*10) The maximum axial load that the gearbox can accept

*11) The efficiency at the nominal output torque rating

*12) This does not include lost motion

*13) Contact NIDEC-SHIMPO for the testing conditions and environment

*14) IP65 (wash-down) is available as an option. Contact NIDEC-SHIMPO for more details

*15) The weight may vary slightly between models

ERH D Dimensions (Input Bore $\leq \varnothing 28$)

Base Mount

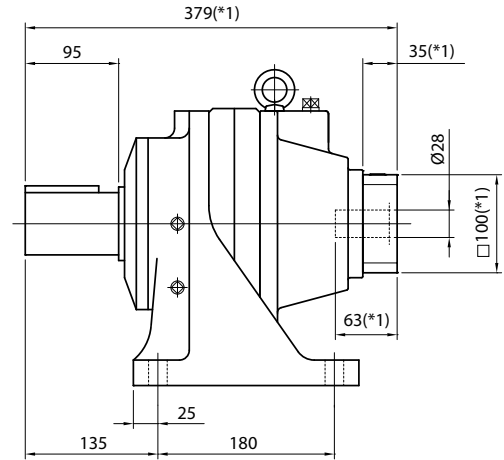
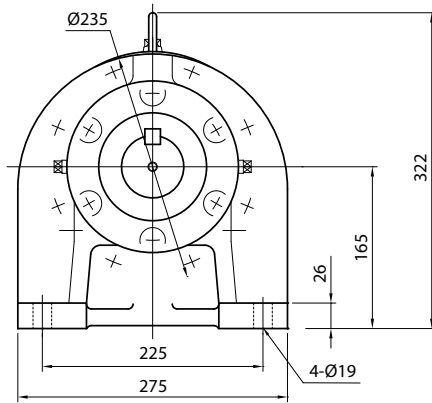
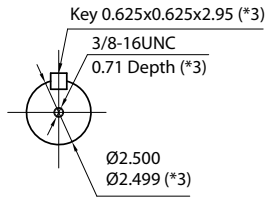

Flange Mount

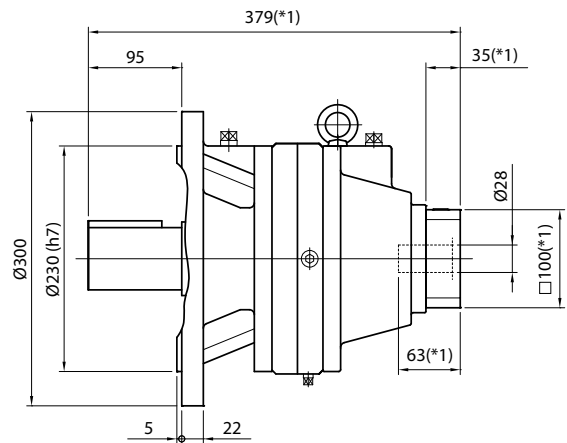
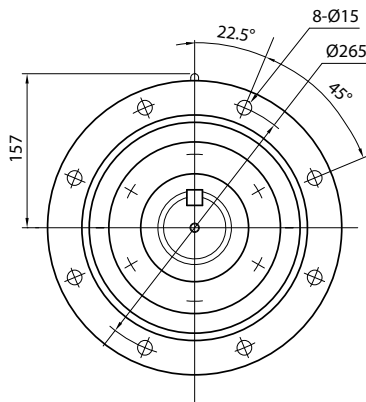
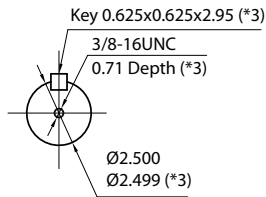

Ring Mount

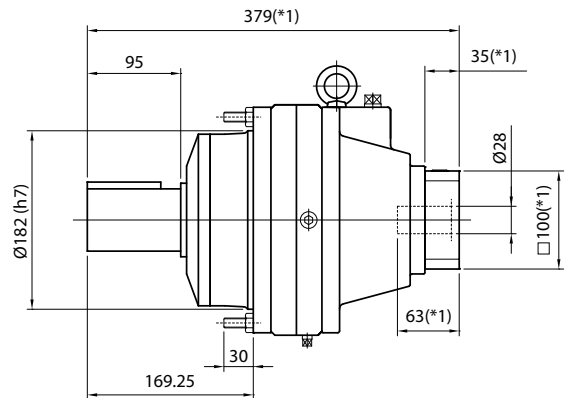
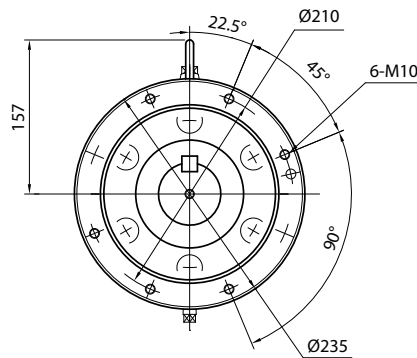
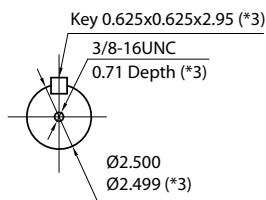

Hollow Mount

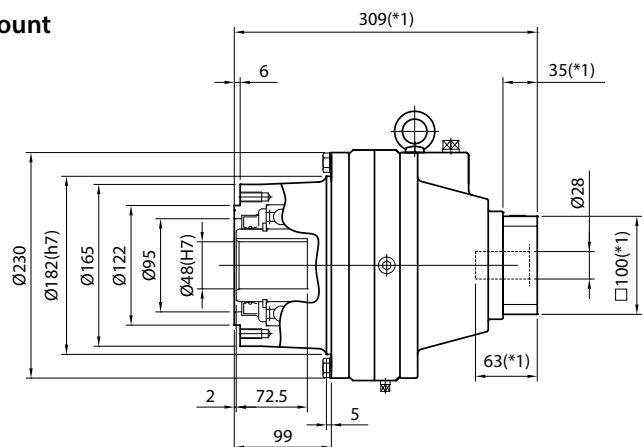
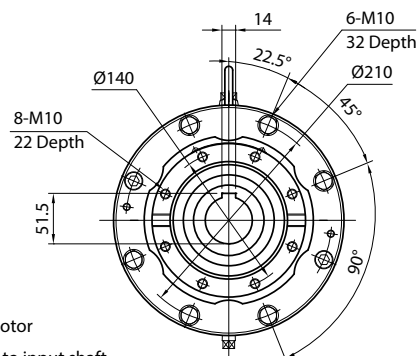

*1) Length will vary depending on motor

*2) Bushing will be inserted to adapt to input shaft

*3) Unit is in inches of measurement

ERH SERIES Cycloidal Reducer

ERH D Specifications

Frame Size	D										
Stage	Single Stage										
Ratio	Units	Note	11	17	29	35	47	59	71		
Nominal Output Torque	[Nm]	*1	383	495	533	570	633	609	582		
Maximum Acceleration Torque	[Nm]	*2	575	743	800	855	950	914	873		
Emergency Stop Torque	[Nm]	*3	957	1,240	1,330	1,420	1,580	1,520	1,460		
Nominal Output Torque (Precision)	[Nm]	*1	287	349	376	402	447	430	411		
Maximum Acceleration Torque (Precision)	[Nm]	*2	431	524	564	603	671	645	617		
Emergency Stop Torque (Precision)	[Nm]	*3	718	872	940	1,010	1,120	1,070	1,030		
Nominal Input Speed	[rpm]	*4	3000								
Maximum Input Speed	[rpm]	*5	4000								
No Load Running Torque	[Nm]	*6	1.9								
Permitted Radial Load	[N]	*7	11960	13740	15920	16630	18060	20240	20950		
Permitted Axial Load	[N]	*8	5980	6870	7960	8310	9030	10120	10470		
Maximum Radial Load	[N]	*9	22420								
Maximum Axial Load	[N]	*10	11210								
Moment of Inertia ($\leq \varnothing 28$)	[kgcm ²]	--	5.08	7.21	7.88	7.71	7.71	7.71	7.54		
Moment of Inertia ($\leq \varnothing 38$)	[kgcm ²]	--	7.75	11.00	12.01	11.75	11.75	11.75	11.50		
Efficiency	[%]	*11	90								
Torsional Rigidity	[Nm/arcmin]	*12	17.8	23.0	25.2	27.4	27.4	27.4	27.4		
Backlash (Standard)	[Arc-min]	--	≤ 60								
Backlash (Precision)	[Arc-min]	--	≤ 6								
Noise Level	[dB]	*13	≤ 78								
Protection Class	--	*14	IP41 (IP65)								
Ambient Temperature	[°C]	--	0-40								
Permitted Housing Temperature	[°C]	--	90								
Lubrication	--	--	Oil								
Weight	[kg]	*15	68								

*1) At nominal input speed, service life is 10,000 hours

*2) The maximum torque when starting or stopping operation

*3) The maximum torque allowed under a stress situation (Permitted 1,000 times during service life)

*4) The average input speed

*5) The maximum intermittent input speed

*6) Torque at no load applied to the input shaft at nominal input speed

*7) At this load and nominal input speed, service life will be 20,000 hours. (The radial load applied to the output side shaft center)

*8) At this load and nominal input speed, service life will be 20,000 hours. (The axial load applied to the output side bearing)

*9) The maximum radial load that the gearbox can accept

*10) The maximum axial load that the gearbox can accept

*11) The efficiency at the nominal output torque rating

*12) This does not include lost motion

*13) Contact NIDEC-SHIMPO for the testing conditions and environment

*14) IP65 (wash-down) is available as an option. Contact NIDEC-SHIMPO for more details

*15) The weight may vary slightly between models

ERH D Dimensions (Input Bore $\leq \varnothing 38$)

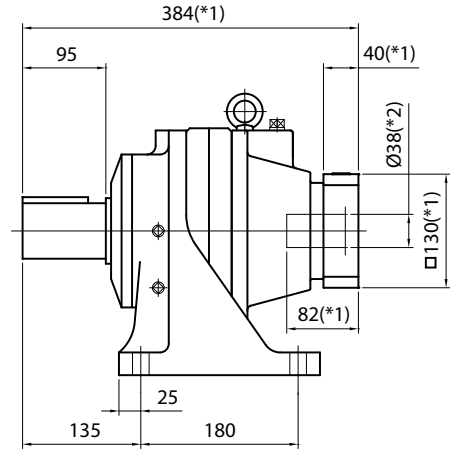
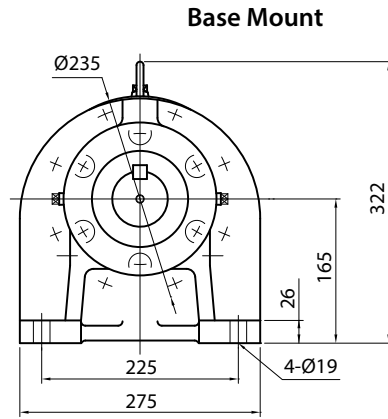
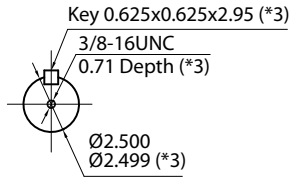

Flange Mount

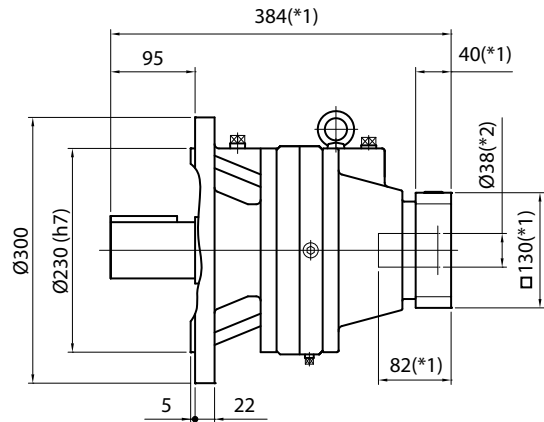
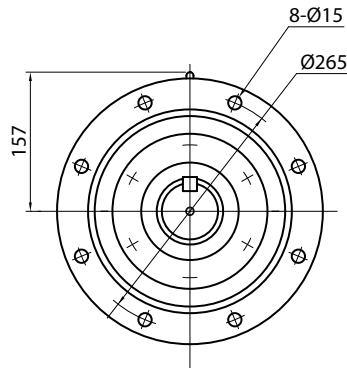
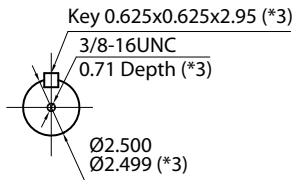

Ring Mount

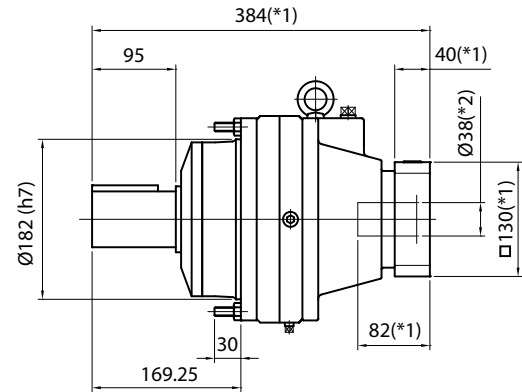
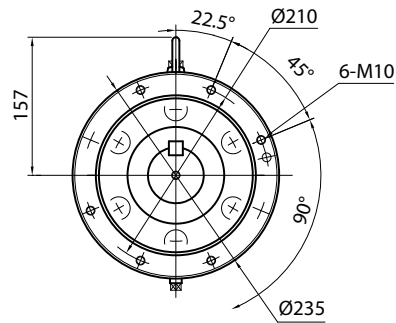
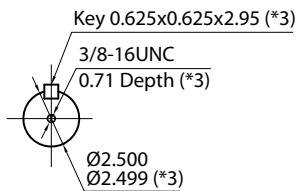

Hollow Mount

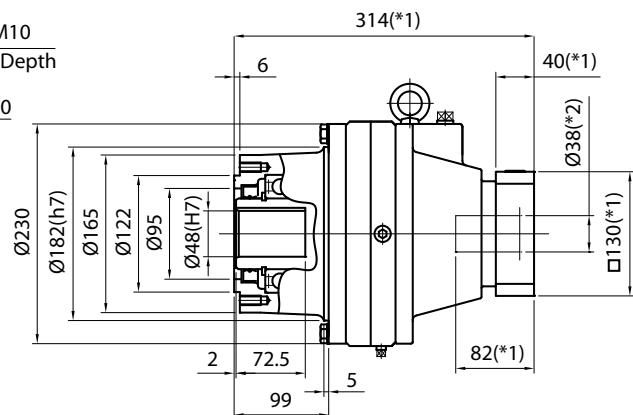
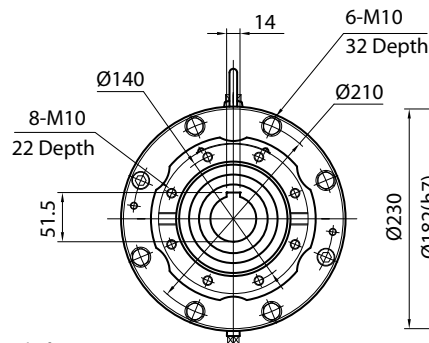

- *1) Length will vary depending on motor
- *2) Bushing will be inserted to adapt to input shaft
- *3) Unit is in inches of measurement